

## B.5 Mastrapport combi-hoekmasten

ZUID-WEST 380 KV OOST VERBINDINGEN

# Mastrapport combi-hoekmasten HB/c

TenneT TSO B.V.

Meridian doc.nr.: 002.678.00.0928552

Rapport nr.: 21-0816, Rev. 1

Datum:







Projectnaam: Zuid-West 380 kV Oost Verbindingen  
Rapport titel: Mastrapport combi-hoekmasten HB/c  
Klant: TenneT TSO B.V.,  
Contactpersoon klant: [Redacted]  
Datum uitgave: 2021-07-19  
Project nr.: 10124719  
Organisatie unit: TDT  
Meridian doc.nr.: 002.678.00.0928552  
Rapport nr.: 21-0816, Rev. 1

Energy Systems  
DNV Netherlands B.V.  
Utrechtseweg 310-B50  
6812 AR Arnhem  
  
Tel: 026 356 9111  
Handelsregister Arnhem 09006404

Geschreven door: Beoordeeld door: Goedgekeurd door:



Copyright © DNV 2021. All rights reserved. Unless otherwise agreed in writing: (i) This publication or parts thereof may not be copied, reproduced or transmitted in any form, or by any means, whether digitally or otherwise; (ii) The content of this publication shall be kept confidential by the customer; (iii) No third party may rely on its contents; and (iv) DNV undertakes no duty of care toward any third party. Reference to part of this publication which may lead to misinterpretation is prohibited.

DNV Distributie:

- Open
- Intern
- Commercieel vertrouwelijk
- Vertrouwelijk
- Geheim

\*Specificatie distributie: --

Trefwoorden:

[Trefwoorden]

Rev.	Datum	Reden van uitgave	Auteur	Beoordelaar	Goedkeuder
0	2021-05-26	Eerste uitgave	[Redacted]	[Redacted]	[Redacted]
1	2021-07-19	RFA-commentaar verwerkt	[Redacted]	[Redacted]	[Redacted]

## Inhoudsopgave

1	INLEIDING .....	1
2	UITGANGSPUNTEN EN RANDVOORWAARDEN .....	2
2.1	Normen	2
2.2	TenneT-specificaties	2
2.3	Eisenverificatie	2
2.4	Ontwerprapporten	2
2.5	Materialen	2
2.6	Software	3
3	MASTONTWERP .....	3
3.1	Mastbeelden	3
3.2	Uitgangspunten berekening	6
3.3	Mastenlijst	6
3.4	Geleiderbelastingen	6
3.5	Reacties op de fundering	7
3.6	Modellering	7
3.7	Overige controles	7
3.8	Mastgewicht	7
4	TOETSING .....	8
4.1	Resultaat PLS-TOWER	8
4.2	Toetsing overige onderdelen	10
Appendix A	Geleiderbelastingen	
Appendix B	Resultaten PLS	
Appendix C	Knikverkorters	
Appendix D	Blokdeuvels	
Appendix E	Liggers	
Appendix F	Sterkte-coördinatie	
Appendix G	Galloping	

## 1 INLEIDING

In het basisontwerp van de vakwerkmasten voor de verbinding RLL-TLB380 in het project Zuid-West 380 kV-Oost zijn voor het vaststellen van de haalbaarheid constructieve berekeningen uitgevoerd aan de masten en fundaties. In de Definitief Ontwerpfase, moeten berekeningen verder worden uitgewerkt om te kunnen dienen voor de benodigde vergunningsdocumentatie, voor de aanbesteding en als voorbereiding voor de uitvoeringsfase. Het DO omvat het ontwerp van de mastconstructies, de fundaties en de opstijpunten in de verbinding.

Deze rapportage bevat de resultaten van de toetsing van alle masttypen binnen de groep van combi-hoekmasten type HB, een masttype geschikt voor 2 circuits 150 kV en 380 kV en geschikt voor lijnhoeken van 160° tot 140°. Het ontwerp van de combi-hoekmasten HB+0/c en HB+6/c is zodanig dat de "mastkop" gedeeld wordt binnen de groep van de combi-HB-hoekmasten, alleen de hoogte van het onderstuk verschilt

In deze rapportage is de toetsing van de mastkop van de combi-HB-hoekmasten en de toetsing van alle onderstukken van de verschillende typen opgenomen. De toetsing bestaat uit controle van:

- de profielen en boutverbindingen onderdeel van de hoofd draagconstructie
- de knikverkorters
- de liggers voor de isolator kettingen
- de verbinding met de fundatie via blokdeuvels
- aanvullende controle op sterkte-coördinatie

Buiten de scope van dit DO-rapport valt de controle van de schetsplaten en overige verbinding details in de constructie. Dit moet in de UO-fase worden uitgewerkt. Ook de voorzieningen voor de high-step rail en bordessen vallen onder uitwerking in UO-fase.

In hoofdstuk 2 zijn de uitgangspunten en randvoorwaarden vanuit de van toepassing zijnde normen en TenneT-specificaties opgenomen. Hoofdstuk 3 beschrijft de gevolgde aanpak van de berekening. In hoofdstuk 4 is de toetsing opgenomen.

## 2 UITGANGSPUNTEN EN RANDVOORWAARDEN

### 2.1 Normen

Er is gebruik gemaakt van de normen volgens Tabel 1.

**Tabel 1 Gebruikgemaakte normen, voorschriften en richtlijnen**

Norm	Titel
NEN-EN 50341-1:2013	“Overhead electrical lines exceeding AC 1 kV - Part 1: General requirements – Common”
NEN-EN 50341-2-15:2019	“Overhead electrical lines exceeding AC 1 kV Part 2 National Normative Aspects (NNA) for THE NETHERLANDS”
NEN-EN 1990+A1+A1/C2:2019/NB:2019nl	“Grondslagen van het ontwerp”
NEN-EN 1991-1-4+A1+C2:2011/NB:2019+C1:2020	“Deel 1-4: Windbelasting op constructies”
NEN-EN 1992-1-1+C2:2011/NB:2016+A1:2020	“Eurocode 2: Ontwerp en berekening van betonconstructies, deel 1-1: algemene regels en regels voor gebouwen”
NEN-EN 1993-1-1+C2+A1:2016 nl	“Eurocode 3: Ontwerp en berekening van staalconstructies, deel 1-1: algemene regels en regels voor gebouwen”
NEN-EN 1993-3-1:2007/NB:2011 nl	“Deel 3-1: Torens, masten en schoorstenen - Torens en masten”
NEN-EN 1993-1-8+C2:2011/NB:2011 nl	“Ontwerp en berekening van staalconstructies, deel 1-8: ontwerp en berekening van verbindingen”

### 2.2 TenneT-specificaties

In Tabel 2 zijn de documenten opgenomen die relevant zijn voor de berekeningen en toetsingen die binnen dit project in de mastrapportage uitgevoerd zullen worden.

**Tabel 2 Relevante documenten t.b.v. mechanische rapportages**

Nummer	Onderwerp
PVE.05.000 v3.2	PvE Lijnen
sPVE.05.001	sPvE Lijnen
SPE.05.346 v1.3	Algemene specificatie stalen masten

### 2.3 Eisenverificatie

Voor de eisenverificatie wordt verwezen naar het rapport “Verificatierapport eisen DO Moldau”, DNV GL rapport 21-0451, Meridiannummer 002.678.00 0910757.

### 2.4 Ontwerpprojecten

Voor de achtergrond van het ontwerp wordt verwezen naar het uitgangspuntenrapport “Uitgangspunten definitief ontwerp Moldaumast”, DNV GL rapport 21-0036, Meridiannummer 002.678.00 0876917.

### 2.5 Materialen

Voor het ontwerp van de mastconstructies en fundaties wordt uitgegaan van de eigenschappen volgens Tabel 3.

**Tabel 3 Materialen aangepaste constructie**

Staalsoort	S355J0 (t≤16 mm) S355J2 (16<t≤40 mm)
Boutkwaliteit	8.8 gerolde draad
Betonkwaliteit	C30/37
Wapeningsstaal	B500

Voor de constructie geldt conform TenneT-specificatie:

- Toe te passen bouten: M16/M20/M24;
- Voor hoekstaal is de minimale afmeting L50x5 mm;
- Minimale plaatdikte 6 mm.

Mocht het noodzakelijk zijn M30 toe te passen, bij grote plaatdiktes is dit als afwijking door TenneT toegestaan.

## 2.6 Software

De gebruikte software wordt benoemd in Tabel 4.

**Tabel 4 Toegepaste software**

Software		Versie
Mastontwerp	PLS-CADD	16.65
Mastberekeningen	PLS-TOWER	16.65
Constructieve analyse	AxisVM	X5 R4h

## 3 MASTONTWERP

### 3.1 Mastbeelden

In dit hoofdstuk worden de mastbeelden weergegeven met de belangrijkste maatvoering, voor volledige tekeningen van de masttypen wordt verwezen naar onderstaande tekeningen:

- Mastbeeldentekening Hoekmasten, Meridiannummer 002.678.00 0890099
- Overzichtstekening HB+0/c, Meridiannummer 002.678.00 0927482
- Overzichtstekening HB+6/c, Meridiannummer 002.678.00 0927483

Masttype HB/c is een combimast voor twee circuits 380 kV en twee circuits 150kV. De belastingen grijpen als trekkrachten aan via de afspankettingen. Onder de traverse bevinden zich verticale post-isolatoren die de bretellebogen fixeren.

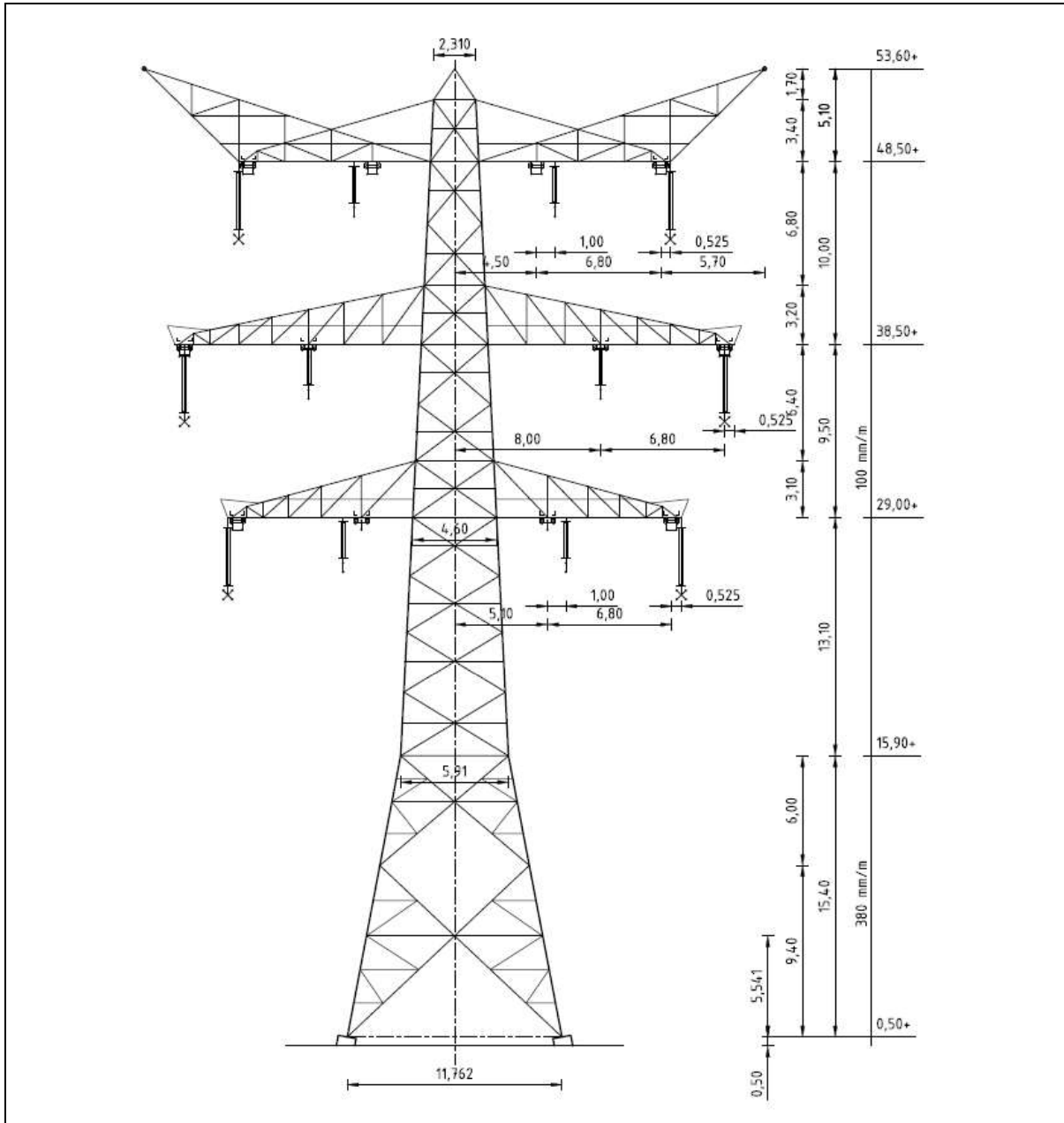

Figuur 1 Mastbeeld masttype HB+0/c

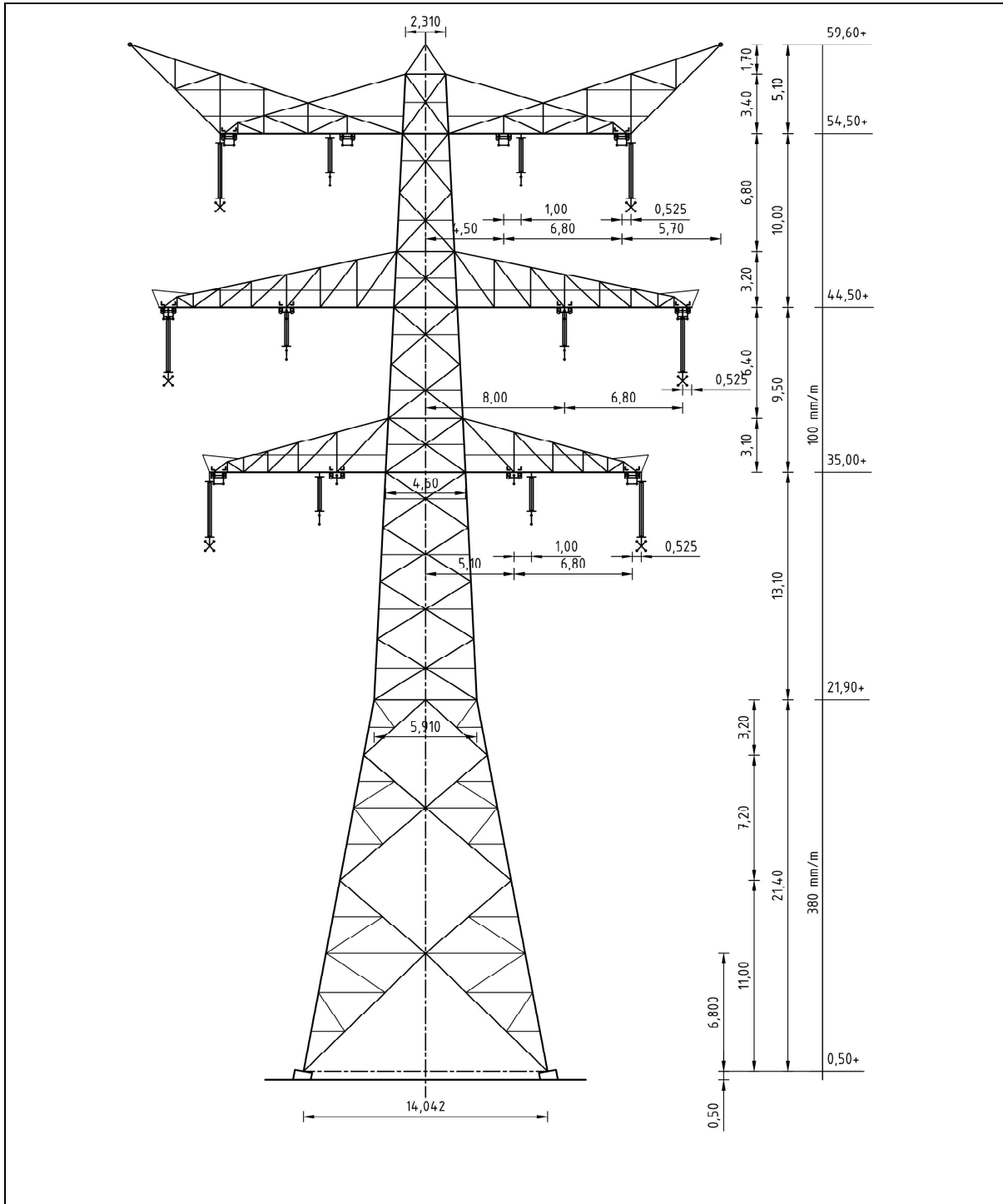

Figuur 2 Mastbeeld masttype HB+6/c

### 3.2 Uitgangspunten berekening

De uitgangspunten volgens Tabel 5 zijn van toepassing.

**Tabel 5 Uitgangspunten**

Norm	NEN-EN50341-2-15:2019
Gevolgklasse initieel	CC2
Betrouwbaarheidsniveau	Nieuwbouw
Referentieperiode	50 jaar
Windgebied	III
Windsnelheid (m/s)	24,5
Terreincategorie	II
Reductiefactor $c_{dir}$	1,00
IJsgebied fasegeleider	B
IJsgebied bliksemgeleider	A

### 3.3 Mastenlijst

De mastenlijst is gebaseerd op de “staking table” van het DO-uitgangspuntenrapport en benaamd als “VKA 1.1 Concept 20201112 1037-1044\_1086-1094\_1099-1105\_1192-1204.xlsx”. De mastenlijst is vanwege lopende traceringsvraagstukken aan verandering onderhevig en is derhalve indicatief.

In Tabel 6 tot en met Tabel 7 zijn alle masten in het tracé van het type HB+0/c en HB+6/c opgenomen. De mast met grootste wind span is vetgedrukt aangegeven. Het masttype zal niet met deze wind en weight span worden berekend maar met generieke wind en weight span, zie uitgangspuntenrapport.

**Tabel 6 Mastenlijst HB+0/c**

Mast-nummer	Masttype	Lijnhoek (°)	Wind span (m)	Weight span (m)	Hoogteverschil ba+ah (m)	Hoogteverschil back (m)	Hoogteverschil ahead (m)
1027	HB+0_c	150,8	316,1	334,1	3,0	3,3	-0,3
1037	HB+0_c	143,3	359,2	338,1	-4,6	-4,7	0,1
1118	HB+0_c	158,5	365,5	326,6	-9,1	-12,0	2,9
1177	HB+0_c	155,5	384,4	367,8	-3,6	-0,3	-3,3
<b>1184</b>	HB+0_c	140,1	301,0	270,0	-5,1	-0,4	-4,7
1192	HB+0_c	145,8	374,4	341,7	-6,5	0,0	-6,6

**Tabel 7 Mastenlijst HB+6/c**

Mast-nummer	Masttype	Lijnhoek (°)	Wind span (m)	Weight span (m)	Hoogteverschil ba+ah (m)	Hoogteverschil back (m)	Hoogteverschil ahead (m)
<b>1079</b>	HB+6_c	150,3	325,4	324,8	-0,2	-0,4	0,2

### 3.4 Geleiderbelastingen

De berekening is uitgevoerd met het geleiderbelastingprogramma van DNV GL. De belastingen op de mastconstructie zijn bepaald op basis van de modellering in PLS-TOWER (staafoppervlaktes). Voor de toeslagen op eigen gewicht en windoppervlakte wordt verwezen naar het uitgangspuntenrapport. In Appendix A zijn de resultaten van de geleiderbelastingen samengevat.



### 3.5 Reacties op de fundering

De oplegreacties op de fundering worden ontleend aan de uitvoer van het geleiderbelastingenprogramma. Zie Appendix A.

### 3.6 Modelling

Op basis van de ontwerptekeningen is de mast in PLS-TOWER ingevoerd. De toetsing wordt per staafgroep uitgevoerd. De hoofdelementen zijn gemodelleerd, niet-dragende profielen als knikverkorters zijn weggelaten, deze worden separaat getoetst. De profielen zijn in PLS-TOWER inclusief de boutverbindingen ingevoerd en getoetst, de controle van de schetsplaten en andere detailverbindingen valt buiten de scope.

De geleiderbelastingen vanuit het geleiderbelastingenprogramma zijn als invoer voor de belastingen gebruikt.

De gewichts- en windbelasting op de mastconstructie wordt door PLS-TOWER automatisch bepaald. Via toeslagfactoren wordt de invloed van niet gemodelleerde elementen als knikverkorters, bordesconstructies en klimvoorzieningen meegenomen. Voor schetsplaten, zinklaag en bouten is een aanvullende toeslag op het gewicht van 20% toeslag gerekend.

Diagonalen in voor- en achtervlak respectievelijk de twee zijvlakken zijn samengenomen in een groep.

### 3.7 Overige controles

In PLS-TOWER zijn niet alle elementen getoetst. Knikverkortersprofielen en overige profielen voor beloopbaarheid worden separaat getoetst. In Appendix C is dit opgenomen. De verbinding met de fundatie bestaat uit ingestorte profielen voorzien van blokdeuvels. Dit is in Appendix D opgenomen. De liggers van isolatorkettingen vereisen een aanvullende controle op buiging. De toetsing is uitgevoerd met de software AxisVM en is beschreven in Appendix E. Appendix F omvat de toetsing op sterkte-coördinatie. Voor hoekmasten moet een toetsing op vermoeiing worden uitgevoerd voor galloping. Dit is in Appendix G opgenomen.

De mastranden uitgevoerd als XEA-profielen worden separaat op torsieknik gecontroleerd. Dit is in Appendix B opgenomen. De berekende capaciteit die lager is dan de capaciteit voor buigingsknik is in PLS-TOWER via aangepaste buckling-ratio ingevoerd.

### 3.8 Mastgewicht

Het totale mastgewicht per masttype is met de uitgangspunten van paragraaf 3.6 bepaald op:

- Masttype HB+0/c -> 101,7 ton;
- Masttype HB+6/c -> 116,2 ton

## 4 TOETSING

### 4.1 Resultaat PLS-TOWER

Het resultaat van de toetsing met PLS-TOWER is per masttype weergegeven in Figuur 3 tot en met Figuur 4. Voor elk masttype zijn de belastingen apart bepaald. Alléén voor masttype HB+6/c, bepalend voor het ontwerp van de mastkop, zijn deze ook inclusief bouwphase en afspannen

De uitnutting van de constructie loopt op van blauw (0-25%) tot geel (75-100%). Uit de figuur wordt geconcludeerd dat alle profielen en boutverbindingen voldoen.

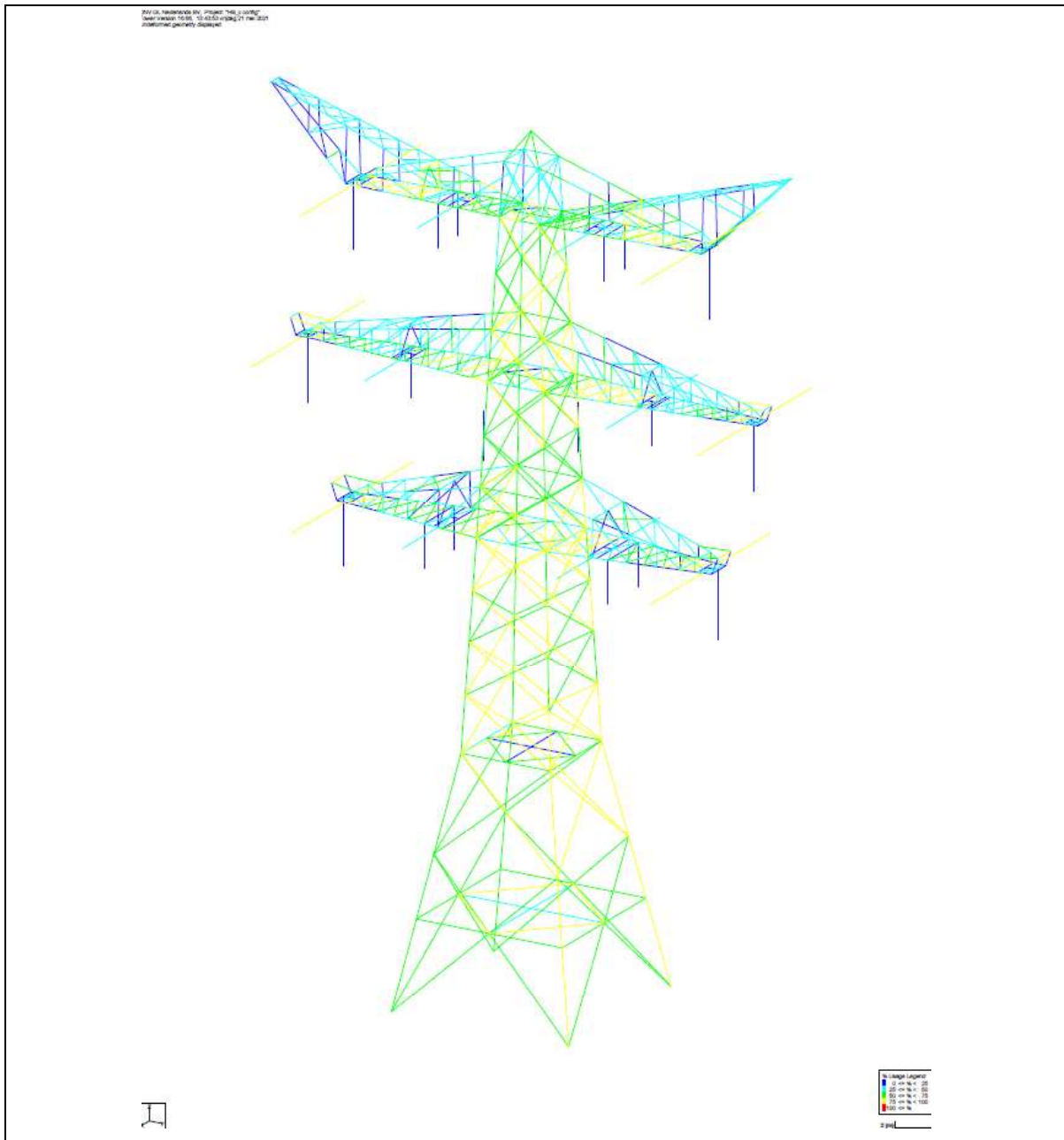

**Figuur 3 Resultaat PLS-TOWER voor masttype HB+0/c**



## 4.2 Toetsing overige onderdelen

In Tabel 8 zijn de resultaten van de uitgevoerde toetsingen weergegeven.

**Tabel 8 Samenvatting uitgevoerde controles**

Controle van	Beoordeling	Referentie
Profielen	Voldoen	Figuur 3 Figuur 4 Appendix B
Knikverkorters	Voldoen	Appendix C
Blokdeuvels randstijl	Voldoen	Appendix D
Liggers	Voldoen	Appendix E
Sterkte-coördinatie	Voldoet	Appendix F

## APPENDIX A

### Geleiderbelastingen

---

Geleiderbelastingen opgenomen:

- Masttype HB+0/c – 140gr
- Masttype HB+0/c – 160gr
- Masttype HB+6/c – 140gr
- Masttype HB+6/c – 160gr
- Masttype HB+6/c bouwfase
- Afspannen



Project: RLL-TLB380  
 Tower: HB+0\_c - 140gr  
 Number: 1184

Auteur: TBR  
 Versie: v12.0

### Geleiderbelastingen

#### Algemeen

Benaming HB+0\_c - 140gr  
 Masttype Hoekmast  
 Aantal circuits 4  
 Configuratie 4-circuit-dubbel verticaal  
 Aantal bliksemgeleiders 2

#### Uitgangspunten

Norm NEN-EN50341-2-15:2019  
 Gevolgklasse initieel CC2  
 Betrouwbaarheidsniveau initieel Nieuwbouw  
 Referentieperiode initieel 50 jaar  
 Betrouwbaarheidsniveau na aanpassing n.v.t.  
 50 jaar  
 Windgebied III  
 Windsnelheid (m/s) 24.5 m/s  
 Terreincategorie II  
 Reductiefactor  $C_{dir}$  1.00  
 IJsg gebied fasegeleider B  
 IJsg gebied bliksemgeleider A

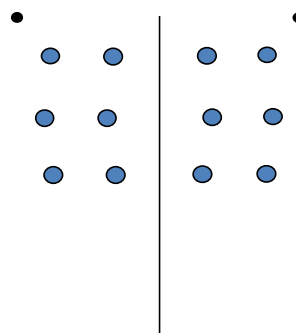

Configuratie geleiders

#### Geleiders Back

Omschrijving	Spanning	Geleider Back	Bundel Ba	IJsg gebied	Toeslag gewicht	Toeslag diameter	Intrekwaarden $P_{back}$
Circuit 1	380 kV	AAAC-AL7 620	4	B	3 %	3 %	1800
Circuit 2	380 kV	AAAC-AL7 620	4	B	3 %	3 %	1800
Circuit 3	150 kV	AAAC-AL7 620	2	B	3 %	3 %	1800
Circuit 4	150 kV	AAAC-AL7 620	2	B	3 %	3 %	1800
Bliksemdraad 1		AACSR 241-AL3-39-A20SA	1	A	2 %	2 %	1800
Bliksemdraad 2		OPGW AFL-226/38	1	A	2 %	2 %	1800

#### Geleiders Ahead

Omschrijving	Spanning	Geleider Ahead	Bundel Ah	IJsg gebied	Toeslag gewicht	Toeslag diameter	Intrekwaarden $P_{ahead}$
Circuit 1	380 kV	AAAC-AL7 620	4	B	3 %	3 %	1800
Circuit 2	380 kV	AAAC-AL7 620	4	B	3 %	3 %	1800
Circuit 3	150 kV	AAAC-AL7 620	2	B	3 %	3 %	1800
Circuit 4	150 kV	AAAC-AL7 620	2	B	3 %	3 %	1800
Bliksemdraad 1		AACSR 241-AL3-39-A20SA	1	A	2 %	2 %	1800
Bliksemdraad 2		OPGW AFL-226/38	1	A	2 %	2 %	1800

#### Isolatoren (1)

Omschrijving	Ophanging	Gewicht [kN]	Lengte [m]	Windopp. [m <sup>2</sup> ]
Circuit 1	Afspanketting	3.00	6.50	1.10
Circuit 2	Afspanketting	3.00	6.50	1.10
Circuit 3	Afspanketting	2.00	4.50	0.80
Circuit 4	Afspanketting	2.00	4.50	0.80
Bliksemdraad 1	Afspanketting	0.10	0.20	0.10
Bliksemdraad 2	Afspanketting	0.10	0.20	0.10

1. Eigenschappen gelden voor geheel van de isolatorset

#### Ophanghoogte en positie in mast

Circuits	Aanduiding	Nummer	Ophanghoogte	Aangrijppunt	Positie in mast Horizontale afstand
Circuit 1	10	380ct1f1	48.0 m	48.0 m	-11.3 m
Circuit 1	11	380ct1f2	38.0 m	38.0 m	-14.8 m
Circuit 1	12	380ct1f3	28.5 m	28.5 m	-11.9 m
Circuit 2	40	380ct2f1	48.0 m	48.0 m	11.3 m
Circuit 2	41	380ct2f2	38.0 m	38.0 m	14.8 m
Circuit 2	42	380ct2f3	28.5 m	28.5 m	11.9 m
Circuit 3	20	150ct3f1	48.0 m	48.0 m	-4.5 m
Circuit 3	21	150ct3f2	38.0 m	38.0 m	-8.0 m
Circuit 3	22	150ct3f3	28.5 m	28.5 m	-5.1 m
Circuit 4	30	150ct4f1	48.0 m	48.0 m	4.5 m
Circuit 4	31	150ct4f2	38.0 m	38.0 m	8.0 m
Circuit 4	32	150ct4f3	28.5 m	28.5 m	5.1 m
Bliksemdraad 1	1	bl1	53.1 m	53.1 m	-17.0 m
Bliksemdraad 2	3	bl2	53.1 m	53.1 m	17.0 m

Project: RLL-TLB380  
 Tower: HB+0\_c - 140gr  
 Number: 1184

**Hoogteaanpassing naastgelegen masten** (aanpassing wind- en weight span)

	Back	Ahead	
Verhoging voor windbelasting	18.0 m	6.0 m	(positief: omhoog)
Verlaging voor verticale belasting	-9.0 m	-9.0 m	(negatief: omlaag, grotere weight span)
Verlaging:	Niet in 0,9EG-combinaties		

**Hoogteafwijking mastbeeld naastgelegen masten en richtingsverandering t.o.v. Lijnrichting**

Circuits	Aanduiding	Nummer	Hoogteverschil		Richtingsverandering	
			$\Delta h$ back	$\Delta h$ ahead	$\Delta y$ back	$\Delta y$ ahead
Circuit 1	10	380ct1f1	0.0	0.0 m	0.0	0.0 m
Circuit 1	11	380ct1f2	0.0	0.0 m	0.0	0.0 m
Circuit 1	12	380ct1f3	0.0	0.0 m	0.0	0.0 m
Circuit 2	40	380ct2f1	0.0	0.0 m	0.0	0.0 m
Circuit 2	41	380ct2f2	0.0	0.0 m	0.0	0.0 m
Circuit 2	42	380ct2f3	0.0	0.0 m	0.0	0.0 m
Circuit 3	20	150ct3f1	0.0	0.0 m	0.0	0.0 m
Circuit 3	21	150ct3f2	0.0	0.0 m	0.0	0.0 m
Circuit 3	22	150ct3f3	0.0	0.0 m	0.0	0.0 m
Circuit 4	30	150ct4f1	0.0	0.0 m	0.0	0.0 m
Circuit 4	31	150ct4f2	0.0	0.0 m	0.0	0.0 m
Circuit 4	32	150ct4f3	0.0	0.0 m	0.0	0.0 m
Bliksemdraad 1	1	bl1	0.0	0.0 m	0.0	0.0 m
Bliksemdraad 2	3	bl2	0.0	0.0 m	0.0	0.0 m

**Lijn- en mastgegevens**

	Back	Ahead
Ruling span $\sqrt{(\Sigma L^3)/\Sigma L}$	400.0	400.0 m
Lijnhoek $\beta$	140 °	
Rotatie mast t.o.v. bissectrice $\theta$	0 °	
Vaklengte	400	400 m
Hoogte onderkant mast t.o.v. maaiveld	0.5 m	
Beschouwde windrichtingen	$\alpha_1$	0 °
Windrichtingen volgens:	$\alpha_2$	45 °
Geleiderbelastingen	$\alpha_3$	90 °
	$\alpha_4$	135 °
	$\alpha_5$	70 °
	$\alpha_6$	110 °

Windrichtingen gelden t.o.v. hoofdrichting mastconstructie, niet t.o.v. bissectrice.

Windrichtingen en positieve richtingen belastingen

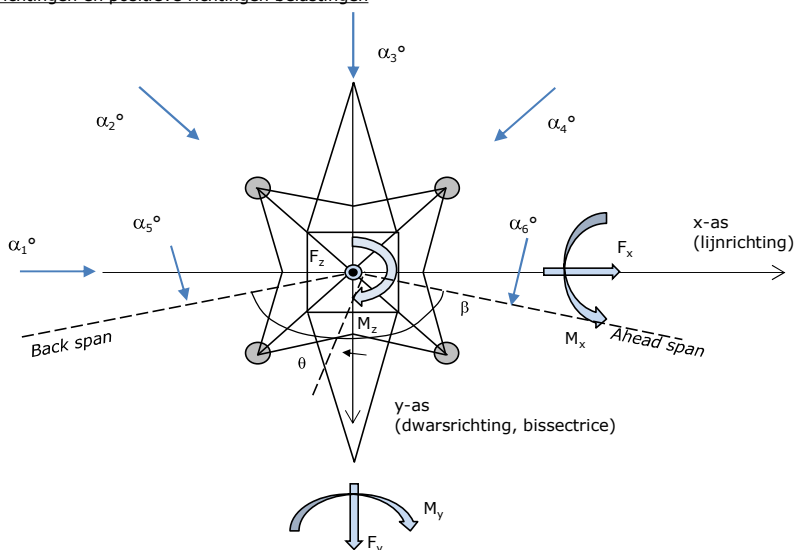

**Beschouwd aantal windrichtingen**

1a	6
3	6
4	1
6	1
Overig	1



Project: RLL-TLB380  
 Tower: HB+0\_c - 140gr  
 Number: 1184

### Geleiderafval

		SPLS - torsie		SPLS - Enkelzijdige trek		5a - geleiderbreuk	
		Aanw.	Afw.	Aanw.	Afw.	Aanw.	Afw.
Circuit 1	380ct1f1	1	0	1	0	1	0
Circuit 1	380ct1f2	1	0	1	0	1	0
Circuit 1	380ct1f3	1	0	1	0	1	0
Circuit 2	380ct2f1	0	1	1	0	1	0
Circuit 2	380ct2f2	0	1	1	0	1	0
Circuit 2	380ct2f3	0	1	1	0	1	0
Circuit 3	150ct3f1	1	0	1	0	1	0
Circuit 3	150ct3f2	1	0	1	0	1	0
Circuit 3	150ct3f3	1	0	1	0	1	0
Circuit 4	150ct4f1	0	1	1	0	1	0
Circuit 4	150ct4f2	0	1	1	0	1	0
Circuit 4	150ct4f3	0	1	1	0	1	0
Bliksemdraad 1	b11	1	0	1	0	1	0
Bliksemdraad 2	b12	0	1	1	0	1	0

### Belastingsituaties SPLS

Beschouwde situaties SPLS: 1 t/m 6, alle mogelijke situaties.

Principe belastingssituaties:

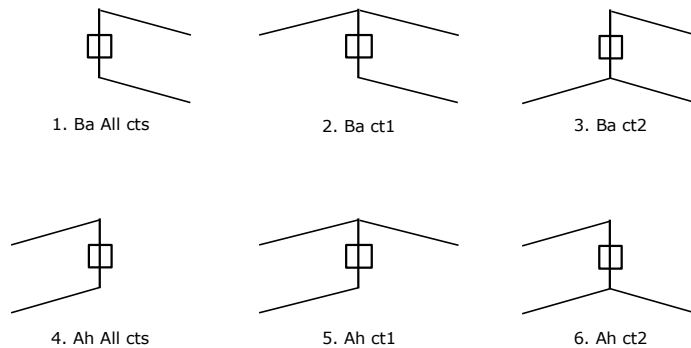

### Belastingsituaties 5a. Geleiderbreuk

Beschouwde situaties geleiderbreuk 5a: 1 en 2, alle mogelijke situaties.

Principe belastingssituaties:

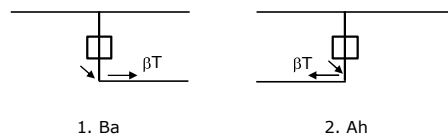

Project: RLL-TLB380  
 Tower: HB+0\_c - 140gr  
 Number: 1184

### Belastingsituaties 6. Bouw- en onderhoud

Onder 6a wordt de belasting door aanwezigheid lijnwagen of lijnfiets in combinatie met puntlast op traverse in rekening gebracht. Combinatie 6b bevat geen belastingen in geleider of op traverse. Deze combinatie is toegevoegd om te kunnen combineren met separate controle bordessen etc. De situaties worden in ULS en in iedere SPLS-situatie (in geval van hoekmast) toegepast.

	Fase	Bliksem
Lijnwagen	4.0 kN	2.0 kN
Puntlast op traverse	1.0 kN	1.0 kN

Beschouwde situaties bouw- en onderhoud 6a: 1 t/m 4, alle mogelijke situaties.

Aanwezigheid lijnwagen: Circuit, belasting tegelijk aanwezig in alle geleiders per circuit.

Principe belastingssituaties:

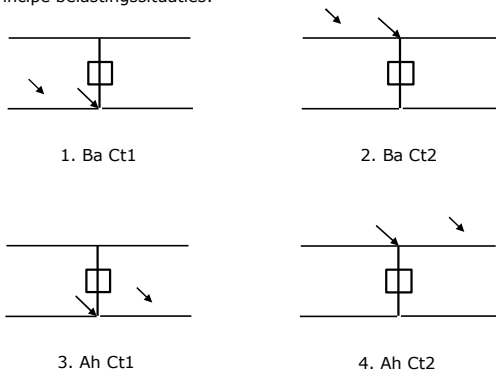

### Belastingsituaties 8. Lijndansen als statische belasting

Geleider		
Steunmast fase	0.866 W	1.5 W
Steunmast bliksem	1.5 EDS	1.5 W
Hoekmast fase en bliksem	1.5 EDS	1.5 W

Beschouwde situaties lijndansen 8: 1 en 2, alle mogelijke situaties.

Belasting tegelijk aanwezig in alle geleiders van het circuit.

Principe belastingssituaties:

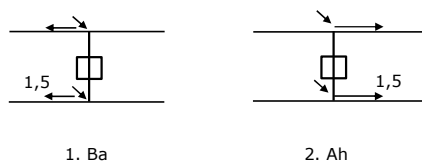

### Belastingcombinatie 8. Lijndansen als dynamische belasting

Alleen van toepassing op hoek- en eindmasten  
 Belasting bestaat uit EDS-trekbelasting in één van de geleiders aan één zijde van de mast  
 Door gebruiker via het belastingsspectrum van tabel 4.11/NL.1 om te zetten naar spanningspectrum

Project: RLL-TLB380  
 Tower: HB+0\_c - 140gr  
 Number: 1184

## Mastconstructie

### Eigenschappen

Masttype	Hoekmast	
Mastbenaming	HB+0_c - 140gr	
Voetplaat t.o.v. maaiveld	0.5 m	
Masthoogte t.o.v. voetplaat	53.1 m	
Gewicht mast	997.6 kN	
<i>Breedte en helling mast bij fundatie</i>		
	x-ri.	y-ri.
Pootsprei	11.76	11.76 m
Helling van de randstijl	0.190	0.190 -
Factor spatkracht	1.1	1.1 -

### Berekening windbelasting

Dynamische invloed $G_T$	1.00 ( <i>Masthoogte &lt; 60 m</i> )
Windbelasting overhoeks op mastlichaam evenredig met:	$(A1C1\sin^2(\phi)+A2C2\cos^2(\phi))$
Windbelasting overhoeks op traverse evenredig met:	$(A1C1\sin^2(\phi)+A2C2\cos^2(\phi))$
Vergroting wind overhoeks mastlichaam	$(1+0,2\sin^2(2\phi))$
Vergroting wind overhoeks traverse	$(1+0,2\sin^2(2\phi))$
Factor wind evenwijdig t.o.v. haaks op traverse	0.4

### Eigenschappen mastsecties langsrichting (vooraanzicht, yz-vlak)

Omschrijving	h [m]	b <sub>1</sub> [m]	b <sub>2</sub> [m]	Δh [m]	Δ <sub>x</sub> [m]	A <sub>0</sub> [m <sup>2</sup> ]	A <sub>1</sub> [m <sup>2</sup> ]	χ = A <sub>1</sub> /A <sub>0</sub> [-]	C <sub>t</sub>
Broekstuk	15.40	11.76	5.91	15.40	0.190	136.07	31.83	0.23	2.79
Eerste tussenstuk	22.20	5.91	5.23	6.80	0.050	37.88	13.54	0.36	2.34
Tweede tussenstuk	28.50	5.23	4.60	6.30	0.050	30.96	9.94	0.32	2.46
Bovenstuk 1	38.00	4.60	3.65	9.50	0.050	39.19	12.67	0.32	2.45
Bovenstuk 2	51.40	3.65	2.31	13.40	0.050	39.93	13.01	0.33	2.45
Topstuk	53.10	2.31		1.70		1.96	0.33	0.17	3.08
Ondertraverse	28.50	9.95		3.10		15.42	4.52	0.29	2.56
Middentraverse	38.00	13.30		3.20		21.28	6.53	0.31	2.51
Boventraverse	48.00	15.68		5.10		39.97	7.67	0.19	2.97

### Eigenschappen mastsecties dwarsrichting (zijaanzicht, xz-vlak)

Omschrijving	h [m]	b <sub>1</sub> [m]	b <sub>2</sub> [m]	Δh [m]	Δ <sub>x</sub> [m]	A <sub>0</sub> [m <sup>2</sup> ]	A <sub>1</sub> [m <sup>2</sup> ]	χ = A <sub>1</sub> /A <sub>0</sub> [-]	C <sub>t</sub>
Broekstuk	15.40	11.76	5.91	15.40	0.190	136.07	31.83	0.23	2.79
Eerste tussenstuk	22.20	5.91	5.23	6.80	0.050	37.88	13.54	0.36	2.34
Tweede tussenstuk	28.50	5.23	4.60	6.30	0.050	30.96	9.94	0.32	2.46
Bovenstuk 1	38.00	4.60	3.65	9.50	0.050	39.19	12.67	0.32	2.45
Bovenstuk 2	51.40	3.65	2.31	13.40	0.050	39.93	13.01	0.33	2.45
Topstuk	53.10	2.31		1.70		1.96	0.33	0.17	3.08
Ondertraverse	28.50	9.95		3.10		15.42	4.52	0.29	2.56
Middentraverse	38.00	13.30		3.20		21.28	6.53	0.31	2.51
Boventraverse	48.00	15.68		5.10		39.97	7.67	0.19	2.97

NB: oppervlakte traverse dwarsrichting van de tabel wordt in berekening gereduceerd.  
 NB: oppervlakte traverse per zijde, dus helft van totaal van twee traveses.

Project: RLL-TLB380  
 Tower: HB+0\_c - 140gr  
 Number: 1184

#### Windoppervlak feeders telecominstallaties

Onderdeel	A (m <sup>2</sup> /m)	Factor	Δh	A <sub>1</sub>
Broekstuk	0.14	0.71	15.4	1.5
Eerste tussenstuk	0.14	0.71	6.8	0.7
Tweede tussenstuk	0.14	0.71	6.3	0.6
Bovenstuk 1	0.14	0.71	9.5	0.9
Bovenstuk 2				

#### Invoer antennes

Omschrijving	A (m <sup>2</sup> )	h (m)	C <sub>i</sub> (m)
Antenne top			
Antenne o.t.	4.7	34.7	1.5

#### Belastingen mastsectie langsrichting (x-richting) per windrichting

Omschrijving	P <sub>w</sub> [kN/m <sup>2</sup> ]	F <sub>x1</sub> [kN]	F <sub>x2</sub> [kN]	F <sub>x3</sub> [kN]	F <sub>x4</sub> [kN]	h <sub>ef</sub> [m]	M <sub>y1</sub> [kNm]	M <sub>y2</sub> [kNm]	M <sub>y3</sub> [kNm]	M <sub>y4</sub> [kNm]
Broekstuk	0.70	62.2	52.8	0.0	-52.8	7.7	479.0	406.5	0.0	-406.5
Eerste tussenstuk	0.86	27.3	23.2	0.0	-23.2	18.8	513.6	435.8	0.0	-435.8
Tweede tussenstuk	0.94	23.0	19.5	0.0	-19.5	25.4	584.0	495.5	0.0	-495.5
Bovenstuk 1	1.02	31.8	27.0	0.0	-27.0	33.3	1056.2	896.2	0.0	-896.2
Bovenstuk 2	1.10	35.1	29.8	0.0	-29.8	44.7	1567.6	1330.2	0.0	-1330.2
Topstuk	1.15	1.2	1.0	0.0	-1.0	52.3	60.7	51.5	0.0	-51.5
Ondertraverse	0.98	22.8	13.5	0.0	-13.5	29.5	672.6	399.5	0.0	-399.5
Middentraverse	1.06	34.9	20.7	0.0	-20.7	39.1	1361.6	808.7	0.0	-808.7
Boventraverse	1.13	51.6	30.6	0.0	-30.6	49.7	2564.3	1523.1	0.0	-1523.1
<b>Totaal</b>		<b>289.8</b>	<b>218.1</b>	<b>0.0</b>	<b>-218.1</b>		<b>8859.6</b>	<b>6347.0</b>	<b>0.0</b>	<b>-6347.0</b>

#### Belastingen mastsectie dwarsrichting (y-richting) per windrichting

Omschrijving	P <sub>w</sub> [kN/m <sup>2</sup> ]	F <sub>y1</sub> [kN]	F <sub>y2</sub> [kN]	F <sub>y3</sub> [kN]	F <sub>y4</sub> [kN]	h <sub>ef</sub> [m]	M <sub>x1</sub> [kNm]	M <sub>x2</sub> [kNm]	M <sub>x3</sub> [kNm]	M <sub>x4</sub> [kNm]
Broekstuk	0.70	0.0	52.8	62.2	52.8	7.7	0.0	406.5	479.0	406.5
Eerste tussenstuk	0.86	0.0	23.2	27.3	23.2	18.8	0.0	435.8	513.6	435.8
Tweede tussenstuk	0.94	0.0	19.5	23.0	19.5	25.4	0.0	495.5	584.0	495.5
Bovenstuk 1	1.02	0.0	27.0	31.8	27.0	33.3	0.0	896.2	1056.2	896.2
Bovenstuk 2	1.10	0.0	29.8	35.1	29.8	44.7	0.0	1330.2	1567.6	1330.2
Topstuk	1.15	0.0	1.0	1.2	1.0	52.3	0.0	51.5	60.7	51.5
Ondertraverse	0.98	0.0	13.5	9.1	13.5	29.5	0.0	399.5	269.0	399.5
Middentraverse	1.06	0.0	20.7	13.9	20.7	39.1	0.0	808.7	544.6	808.7
Boventraverse	1.13	0.0	30.6	20.6	30.6	49.7	0.0	1523.1	1025.7	1523.1
<b>Totaal</b>		<b>0.0</b>	<b>218.1</b>	<b>224.3</b>	<b>218.1</b>		<b>0.0</b>	<b>6347.0</b>	<b>6100.5</b>	<b>6347.0</b>

#### Resulterende belastingen vanuit mastconstructie incl. antenne zonder geleiders niveau fundatie (kar. waarde)

Belasting / windrichting	F <sub>x</sub> [kN]	F <sub>y</sub> [kN]	F <sub>z</sub> [kN]	M <sub>x</sub> [kNm]	M <sub>y</sub> [kNm]	M <sub>z</sub> [kNm]
Permanente belasting	0	0	998	0	0	0
Windrichting 0°	297	0	0	0	9111	0
Windrichting 45°	223	223	0	6525	6525	0
Windrichting 90°	0	232	0	6352	0	0
Windrichting 135°	-223	223	0	6525	-6525	0

Project: RLL-TLB380  
 Tower: HB+0\_c - 140gr  
 Number: 1184

### Tussenresultaten geleiderbelastingen

#### Geleiders back

Circuit	Geleider	Diameter [mm]	A [mm <sup>2</sup> ]	G [N/m]	E [N/mm <sup>2</sup> ]	$\alpha T$ [-]
Circuit 1	AAAC-AL7 620	32.4	621.0	17.71	56000	2.30E-05
Circuit 2	AAAC-AL7 620	32.4	621.0	17.71	56000	2.30E-05
Circuit 3	AAAC-AL7 620	32.4	621.0	17.71	56000	2.30E-05
Circuit 4	AAAC-AL7 620	32.4	621.0	17.71	56000	2.30E-05
Bliksemdraad 1	AACSR 241-AL3-39-A20SA	21.8	281.0	9.38	70165	1.97E-05
Bliksemdraad 2	OPGW AFL-226/38	21.7	264.0	9.13	72000	1.98E-05

#### Geleiders ahead

Circuit	Geleider	Diameter [mm]	A [mm <sup>2</sup> ]	G [N/m]	E [N/mm <sup>2</sup> ]	$\alpha T$ [-]
Circuit 1	AAAC-AL7 620	32.4	621.0	17.71	56000	2.30E-05
Circuit 2	AAAC-AL7 620	32.4	621.0	17.71	56000	2.30E-05
Circuit 3	AAAC-AL7 620	32.4	621.0	17.71	56000	2.30E-05
Circuit 4	AAAC-AL7 620	32.4	621.0	17.71	56000	2.30E-05
Bliksemdraad 1	AACSR 241-AL3-39-A20SA	21.8	281.0	9.38	70165	1.97E-05
Bliksemdraad 2	OPGW AFL-226/38	21.7	264.0	9.13	72000	1.98E-05

#### Verticale belasting back

Circuit	Bundel [-]	Toeslag [%]	$W_{z,G}$ [N/m]	IJsgebied	Formule	$W_{z,ijs}$ [N/m]	$W_{z,ijs,bundel}$ [N/m]
Circuit 1	4	3	73.0	B	4+0,2d	10.5	41.9
Circuit 2	4	3	73.0	B	4+0,2d	10.5	41.9
Circuit 3	2	3	36.5	B	4+0,2d	10.5	21.0
Circuit 4	2	3	36.5	B	4+0,2d	10.5	21.0
Bliksemdraad 1	1	2	9.6	A	15+0,4d	23.7	23.7
Bliksemdraad 2	1	2	9.3	A	15+0,4d	23.7	23.7

#### Verticale belasting ahead

Circuit	Bundel [-]	Toeslag [%]	$W_{z,G}$ [N/m]	IJsgebied	Formule	$W_{z,ijs}$ [N/m]	$W_{z,ijs,bundel}$ [N/m]
Circuit 1	4	3	73.0	B	4+0,2d	10.5	41.9
Circuit 2	4	3	73.0	B	4+0,2d	10.5	41.9
Circuit 3	2	3	36.5	B	4+0,2d	10.5	21.0
Circuit 4	2	3	36.5	B	4+0,2d	10.5	21.0
Bliksemdraad 1	1	2	9.6	A	15+0,4d	23.7	23.7
Bliksemdraad 2	1	2	9.3	A	15+0,4d	23.7	23.7

#### Isolatoren

Geleider	$G_{isolator}$ [kN]	Aantal	$F_{v,iso}$ [kN]	Lengte [m]	Windopp. [m <sup>2</sup> ]	Windhoogte [m]	Stuwdruk [kN/m <sup>2</sup> ]	Vormfactor [-]	$F_{h,iso}$ [kN]
380ct1f1	3.00	1	3	6.5	1.1	48.50	1.13	1.2	1.49
380ct1f2	3.00	1	3	6.5	1.1	38.50	1.06	1.2	1.40
380ct1f3	3.00	1	3	6.5	1.1	29.00	0.98	1.2	1.29
380ct2f1	3.00	1	3	6.5	1.1	48.50	1.13	1.2	1.49
380ct2f2	3.00	1	3	6.5	1.1	38.50	1.06	1.2	1.40
380ct2f3	3.00	1	3	6.5	1.1	29.00	0.98	1.2	1.29
150ct3f1	2.00	1	2	4.5	0.8	48.50	1.13	1.2	1.08
150ct3f2	2.00	1	2	4.5	0.8	38.50	1.06	1.2	1.02
150ct3f3	2.00	1	2	4.5	0.8	29.00	0.98	1.2	0.94
150ct4f1	2.00	1	2	4.5	0.8	48.50	1.13	1.2	1.08
150ct4f2	2.00	1	2	4.5	0.8	38.50	1.06	1.2	1.02
150ct4f3	2.00	1	2	4.5	0.8	29.00	0.98	1.2	0.94
bl1	0.10	1	0.1	0.2	0.1	53.60	1.16	1.2	0.14
bl2	0.10	1	0.1	0.2	0.1	53.60	1.16	1.2	0.14

Project: RLL-TLB380  
 Tower: HB+0\_c - 140gr  
 Number: 1184

#### Windbelasting back

Geleider	hoogte		$G_{c\_dwars}$	$G_{c\_trek}$	$C_c$	$d_{toeslag}$	$w_y$	$w_{y,vak}$	$D_{ijs,toeslag}$	$w_{y,ijs}$	$w_{y,ijs,vak}$
	wind	Stuwdruk									
	[m]	[kN/m <sup>2</sup> ]	[-]	[-]	[-]	[mm]	[N/m]	[N/m]	[mm]	[N/m]	[N/m]
380ct1f1	50.1	1.14	0.62	0.68	0.96	33.37	89.8	98.8	51.8	174.5	191.9
380ct1f2	40.1	1.07	0.60	0.66	0.98	33.37	84.0	92.4	51.8	159.9	175.9
380ct1f3	30.6	0.99	0.58	0.64	1.00	33.37	77.1	84.9	51.8	143.2	157.6
380ct2f1	50.1	1.14	0.62	0.68	0.96	33.37	89.8	98.8	51.8	174.5	191.9
380ct2f2	40.1	1.07	0.60	0.66	0.98	33.37	84.0	92.4	51.8	159.9	175.9
380ct2f3	30.6	0.99	0.58	0.64	1.00	33.37	77.1	84.9	51.8	143.2	157.6
150ct3f1	50.1	1.14	0.62	0.68	0.96	33.37	44.9	49.4	51.8	87.3	95.9
150ct3f2	40.1	1.07	0.60	0.66	0.98	33.37	42.0	46.2	51.8	79.9	88.0
150ct3f3	30.6	0.99	0.58	0.64	1.00	33.37	38.6	42.4	51.8	71.6	78.8
150ct4f1	50.1	1.14	0.62	0.68	0.96	33.37	44.9	49.4	51.8	87.3	95.9
150ct4f2	40.1	1.07	0.60	0.66	0.98	33.37	42.0	46.2	51.8	79.9	88.0
150ct4f3	30.6	0.99	0.58	0.64	1.00	33.37	38.6	42.4	51.8	71.6	78.8
bl1	55.2	1.17	0.62	0.69	1.18	22.24	19.1	21.0	63.1	55.2	60.6
bl2	55.2	1.17	0.62	0.69	1.18	22.13	19.0	20.9	63.0	55.1	60.5

#### Windbelasting ahead

Geleider	hoogte		$G_{c\_dwars}$	$G_{c\_trek}$	$C_c$	$d_{toeslag}$	$w_y$	$w_{y,vak}$	$D_{ijs,toeslag}$	$w_{y,ijs}$	$w_{y,ijs,vak}$
	wind	Stuwdruk									
	[m]	[kN/m <sup>2</sup> ]	[-]	[-]	[-]	[mm]	[N/m]	[N/m]	[mm]	[N/m]	[N/m]
380ct1f1	44.1	1.10	0.61	0.67	0.97	33.37	86.5	95.1	51.8	166.0	182.6
380ct1f2	34.1	1.02	0.59	0.65	0.99	33.37	79.9	87.9	51.8	149.7	164.8
380ct1f3	24.6	0.93	0.56	0.62	1.02	33.37	71.7	78.9	51.8	130.4	143.6
380ct2f1	44.1	1.10	0.61	0.67	0.97	33.37	86.5	95.1	51.8	166.0	182.6
380ct2f2	34.1	1.02	0.59	0.65	0.99	33.37	79.9	87.9	51.8	149.7	164.8
380ct2f3	24.6	0.93	0.56	0.62	1.02	33.37	71.7	78.9	51.8	130.4	143.6
150ct3f1	44.1	1.10	0.61	0.67	0.97	33.37	43.2	47.6	51.8	83.0	91.3
150ct3f2	34.1	1.02	0.59	0.65	0.99	33.37	39.9	43.9	51.8	74.9	82.4
150ct3f3	24.6	0.93	0.56	0.62	1.02	33.37	35.8	39.5	51.8	65.2	71.8
150ct4f1	44.1	1.10	0.61	0.67	0.97	33.37	43.2	47.6	51.8	83.0	91.3
150ct4f2	34.1	1.02	0.59	0.65	0.99	33.37	39.9	43.9	51.8	74.9	82.4
150ct4f3	24.6	0.93	0.56	0.62	1.02	33.37	35.8	39.5	51.8	65.2	71.8
bl1	49.2	1.13	0.62	0.68	1.19	22.24	18.4	20.2	63.1	52.8	58.0
bl2	49.2	1.13	0.62	0.68	1.19	22.13	18.3	20.1	63.0	52.7	57.9

NB: belastingen  $w_v$  gelden voor bundel

Project: RLL-TLB380  
 Masttype: HB+0\_c - 140gr  
 Mast: 1184

Auteur: TBR  
 Versie: v12.0

### Geleiderbelastingen

**Uitgangspunten**  
 Betrouwbaarheidsniveau Nieuwbouw CC2  
 Referentieperiode 50 jaar

<b>ULS</b> (bezwijksterkte)		<b>NEN-EN50341-2-15:2019</b>							
Belastingsgeval	omschrijving	Temp °C	$\gamma_G$		$\gamma_Q$			$\gamma_a$ $A_k$	
			$G_{k,mast}$	$G_{k,geleider}$	$Q_{pk}$	$Q_{wk}$	$Q_{ik}$		
ULS 1a	Wind	10°	1.20	1.20	0.00	1.50	0.00	0.0	
ULS 1a_0,9	Wind 0,9Gk alleen mast	10°	0.90	1.20	0.00	1.50	0.00	0.0	
ULS 1a_0,9_0,9	Wind 0,9Gk ook geleider	10°	0.90	0.90	0.00	1.50	0.00	0.0	
ULS 3	Wind+ijs	-5°	1.20	1.20	0.00	0.45	1.50	0.0	
ULS 3_0,9	Wind+ijs 0,9	-5°	0.90	1.20	0.00	0.45	1.50	0.0	
ULS 4	Koude+wind	-20°	1.20	1.20	0.00	0.30	0.00	0.0	
ULS 4_0,9	Koude+wind 0,9	-20°	0.90	1.20	0.00	0.30	0.00	0.0	
ULS 5a	Torsiebelastingen	10°	1.00	1.00	1.00	0.00	0.00	1.0	
ULS 5b	Longitudinale belastingen	10°	1.00	1.00	0.00	0.00	0.00	1.0	
ULS 6	Bouw en onderhoud	5°	1.20	1.20	1.50	0.30	0.00	0.0	
ULS 6_0,9	Bouw en onderhoud	5°	1.20	1.20	0.00	0.30	0.00	0.0	
ULS 7	Permanent	10°	1.35	1.35	0.00	0.00	0.00	0.0	
ULS 8	Special	10°	1.00	1.00	0.00	0.00	0.00	1.0	
<b>SPLS</b> (Bezwijksterkte, enkel voor hoekmasten: afwezigheid geleiders)			$\gamma_G$		$\gamma_Q$				
			$G_k$	$G_k$	$Q_{pk}$	$Q_{wk}$	$Q_{ik}$	$A_k$	
SPLS 1a	Wind	10°	1.20	1.20	0.0	0.78	0.00	0.0	
SPLS 1a_0,9	Wind 0,9	10°	0.90	1.20	0.0	0.78	0.00	0.0	
SPLS 1a_0,9_0,9	Wind 0,9	10°	0.90	0.90	0.0	0.78	0.00	0.0	
SPLS 3	Wind+ijs	-5°	1.20	1.20	0.0	0.36	0.34	0.0	
SPLS 3_0,9	Wind+ijs 0,9	-5°	0.90	1.20	0.0	0.36	0.34	0.0	
SPLS 4	Koude+wind	-20°	1.20	1.20	0.0	0.24	0.00	0.0	
SPLS 4_0,9	Koude+wind 0,9	-20°	0.90	1.20	0.0	0.24	0.00	0.0	
SPLS 6	Bouw en onderhoud	5°	1.20	1.20	1.2	0.24	0.0	0.0	
SPLS 6_0,9	Bouw en onderhoud	5°	1.20	1.20	0.0	0.24	0.0	0.0	
<b>SLS</b> (controle van de vervormingen, vermoeiing, EDS)			$G_k$		$Q_{pk}$	$Q_{wk}$	$Q_{ik}$	$A_k$	
			$G_k$	$G_k$	$Q_{pk}$	$Q_{wk}$	$Q_{ik}$	$A_k$	
SLS 1a	Wind	10°	1.00	1.00	0.0	1.00	0.0	0.0	
SLS 3	Wind+ijs	-5°	1.00	1.00	0.0	0.30	1.00	0.0	
SLS 4	Wind	-20°	1.00	1.00	0.0	0.20	0.0	0.0	
SLS 6	Bouw en onderhoud	5°	1.00	1.00	0.0	0.20	0.0	0.0	
SLS 7	PB (EDS, geen wind)	10°	1.00	1.00	0.0	0.00	0.0	0.0	

Aantal windrichtingen 6  
 Aantal belastingcombinaties ULS 100  
 Aantal belastingcombinaties SPLS 246  
 Aantal belastingcombinaties SLS 15  
 Aantal knooplasten 12274

Project: RLL-TLB380  
 Masttype: HB+0\_c - 140gr  
 Mast: 1184

### Samenvattingstabellen geleiderbelastingen

In de onderstaande vier tabellen is weergegeven:

- De maximale geleiderbelasting in het globale assenstelsel, gesplitst in aandeel van back en ahead span
- De gecombineerde geleiderbelasting (Ba+Ah) in het globale assenstelsel met in het lokale assenstelsel de maximaal optredende trekkracht. Componenten Fx en Fy als absolute waarde
- De alledaagse (EDS) waarden van de gecombineerde geleiderbelastingen (Ba+Ah) met bijbehorende trekkrachten
- Controle op uplift, waar een negatieve waarde duidt op uplift

#### Maximale waarden voor back en ahead span

Geleider	Fx_ba [kN]	Fx_ah [kN]	Fy_ba [kN]	Fy_ah [kN]	Fz_ba [kN]	Fz_ah [kN]
bl1	-61.8	61.4	27.8	27.5	11.1	11.0
380ct1f1	-249.6	247.6	115.6	112.9	39.8	39.7
380ct1f2	-246.2	244.1	110.8	107.4	39.7	39.6
380ct1f3	-242.7	240.3	105.1	100.7	39.6	39.5
Post-isolato	0.0	0.0	0.0	0.0	0.0	
Post-isolato	0.0	0.0	0.0	0.0	0.0	
Post-isolato	0.0	0.0	0.0	0.0	0.0	
380ct2f1	-249.6	247.6	115.6	112.9	39.8	39.7
380ct2f2	-246.2	244.1	110.8	107.4	39.7	39.6
380ct2f3	-242.7	240.3	105.1	100.7	39.6	39.5
150ct3f1	-124.7	123.8	58.3	56.9	21.3	21.3
150ct3f2	-123.1	122.0	55.9	54.2	21.3	21.3
150ct3f3	-121.3	120.1	53.0	50.8	21.3	21.3
150ct4f1	-124.7	123.8	58.3	56.9	21.3	21.3
150ct4f2	-123.1	122.0	55.9	54.2	21.3	21.3
150ct4f3	-121.3	120.1	53.0	50.8	21.3	21.3
bl2	-60.9	60.5	27.5	27.1	11.0	10.9
Post-isolato	0.0	0.0	0.0	0.0	0.0	
Post-isolato	0.0	0.0	0.0	0.0	0.0	
Post-isolato	0.0	0.0	0.0	0.0	0.0	

#### Min. Weight span (m)

Weight spar Combinatie1

Geleider	SLS 1a	SLS 4	SLS 7
bl1	483.1	497.1	481.0
380ct1f1	481.8	496.1	481.0
380ct1f2	481.7	495.8	481.0
380ct1f3	481.6	495.5	481.0
Post-isolator 1			
Post-isolator 2			
Post-isolator 3			
380ct2f1	481.8	496.1	481.0
380ct2f2	481.7	495.8	481.0
380ct2f3	481.6	495.5	481.0
150ct3f1	481.8	496.1	481.0
150ct3f2	481.7	495.8	481.0
150ct3f3	481.6	495.5	481.0
150ct4f1	481.8	496.1	481.0
150ct4f2	481.7	495.8	481.0
150ct4f3	481.6	495.5	481.0
bl2	483.2	497.3	481.0
Post-isolator 4			
Post-isolator 5			
Post-isolator 6			

#### Max. Weight span (m)

Weight spar Combinatie1

Geleider	ULS 1a	ULS 3
bl1	564.6	463.1
380ct1f1	522.6	479.3
380ct1f2	518.2	478.3
380ct1f3	512.8	477.2
Post-isolator 1		
Post-isolator 2		
Post-isolator 3		
380ct2f1	522.6	479.3
380ct2f2	518.2	478.3
380ct2f3	512.8	477.2
150ct3f1	522.6	479.3
150ct3f2	518.2	478.3
150ct3f3	512.8	477.2
150ct4f1	522.6	479.3
150ct4f2	518.2	478.3
150ct4f3	512.8	477.2
bl2	567.0	462.7
Post-isolator 4		
Post-isolator 5		
Post-isolator 6		

Omhullende weight span over alle combinaties (incl. 0,9 combinaties)

Voor alle geleiders

Max. weight span	564.6 m
Min. weight span	110.0 m

Wind / Weight span verhouding

1.412 -
0.275 -



Project: RLL-TLB380  
 Masttype: HB+0\_c - 140gr  
 Mast: 1184

**Maximale waarden back+ahead span      Maximale waarden trekkracht geleider**

Geleider	Fx	Fy	Fz	Ft_ba	Ft_ah
	[kN]	[kN]	[kN]	[kN]	[kN]
bl1	36.7	53.3	11.1	-67.6	67.1
380ct1f1	195.1	210.8	39.8	-271.5	269.2
380ct1f2	191.4	203.2	39.7	-267.5	264.9
380ct1f3	187.5	198.1	39.6	-263.3	260.2
Post-isolato	4.2	4.2	6.8	0.0	
Post-isolato	3.2	3.2	4.7	0.0	
Post-isolato	4.9	4.9	6.8	0.0	
380ct2f1	195.1	210.8	39.8	-271.5	269.2
380ct2f2	191.4	203.2	39.7	-267.5	264.9
380ct2f3	187.5	198.1	39.6	-263.3	260.2
150ct3f1	102.8	106.2	21.3	-135.8	134.6
150ct3f2	102.7	101.9	21.3	-133.8	132.4
150ct3f3	102.7	99.3	21.3	-131.6	130.1
150ct4f1	102.8	106.2	21.3	-135.8	134.6
150ct4f2	102.7	101.9	21.3	-133.8	132.4
150ct4f3	102.7	99.3	21.3	-131.6	130.1
bl2	36.2	52.7	11.0	-66.7	66.1
Post-isolato	4.2	4.2	6.8	0.0	
Post-isolato	3.2	3.2	4.7	0.0	
Post-isolato	4.9	4.9	6.8	0.0	

**EDS-belastingen geleiders**

Geleider	Fx	Fy	Fz	Ft_ba	Ft_ah
	[kN]	[kN]	[kN]	[kN]	[kN]
bl1	16.2	5.9	2.4	-17.2	17.2
380ct1f1	123.4	44.9	20.5	-131.3	131.3
380ct1f2	123.4	44.9	20.5	-131.3	131.3
380ct1f3	123.4	44.9	20.5	-131.3	131.3
Post-isolato	0.0	0.0	5.0	0.0	
Post-isolato	0.0	0.0	3.5	0.0	
Post-isolato	0.0	0.0	5.0	0.0	
380ct2f1	123.4	44.9	20.5	-131.3	131.3
380ct2f2	123.4	44.9	20.5	-131.3	131.3
380ct2f3	123.4	44.9	20.5	-131.3	131.3
150ct3f1	61.7	22.5	10.8	-65.7	65.7
150ct3f2	61.7	22.5	10.8	-65.7	65.7
150ct3f3	61.7	22.5	10.8	-65.7	65.7
150ct4f1	61.7	22.5	10.8	-65.7	65.7
150ct4f2	61.7	22.5	10.8	-65.7	65.7
150ct4f3	61.7	22.5	10.8	-65.7	65.7
bl2	15.7	5.7	2.3	-16.8	16.8
Post-isolato	0.0	0.0	5.0	0.0	
Post-isolato	0.0	0.0	3.5	0.0	
Post-isolato	0.0	0.0	5.0	0.0	

**Controle uplift SLS-wind**

Combinatie: Geleider	Fz_ba	Fz_ah
	[kN]	[kN]
SLS 4		
bl1	0.0	0.0
380ct1f1	0.0	0.0
380ct1f2	0.0	0.0
380ct1f3	0.0	0.0
Post-isolato	0.0	
Post-isolato	0.0	
Post-isolato	0.0	
380ct2f1	0.0	0.0
380ct2f2	0.0	0.0
380ct2f3	0.0	0.0
150ct3f1	0.0	0.0
150ct3f2	0.0	0.0
150ct3f3	0.0	0.0
150ct4f1	0.0	0.0
150ct4f2	0.0	0.0
150ct4f3	0.0	0.0
bl2	0.0	0.0
Post-isolato	0.0	
Post-isolato	0.0	
Post-isolato	0.0	

Project: RLL-TLB380  
 Masttype: HB+0\_c - 140gr  
 Mast: 1184

**ULS-fundatiebelasting combinatie 1 en 3 wind haaks op de lijn of bissectrice en EDS, vanuit geleiders**

Combinatie	Combination	$F_x$ [kN]	$F_y$ [kN]	$F_z$ [kN]	$M_x$ [kNm]	$M_y$ [kNm]	$M_z$ [kNm]
ULS 1a_90		-49	1916	526	74870	-1824	0
ULS 1a_0.9_0		43	978	335	37764	1684	0
ULS 1a_0.9_0.9_90		-55	1826	200	71459	-2043	0
ULS 3_0		18	1591	789	61941	722	0
SLS 7		0	832	412	32092	0	0

**ULS-fundatiebelasting combinatie 1 en 3 wind haaks op de lijn of bissectrice en EDS, totaal geleiders en mast**

Combinatie	$F_x$ [kN]	$F_y$ [kN]	$F_z$ [kN]	$M_x$ [kNm]	$M_y$ [kNm]	$M_z$ [kNm]
ULS 1a_90	-49	2263	1723	84399	-1824	0
ULS 1a_0.9_0.9_90	-55	2173	1098	80988	-2043	0
SLS 7	0	832	1410	32092	0	0

**Fundatiebelastingen, selectie belastingcombinaties op basis grootste waarde**

Combinatie	$F_x$ [kN]	$F_y$ [kN]	$F_z$ [kN]	$M_x$ [kNm]	$M_y$ [kNm]	$M_z$ [kNm]
ULS 1a_0.9_90	-49	2263	1189	<b>84400</b>	-1824	0
SPLS 3_70 Ah All Cts	-1761	816	1534	30798	<b>-68851</b>	9
SPLS 3_70 Ba Ct1	788	1094	1646	42748	30053	<b>-9576</b>
SPLS 3_0.9_70 Ah All Cts	-1761	816	1096	<b>30799</b>	<b>-68851</b>	9

*Noot: grootste waarden kunnen in meerdere combinaties voorkomen, een combinatie is weergegeven.*

**Oplegreacties op fundering per randstijl**

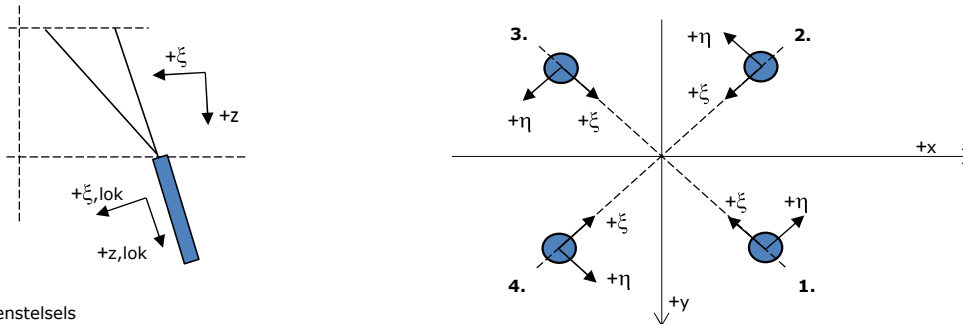

Assenstelsels

**Maximale drukbelasting**

Stijl	Combinatie	$R_x$ [kN]	$R_y$ [kN]	$R_z$ [kN]	$R_\eta$ [kN]	$R_\xi$ [kN]	$R_{\xi,lok}$ [kN]	$R_{z,lok}$ [kN]
1	SPLS 3_110 Ba All Cts	784	885	<b>4562</b>	-71	-1180	46	4724
2	SPLS 3_0 Ba All Cts	310	-514	<b>2205</b>	144	-583	10	2283
3	ULS 8 Ba	-292	-509	<b>2159</b>	-153	-567	14	2236
4	SPLS 3_70 Ah All Cts	-794	896	<b>4620</b>	72	-1195	46	4783

**Maximale trekbelasting**

Stijl	Combinatie	$R_x$ [kN]	$R_y$ [kN]	$R_z$ [kN]	$R_\eta$ [kN]	$R_\xi$ [kN]	$R_{\xi,lok}$ [kN]	$R_{z,lok}$ [kN]
1	ULS 8 Ba	-137	-354	<b>-1417</b>	154	347	-33	-1467
2	SPLS 3_0.9_70 Ah All Cts	-657	758	<b>-3962</b>	-72	1001	-64	-4103
3	SPLS 3_0.9_110 Ba All Cts	644	744	<b>-3890</b>	71	982	-64	-4028
4	SPLS 3_0.9_0 Ba All Cts	169	-374	<b>-1533</b>	-145	384	-28	-1588

**Maximale torsiebelasting (positief)**

Stijl	Combinatie	$R_x$ [kN]	$R_y$ [kN]	$R_z$ [kN]	$R_\eta$ [kN]	$R_\xi$ [kN]	$R_{\xi,lok}$ [kN]	$R_{z,lok}$ [kN]
1	SPLS 3_90 Ah Ct1	454	-133	831	<b>415</b>	-227	-4	860
2	SPLS 3_0.9_90 Ba Ct2	-297	-275	-82	<b>405</b>	15	-7	-85
3	SPLS 3_70 Ba Ct2	266	658	-2578	<b>277</b>	653	-40	-2669
4	SPLS 3_0.9_110 Ah Ct1	-439	810	3408	<b>262</b>	-884	32	3529

**Maximale torsiebelasting (negatief)**

Index	Combinatie	$R_x$ [kN]	$R_y$ [kN]	$R_z$ [kN]	$R_\eta$ [kN]	$R_\xi$ [kN]	$R_{\xi,lok}$ [kN]	$R_{z,lok}$ [kN]
1	SPLS 3_0.9_70 Ba Ct1	430	807	3367	<b>-266</b>	-875	30	3487
2	SPLS 3_110 Ah Ct2	-273	662	-2611	<b>-275</b>	661	-40	-2704
3	SPLS 3_0.9_90 Ah Ct2	288	-280	-37	<b>-402</b>	5	-5	-39
4	SPLS 3_90 Ba Ct1	-462	-127	870	<b>-416</b>	-237	-3	901

Project: RLL-TLB380  
 Masttype: HB+0\_c - 140gr  
 Mast: 1184

#### Combinatie Ftrek+Fhor

Stijl	Combinatie	R <sub>x</sub> [kN]	R <sub>y</sub> [kN]	R <sub>z</sub> [kN]	R <sub>η</sub> [kN]	R <sub>ξ</sub> [kN]	R <sub>ξ,lok</sub> [kN]	R <sub>z,lok</sub> [kN]
1	ULS 8 Ba	-137	-354	<b>-1417</b>	<b>154</b>	347	-33	-1467
2	SPLS 3_0.9_70 Ah All Cts	-657	758	<b>-3962</b>	<b>-72</b>	1001	-64	-4103
3	SPLS 3_0.9_110 Ba All Cts	644	744	<b>-3890</b>	<b>71</b>	982	-64	-4028
4	SPLS 3_0.9_0 Ba All Cts	169	-374	<b>-1533</b>	<b>-145</b>	384	-28	-1588

#### Permanente belasting

Stijl	Combinatie	R <sub>x</sub> [kN]	R <sub>y</sub> [kN]	R <sub>z</sub> [kN]	R <sub>η</sub> [kN]	R <sub>ξ</sub> [kN]	R <sub>ξ,lok</sub> [kN]	R <sub>z,lok</sub> [kN]
1	SLS 7	359	282	1717	55	-453	8	1778
2	SLS 7	-211	134	-1012	55	244	-27	-1048
3	SLS 7	211	134	-1012	-55	244	-27	-1048
4	SLS 7	-359	282	1717	-55	-453	8	1778

#### Omhullenden ongeacht stijl

Belasting	Combinatie	R <sub>x</sub> [kN]	R <sub>y</sub> [kN]	R <sub>z</sub> [kN]	R <sub>η</sub> [kN]	R <sub>ξ</sub> [kN]	R <sub>ξ,lok</sub> [kN]	R <sub>z,lok</sub> [kN]
Max. druk	SPLS 3_70 Ah All Cts	-794	896	<b>4620</b>	72	-1195	46	4783
Max. trek	SPLS 3_0.9_70 Ah All Cts	-657	758	<b>-3962</b>	-72	1001	-64	-4103
Max. pos. torsie	SPLS 3_90 Ah Ct1	454	-133	831	<b>415</b>	-227	-4	860
Max. neg. torsie	SPLS 3_90 Ba Ct1	-462	-127	870	<b>-416</b>	-237	-3	901
Comb. trek+torsie	SPLS 3_0.9_70 Ah All Cts	-657	758	<b>-3962</b>	<b>-72</b>	1001	-64	-4103

#### Maximale trekbelasting SLS

Stijl	Combinatie	R <sub>x</sub> [kN]	R <sub>y</sub> [kN]	R <sub>z</sub> [kN]	R <sub>η</sub> [kN]	R <sub>ξ</sub> [kN]	R <sub>ξ,lok</sub> [kN]	R <sub>z,lok</sub> [kN]
1	SPLS 3_0.9_90 Ah All Cts	-116	-350	<b>-1353</b>	166	329	-34	-1401
2	SPLS 3_0.9_70 Ah All Cts	-657	758	<b>-3962</b>	-72	1001	-64	-4103
3	SPLS 3_0.9_110 Ba All Cts	644	744	<b>-3890</b>	71	982	-64	-4028
4	SPLS 3_0.9_0 Ba All Cts	169	-374	<b>-1533</b>	-145	384	-28	-1588

#### Maximale drukbelasting SLS

Stijl	Combinatie	R <sub>x</sub> [kN]	R <sub>y</sub> [kN]	R <sub>z</sub> [kN]	R <sub>η</sub> [kN]	R <sub>ξ</sub> [kN]	R <sub>ξ,lok</sub> [kN]	R <sub>z,lok</sub> [kN]
1	SPLS 3_110 Ba All Cts	784	885	<b>4562</b>	-71	-1180	46	4724
2	SPLS 3_0.9_0 Ba All Cts	291	-495	<b>2112</b>	144	-555	12	2187
3	SPLS 3_70 Ah All Cts	-247	-488	<b>2001</b>	-170	-519	18	2072
4	SPLS 3_70 Ah All Cts	-794	896	<b>4620</b>	72	-1195	46	4783

Project: RLL-TLB380  
Masttype: HB+0\_c - 140gr  
Mast: 1184

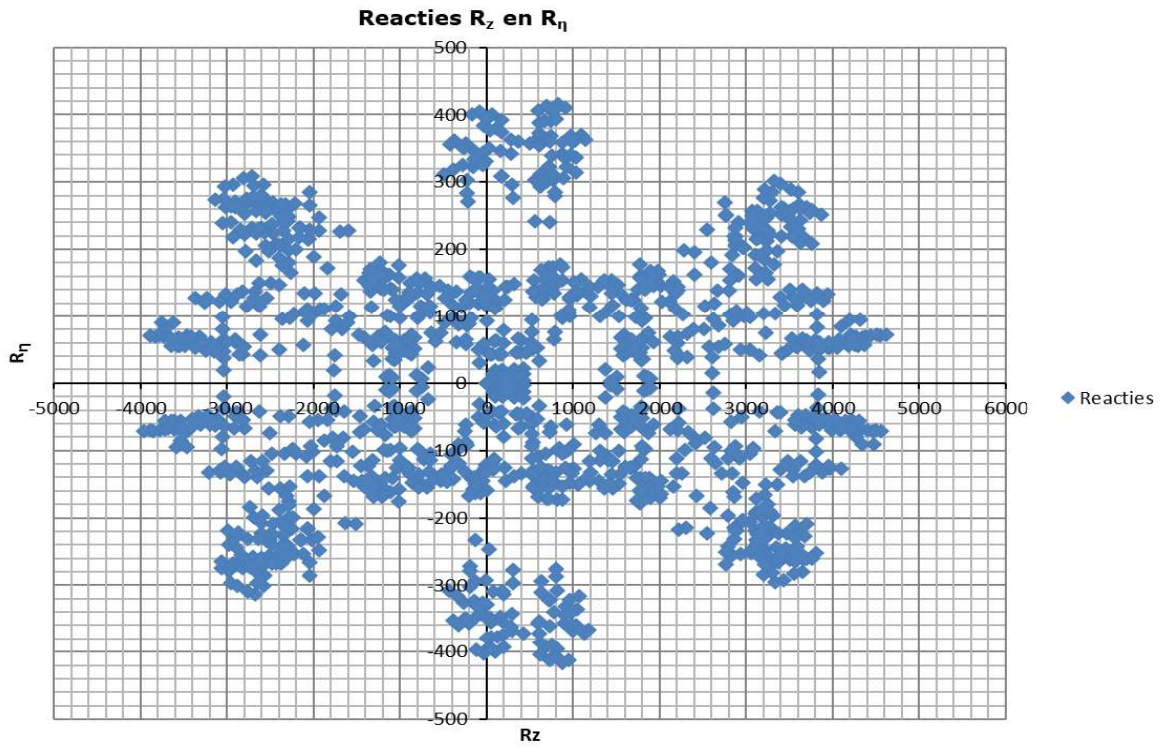



Project: RLL-TLB380  
 Tower: HB+0\_c - 160gr  
 Number: 1184

Auteur: TBR  
 Versie: v12.0

### Geleiderbelastingen

#### Algemeen

Benaming HB+0\_c - 160gr  
 Masttype Hoekmast  
 Aantal circuits 4  
 Configuratie 4-circuit-dubbel verticaal  
 Aantal bliksemgeleiders 2

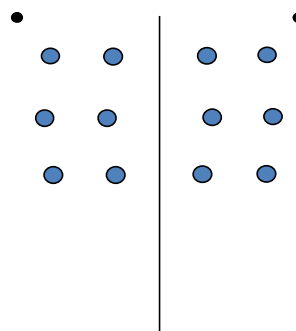

Configuratie geleiders

#### Uitgangspunten

Norm NEN-EN50341-2-15:2019  
 Gevolgklasse initieel CC2  
 Betrouwbaarheidsniveau initieel Nieuwbouw  
 Referentieperiode initieel 50 jaar  
 CC2  
 Betrouwbaarheidsniveau na aanpassing n.v.t.  
 50 jaar  
 Windgebied III  
 Windsnelheid (m/s) 24.5 m/s  
 Terreincategorie II  
 Reductiefactor  $C_{dir}$  1.00  
 IJsg gebied fasegeleider B  
 IJsg gebied bliksemgeleider A

#### Geleiders Back

Omschrijving	Spanning	Geleider Back	Bundel Ba	IJsg gebied	Toeslag gewicht	Toeslag diameter	Intrekwaarden $P_{back}$
Circuit 1	380 kV	AAAC-AL7 620	4	B	3 %	3 %	1800
Circuit 2	380 kV	AAAC-AL7 620	4	B	3 %	3 %	1800
Circuit 3	150 kV	AAAC-AL7 620	2	B	3 %	3 %	1800
Circuit 4	150 kV	AAAC-AL7 620	2	B	3 %	3 %	1800
Bliksemdraad 1		AACSR 241-AL3-39-A20SA	1	A	2 %	2 %	1800
Bliksemdraad 2		OPGW AFL-226/38	1	A	2 %	2 %	1800

#### Geleiders Ahead

Omschrijving	Spanning	Geleider Ahead	Bundel Ah	IJsg gebied	Toeslag gewicht	Toeslag diameter	Intrekwaarden $P_{ahead}$
Circuit 1	380 kV	AAAC-AL7 620	4	B	3 %	3 %	1800
Circuit 2	380 kV	AAAC-AL7 620	4	B	3 %	3 %	1800
Circuit 3	150 kV	AAAC-AL7 620	2	B	3 %	3 %	1800
Circuit 4	150 kV	AAAC-AL7 620	2	B	3 %	3 %	1800
Bliksemdraad 1		AACSR 241-AL3-39-A20SA	1	A	2 %	2 %	1800
Bliksemdraad 2		OPGW AFL-226/38	1	A	2 %	2 %	1800

#### Isolatoren (1)

Omschrijving	Ophanging	Gewicht [kN]	Lengte [m]	Windopp. [m <sup>2</sup> ]
Circuit 1	Afspanketting	3.00	6.50	1.10
Circuit 2	Afspanketting	3.00	6.50	1.10
Circuit 3	Afspanketting	2.00	4.50	0.80
Circuit 4	Afspanketting	2.00	4.50	0.80
Bliksemdraad 1	Afspanketting	0.10	0.20	0.10
Bliksemdraad 2	Afspanketting	0.10	0.20	0.10

1. Eigenschappen gelden voor geheel van de isolatorset

#### Ophanghoogte en positie in mast

Circuits	Aanduiding	Nummer	Ophanghoogte	Aangrijppunt	Positie in mast Horizontale afstand
Circuit 1	10	380ct1f1	48.0 m	48.0 m	-11.3 m
Circuit 1	11	380ct1f2	38.0 m	38.0 m	-14.8 m
Circuit 1	12	380ct1f3	28.5 m	28.5 m	-11.9 m
Circuit 2	40	380ct2f1	48.0 m	48.0 m	11.3 m
Circuit 2	41	380ct2f2	38.0 m	38.0 m	14.8 m
Circuit 2	42	380ct2f3	28.5 m	28.5 m	11.9 m
Circuit 3	20	150ct3f1	48.0 m	48.0 m	-4.5 m
Circuit 3	21	150ct3f2	38.0 m	38.0 m	-8.0 m
Circuit 3	22	150ct3f3	28.5 m	28.5 m	-5.1 m
Circuit 4	30	150ct4f1	48.0 m	48.0 m	4.5 m
Circuit 4	31	150ct4f2	38.0 m	38.0 m	8.0 m
Circuit 4	32	150ct4f3	28.5 m	28.5 m	5.1 m
Bliksemdraad 1	1	bl1	53.1 m	53.1 m	-17.0 m
Bliksemdraad 2	3	bl2	53.1 m	53.1 m	17.0 m

Project: RLL-TLB380  
 Tower: HB+0\_c - 160gr  
 Number: 1184

**Hoogteaanpassing naastgelegen masten** (aanpassing wind- en weight span)

	Back	Ahead	
Verhoging voor windbelasting	18.0 m	6.0 m	(positief: omhoog)
Verlaging voor verticale belasting	-9.0 m	-9.0 m	(negatief: omlaag, grotere weight span)
Verlaging:	Niet in 0,9EG-combinaties		

**Hoogteafwijking mastbeeld naastgelegen masten en richtingsverandering t.o.v. Lijnrichting**

Circuits	Aanduiding	Nummer	Hoogteverschil		Richtingsverandering	
			$\Delta h$ back	$\Delta h$ ahead	$\Delta y$ back	$\Delta y$ ahead
Circuit 1	10	380ct1f1	0.0	0.0 m	0.0	0.0 m
Circuit 1	11	380ct1f2	0.0	0.0 m	0.0	0.0 m
Circuit 1	12	380ct1f3	0.0	0.0 m	0.0	0.0 m
Circuit 2	40	380ct2f1	0.0	0.0 m	0.0	0.0 m
Circuit 2	41	380ct2f2	0.0	0.0 m	0.0	0.0 m
Circuit 2	42	380ct2f3	0.0	0.0 m	0.0	0.0 m
Circuit 3	20	150ct3f1	0.0	0.0 m	0.0	0.0 m
Circuit 3	21	150ct3f2	0.0	0.0 m	0.0	0.0 m
Circuit 3	22	150ct3f3	0.0	0.0 m	0.0	0.0 m
Circuit 4	30	150ct4f1	0.0	0.0 m	0.0	0.0 m
Circuit 4	31	150ct4f2	0.0	0.0 m	0.0	0.0 m
Circuit 4	32	150ct4f3	0.0	0.0 m	0.0	0.0 m
Bliksemdraad 1	1	bl1	0.0	0.0 m	0.0	0.0 m
Bliksemdraad 2	3	bl2	0.0	0.0 m	0.0	0.0 m

**Lijn- en mastgegevens**

	Back	Ahead
Ruling span $\sqrt{(\Sigma L^3)/\Sigma L}$	400.0	400.0 m
Lijnhoek $\beta$	160 °	
Rotatie mast t.o.v. bissectrice $\theta$	0 °	
Vaklengte	400	400 m
Hoogte onderkant mast t.o.v. maaiveld	0.5 m	
Beschouwde windrichtingen	$\alpha_1$	0 °
Windrichtingen volgens:	$\alpha_2$	45 °
Geleiderbelastingen	$\alpha_3$	90 °
	$\alpha_4$	135 °
	$\alpha_5$	80 °
	$\alpha_6$	100 °

Windrichtingen gelden t.o.v. hoofdrichting mastconstructie, niet t.o.v. bissectrice.

Windrichtingen en positieve richtingen belastingen

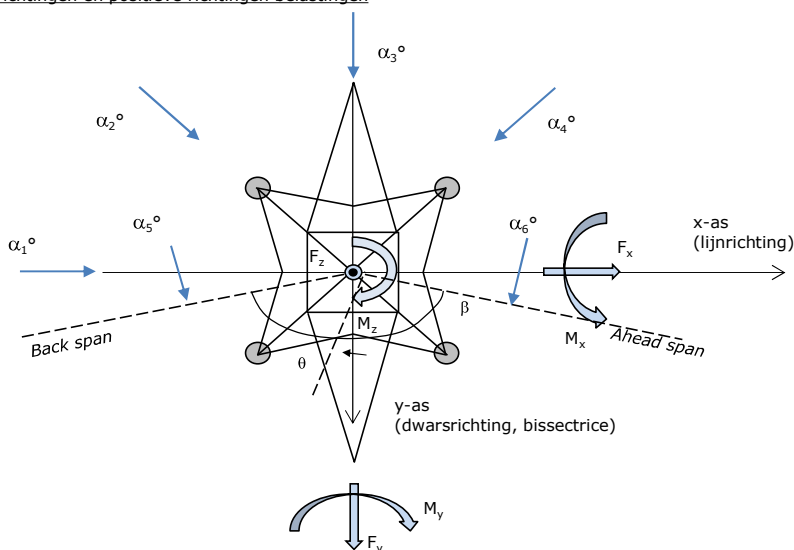

**Beschouwd aantal windrichtingen**

1a	6
3	6
4	1
6	1
Overig	1

Project: RLL-TLB380  
 Tower: HB+0\_c - 160gr  
 Number: 1184

### Geleiderafval

		SPLS - torsie		SPLS - Enkelzijdige trek		5a - geleiderbreuk	
		Aanw.	Afw.	Aanw.	Afw.	Aanw.	Afw.
Circuit 1	380ct1f1	1	0	1	0	1	0
Circuit 1	380ct1f2	1	0	1	0	1	0
Circuit 1	380ct1f3	1	0	1	0	1	0
Circuit 2	380ct2f1	0	1	1	0	1	0
Circuit 2	380ct2f2	0	1	1	0	1	0
Circuit 2	380ct2f3	0	1	1	0	1	0
Circuit 3	150ct3f1	1	0	1	0	1	0
Circuit 3	150ct3f2	1	0	1	0	1	0
Circuit 3	150ct3f3	1	0	1	0	1	0
Circuit 4	150ct4f1	0	1	1	0	1	0
Circuit 4	150ct4f2	0	1	1	0	1	0
Circuit 4	150ct4f3	0	1	1	0	1	0
Bliksemdraad 1	b11	1	0	1	0	1	0
Bliksemdraad 2	b12	0	1	1	0	1	0

### Belastingsituaties SPLS

Beschouwde situaties SPLS: 1 t/m 6, alle mogelijke situaties.

Principe belastingssituaties:

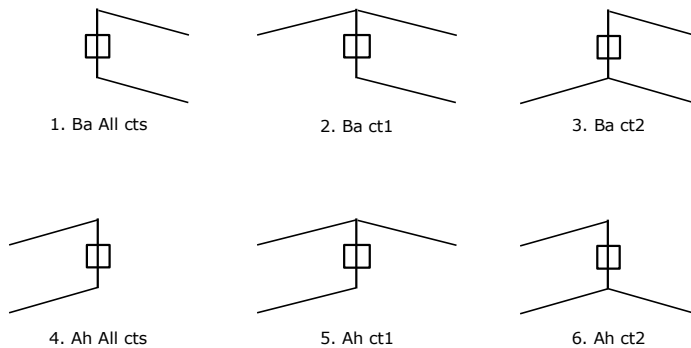

### Belastingsituaties 5a. Geleiderbreuk

Beschouwde situaties geleiderbreuk 5a: 1 en 2, alle mogelijke situaties.

Principe belastingssituaties:

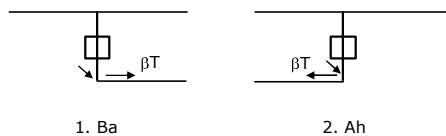



Project: RLL-TLB380  
 Tower: HB+0\_c - 160gr  
 Number: 1184

### Belastingsituaties 6. Bouw- en onderhoud

Onder 6a wordt de belasting door aanwezigheid lijnwagen of lijnfiets in combinatie met puntlast op traverse in rekening gebracht. Combinatie 6b bevat geen belastingen in geleider of op traverse. Deze combinatie is toegevoegd om te kunnen combineren met separate controle bordessen etc. De situaties worden in ULS en in iedere SPLS-situatie (in geval van hoekmast) toegepast.

	Fase	Bliksem
Lijnwagen	4.0 kN	2.0 kN
Puntlast op traverse	1.0 kN	1.0 kN

Beschouwde situaties bouw- en onderhoud 6a: 1 t/m 4, alle mogelijke situaties.

Aanwezigheid lijnwagen: Circuit, belasting tegelijk aanwezig in alle geleiders per circuit.

Principe belastingssituaties:

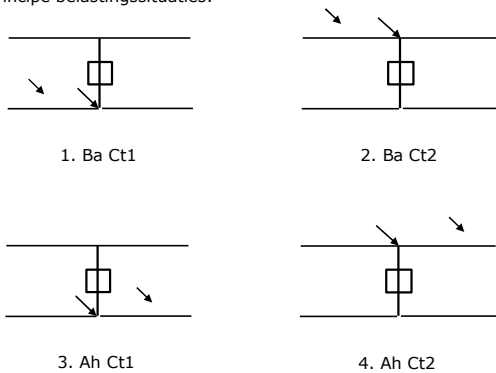

### Belastingsituaties 8. Lijndansen als statische belasting

Geleider		
Steunmast fase	0.866 W	1.5 W
Steunmast bliksem	1.5 EDS	1.5 W
Hoekmast fase en bliksem	1.5 EDS	1.5 W

Beschouwde situaties lijndansen 8: 1 en 2, alle mogelijke situaties.

Belasting tegelijk aanwezig in alle geleiders van het circuit.

Principe belastingssituaties:

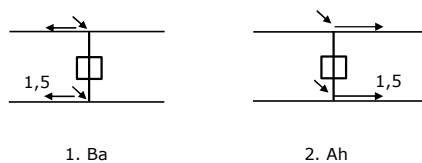

### Belastingcombinatie 8. Lijndansen als dynamische belasting

Alleen van toepassing op hoek- en eindmasten

Belasting bestaat uit EDS-trekbelasting in één van de geleiders aan één zijde van de mast

Door gebruiker via het belastingsspectrum van tabel 4.11/NL.1 om te zetten naar spanningspectrum

Project: RLL-TLB380  
 Tower: HB+0\_c - 160gr  
 Number: 1184

## Mastconstructie

### Eigenschappen

Masttype	Hoekmast	
Mastbenaming	HB+0_c - 160gr	
Voetplaat t.o.v. maaiveld	0.5 m	
Masthoogte t.o.v. voetplaat	53.1 m	
Gewicht mast	997.6 kN	
<i>Breedte en helling mast bij fundatie</i>		
	x-ri.	y-ri.
Pootsprei	11.76	11.76 m
Helling van de randstijl	0.190	0.190 -
Factor spatkracht	1.1	1.1 -

### Berekening windbelasting

Dynamische invloed $G_T$	1.00 ( <i>Masthoogte &lt; 60 m</i> )
Windbelasting overhoeks op mastlichaam evenredig met:	$(A1C1\sin^2(\phi)+A2C2\cos^2(\phi))$
Windbelasting overhoeks op traverse evenredig met:	$(A1C1\sin^2(\phi)+A2C2\cos^2(\phi))$
Vergroting wind overhoeks mastlichaam	$(1+0,2\sin^2(2\phi))$
Vergroting wind overhoeks traverse	$(1+0,2\sin^2(2\phi))$
Factor wind evenwijdig t.o.v. haaks op traverse	0.4

### Eigenschappen mastsecties langsrichting (vooraanzicht, yz-vlak)

Omschrijving	h [m]	b <sub>1</sub> [m]	b <sub>2</sub> [m]	Δh [m]	Δ <sub>x</sub> [m]	A <sub>0</sub> [m <sup>2</sup> ]	A <sub>1</sub> [m <sup>2</sup> ]	χ = A <sub>1</sub> /A <sub>0</sub> [-]	C <sub>t</sub>
Broekstuk	15.40	11.76	5.91	15.40	0.190	136.07	31.83	0.23	2.79
Eerste tussenstuk	22.20	5.91	5.23	6.80	0.050	37.88	13.54	0.36	2.34
Tweede tussenstuk	28.50	5.23	4.60	6.30	0.050	30.96	9.94	0.32	2.46
Bovenstuk 1	38.00	4.60	3.65	9.50	0.050	39.19	12.67	0.32	2.45
Bovenstuk 2	51.40	3.65	2.31	13.40	0.050	39.93	13.01	0.33	2.45
Topstuk	53.10	2.31		1.70		1.96	0.33	0.17	3.08
Ondertraverse	28.50	9.95		3.10		15.42	4.52	0.29	2.56
Middentraverse	38.00	13.30		3.20		21.28	6.53	0.31	2.51
Boventraverse	48.00	15.68		5.10		39.97	7.67	0.19	2.97

### Eigenschappen mastsecties dwarsrichting (zijaanzicht, xz-vlak)

Omschrijving	h [m]	b <sub>1</sub> [m]	b <sub>2</sub> [m]	Δh [m]	Δ <sub>x</sub> [m]	A <sub>0</sub> [m <sup>2</sup> ]	A <sub>1</sub> [m <sup>2</sup> ]	χ = A <sub>1</sub> /A <sub>0</sub> [-]	C <sub>t</sub>
Broekstuk	15.40	11.76	5.91	15.40	0.190	136.07	31.83	0.23	2.79
Eerste tussenstuk	22.20	5.91	5.23	6.80	0.050	37.88	13.54	0.36	2.34
Tweede tussenstuk	28.50	5.23	4.60	6.30	0.050	30.96	9.94	0.32	2.46
Bovenstuk 1	38.00	4.60	3.65	9.50	0.050	39.19	12.67	0.32	2.45
Bovenstuk 2	51.40	3.65	2.31	13.40	0.050	39.93	13.01	0.33	2.45
Topstuk	53.10	2.31		1.70		1.96	0.33	0.17	3.08
Ondertraverse	28.50	9.95		3.10		15.42	4.52	0.29	2.56
Middentraverse	38.00	13.30		3.20		21.28	6.53	0.31	2.51
Boventraverse	48.00	15.68		5.10		39.97	7.67	0.19	2.97

NB: oppervlakte traverse dwarsrichting van de tabel wordt in berekening gereduceerd.  
 NB: oppervlakte traverse per zijde, dus helft van totaal van twee traverses.

Project: RLL-TLB380  
 Tower: HB+0\_c - 160gr  
 Number: 1184

#### Windoppervlak feeders telecominstallaties

Onderdeel	A (m <sup>2</sup> /m)	Factor	Δh	A <sub>1</sub>
Broekstuk	0.14	0.71	15.4	1.5
Eerste tussenstuk	0.14	0.71	6.8	0.7
Tweede tussenstuk	0.14	0.71	6.3	0.6
Bovenstuk 1	0.14	0.71	9.5	0.9
Bovenstuk 2				

#### Invoer antennes

Omschrijving	A (m <sup>2</sup> )	h (m)	C <sub>i</sub> (m)
Antenne top			
Antenne o.t.	4.7	34.7	1.5

#### Belastingen mastsectie langsrichting (x-richting) per windrichting

Omschrijving	P <sub>w</sub> [kN/m <sup>2</sup> ]	F <sub>x1</sub> [kN]	F <sub>x2</sub> [kN]	F <sub>x3</sub> [kN]	F <sub>x4</sub> [kN]	h <sub>ef</sub> [m]	M <sub>y1</sub> [kNm]	M <sub>y2</sub> [kNm]	M <sub>y3</sub> [kNm]	M <sub>y4</sub> [kNm]
Broekstuk	0.70	62.2	52.8	0.0	-52.8	7.7	479.0	406.5	0.0	-406.5
Eerste tussenstuk	0.86	27.3	23.2	0.0	-23.2	18.8	513.6	435.8	0.0	-435.8
Tweede tussenstuk	0.94	23.0	19.5	0.0	-19.5	25.4	584.0	495.5	0.0	-495.5
Bovenstuk 1	1.02	31.8	27.0	0.0	-27.0	33.3	1056.2	896.2	0.0	-896.2
Bovenstuk 2	1.10	35.1	29.8	0.0	-29.8	44.7	1567.6	1330.2	0.0	-1330.2
Topstuk	1.15	1.2	1.0	0.0	-1.0	52.3	60.7	51.5	0.0	-51.5
Ondertraverse	0.98	22.8	13.5	0.0	-13.5	29.5	672.6	399.5	0.0	-399.5
Middentraverse	1.06	34.9	20.7	0.0	-20.7	39.1	1361.6	808.7	0.0	-808.7
Boventraverse	1.13	51.6	30.6	0.0	-30.6	49.7	2564.3	1523.1	0.0	-1523.1
<b>Totaal</b>		<b>289.8</b>	<b>218.1</b>	<b>0.0</b>	<b>-218.1</b>		<b>8859.6</b>	<b>6347.0</b>	<b>0.0</b>	<b>-6347.0</b>

#### Belastingen mastsectie dwarsrichting (y-richting) per windrichting

Omschrijving	P <sub>w</sub> [kN/m <sup>2</sup> ]	F <sub>y1</sub> [kN]	F <sub>y2</sub> [kN]	F <sub>y3</sub> [kN]	F <sub>y4</sub> [kN]	h <sub>ef</sub> [m]	M <sub>x1</sub> [kNm]	M <sub>x2</sub> [kNm]	M <sub>x3</sub> [kNm]	M <sub>x4</sub> [kNm]
Broekstuk	0.70	0.0	52.8	62.2	52.8	7.7	0.0	406.5	479.0	406.5
Eerste tussenstuk	0.86	0.0	23.2	27.3	23.2	18.8	0.0	435.8	513.6	435.8
Tweede tussenstuk	0.94	0.0	19.5	23.0	19.5	25.4	0.0	495.5	584.0	495.5
Bovenstuk 1	1.02	0.0	27.0	31.8	27.0	33.3	0.0	896.2	1056.2	896.2
Bovenstuk 2	1.10	0.0	29.8	35.1	29.8	44.7	0.0	1330.2	1567.6	1330.2
Topstuk	1.15	0.0	1.0	1.2	1.0	52.3	0.0	51.5	60.7	51.5
Ondertraverse	0.98	0.0	13.5	9.1	13.5	29.5	0.0	399.5	269.0	399.5
Middentraverse	1.06	0.0	20.7	13.9	20.7	39.1	0.0	808.7	544.6	808.7
Boventraverse	1.13	0.0	30.6	20.6	30.6	49.7	0.0	1523.1	1025.7	1523.1
<b>Totaal</b>		<b>0.0</b>	<b>218.1</b>	<b>224.3</b>	<b>218.1</b>		<b>0.0</b>	<b>6347.0</b>	<b>6100.5</b>	<b>6347.0</b>

#### Resulterende belastingen vanuit mastconstructie incl. antenne zonder geleiders niveau fundatie (kar. waarde)

Belasting / windrichting	F <sub>x</sub> [kN]	F <sub>y</sub> [kN]	F <sub>z</sub> [kN]	M <sub>x</sub> [kNm]	M <sub>y</sub> [kNm]	M <sub>z</sub> [kNm]
Permanente belasting	0	0	998	0	0	0
Windrichting 0°	297	0	0	0	9111	0
Windrichting 45°	223	223	0	6525	6525	0
Windrichting 90°	0	232	0	6352	0	0
Windrichting 135°	-223	223	0	6525	-6525	0

Project: RLL-TLB380  
 Tower: HB+0\_c - 160gr  
 Number: 1184

### Tussenresultaten geleiderbelastingen

#### Geleiders back

Circuit	Geleider	Diameter [mm]	A [mm <sup>2</sup> ]	G [N/m]	E [N/mm <sup>2</sup> ]	$\alpha T$ [-]
Circuit 1	AAAC-AL7 620	32.4	621.0	17.71	56000	2.30E-05
Circuit 2	AAAC-AL7 620	32.4	621.0	17.71	56000	2.30E-05
Circuit 3	AAAC-AL7 620	32.4	621.0	17.71	56000	2.30E-05
Circuit 4	AAAC-AL7 620	32.4	621.0	17.71	56000	2.30E-05
Bliksemdraad 1	AACSR 241-AL3-39-A20SA	21.8	281.0	9.38	70165	1.97E-05
Bliksemdraad 2	OPGW AFL-226/38	21.7	264.0	9.13	72000	1.98E-05

#### Geleiders ahead

Circuit	Geleider	Diameter [mm]	A [mm <sup>2</sup> ]	G [N/m]	E [N/mm <sup>2</sup> ]	$\alpha T$ [-]
Circuit 1	AAAC-AL7 620	32.4	621.0	17.71	56000	2.30E-05
Circuit 2	AAAC-AL7 620	32.4	621.0	17.71	56000	2.30E-05
Circuit 3	AAAC-AL7 620	32.4	621.0	17.71	56000	2.30E-05
Circuit 4	AAAC-AL7 620	32.4	621.0	17.71	56000	2.30E-05
Bliksemdraad 1	AACSR 241-AL3-39-A20SA	21.8	281.0	9.38	70165	1.97E-05
Bliksemdraad 2	OPGW AFL-226/38	21.7	264.0	9.13	72000	1.98E-05

#### Verticale belasting back

Circuit	Bundel [-]	Toeslag [%]	$W_{z,G}$ [N/m]	IJsgebied	Formule	$W_{z,ijs}$ [N/m]	$W_{z,ijs,bundel}$ [N/m]
Circuit 1	4	3	73.0	B	4+0,2d	10.5	41.9
Circuit 2	4	3	73.0	B	4+0,2d	10.5	41.9
Circuit 3	2	3	36.5	B	4+0,2d	10.5	21.0
Circuit 4	2	3	36.5	B	4+0,2d	10.5	21.0
Bliksemdraad 1	1	2	9.6	A	15+0,4d	23.7	23.7
Bliksemdraad 2	1	2	9.3	A	15+0,4d	23.7	23.7

#### Verticale belasting ahead

Circuit	Bundel [-]	Toeslag [%]	$W_{z,G}$ [N/m]	IJsgebied	Formule	$W_{z,ijs}$ [N/m]	$W_{z,ijs,bundel}$ [N/m]
Circuit 1	4	3	73.0	B	4+0,2d	10.5	41.9
Circuit 2	4	3	73.0	B	4+0,2d	10.5	41.9
Circuit 3	2	3	36.5	B	4+0,2d	10.5	21.0
Circuit 4	2	3	36.5	B	4+0,2d	10.5	21.0
Bliksemdraad 1	1	2	9.6	A	15+0,4d	23.7	23.7
Bliksemdraad 2	1	2	9.3	A	15+0,4d	23.7	23.7

#### Isolatoren

Geleider	$G_{isolator}$ [kN]	Aantal	$F_{v,iso}$ [kN]	Lengte [m]	Windopp. [m <sup>2</sup> ]	Windhoogte [m]	Stuwdruk [kN/m <sup>2</sup> ]	Vormfactor [-]	$F_{h,iso}$ [kN]
380ct1f1	3.00	1	3	6.5	1.1	48.50	1.13	1.2	1.49
380ct1f2	3.00	1	3	6.5	1.1	38.50	1.06	1.2	1.40
380ct1f3	3.00	1	3	6.5	1.1	29.00	0.98	1.2	1.29
380ct2f1	3.00	1	3	6.5	1.1	48.50	1.13	1.2	1.49
380ct2f2	3.00	1	3	6.5	1.1	38.50	1.06	1.2	1.40
380ct2f3	3.00	1	3	6.5	1.1	29.00	0.98	1.2	1.29
150ct3f1	2.00	1	2	4.5	0.8	48.50	1.13	1.2	1.08
150ct3f2	2.00	1	2	4.5	0.8	38.50	1.06	1.2	1.02
150ct3f3	2.00	1	2	4.5	0.8	29.00	0.98	1.2	0.94
150ct4f1	2.00	1	2	4.5	0.8	48.50	1.13	1.2	1.08
150ct4f2	2.00	1	2	4.5	0.8	38.50	1.06	1.2	1.02
150ct4f3	2.00	1	2	4.5	0.8	29.00	0.98	1.2	0.94
bl1	0.10	1	0.1	0.2	0.1	53.60	1.16	1.2	0.14
bl2	0.10	1	0.1	0.2	0.1	53.60	1.16	1.2	0.14

Project: RLL-TLB380  
 Tower: HB+0\_c - 160gr  
 Number: 1184

**Windbelasting back**

Geleider	hoogte		$G_{c\_dwars}$	$G_{c\_trek}$	$C_c$	$d_{toeslag}$	$W_y$	$W_{y,vak}$	$D_{jjs,toeslag}$	$W_{y,ijs}$	$W_{y,ijs,vak}$
	wind	Stuwdruk									
	[m]	[kN/m <sup>2</sup> ]	[-]	[-]	[-]	[mm]	[N/m]	[N/m]	[mm]	[N/m]	[N/m]
380ct1f1	50.1	1.14	0.62	0.68	0.96	33.37	89.8	98.8	51.8	174.5	191.9
380ct1f2	40.1	1.07	0.60	0.66	0.98	33.37	84.0	92.4	51.8	159.9	175.9
380ct1f3	30.6	0.99	0.58	0.64	1.00	33.37	77.1	84.9	51.8	143.2	157.6
380ct2f1	50.1	1.14	0.62	0.68	0.96	33.37	89.8	98.8	51.8	174.5	191.9
380ct2f2	40.1	1.07	0.60	0.66	0.98	33.37	84.0	92.4	51.8	159.9	175.9
380ct2f3	30.6	0.99	0.58	0.64	1.00	33.37	77.1	84.9	51.8	143.2	157.6
150ct3f1	50.1	1.14	0.62	0.68	0.96	33.37	44.9	49.4	51.8	87.3	95.9
150ct3f2	40.1	1.07	0.60	0.66	0.98	33.37	42.0	46.2	51.8	79.9	88.0
150ct3f3	30.6	0.99	0.58	0.64	1.00	33.37	38.6	42.4	51.8	71.6	78.8
150ct4f1	50.1	1.14	0.62	0.68	0.96	33.37	44.9	49.4	51.8	87.3	95.9
150ct4f2	40.1	1.07	0.60	0.66	0.98	33.37	42.0	46.2	51.8	79.9	88.0
150ct4f3	30.6	0.99	0.58	0.64	1.00	33.37	38.6	42.4	51.8	71.6	78.8
bl1	55.2	1.17	0.62	0.69	1.18	22.24	19.1	21.0	63.1	55.2	60.6
bl2	55.2	1.17	0.62	0.69	1.18	22.13	19.0	20.9	63.0	55.1	60.5

**Windbelasting ahead**

Geleider	hoogte		$G_{c\_dwars}$	$G_{c\_trek}$	$C_c$	$d_{toeslag}$	$W_y$	$W_{y,vak}$	$D_{jjs,toeslag}$	$W_{y,ijs}$	$W_{y,ijs,vak}$
	wind	Stuwdruk									
	[m]	[kN/m <sup>2</sup> ]	[-]	[-]	[-]	[mm]	[N/m]	[N/m]	[mm]	[N/m]	[N/m]
380ct1f1	44.1	1.10	0.61	0.67	0.97	33.37	86.5	95.1	51.8	166.0	182.6
380ct1f2	34.1	1.02	0.59	0.65	0.99	33.37	79.9	87.9	51.8	149.7	164.8
380ct1f3	24.6	0.93	0.56	0.62	1.02	33.37	71.7	78.9	51.8	130.4	143.6
380ct2f1	44.1	1.10	0.61	0.67	0.97	33.37	86.5	95.1	51.8	166.0	182.6
380ct2f2	34.1	1.02	0.59	0.65	0.99	33.37	79.9	87.9	51.8	149.7	164.8
380ct2f3	24.6	0.93	0.56	0.62	1.02	33.37	71.7	78.9	51.8	130.4	143.6
150ct3f1	44.1	1.10	0.61	0.67	0.97	33.37	43.2	47.6	51.8	83.0	91.3
150ct3f2	34.1	1.02	0.59	0.65	0.99	33.37	39.9	43.9	51.8	74.9	82.4
150ct3f3	24.6	0.93	0.56	0.62	1.02	33.37	35.8	39.5	51.8	65.2	71.8
150ct4f1	44.1	1.10	0.61	0.67	0.97	33.37	43.2	47.6	51.8	83.0	91.3
150ct4f2	34.1	1.02	0.59	0.65	0.99	33.37	39.9	43.9	51.8	74.9	82.4
150ct4f3	24.6	0.93	0.56	0.62	1.02	33.37	35.8	39.5	51.8	65.2	71.8
bl1	49.2	1.13	0.62	0.68	1.19	22.24	18.4	20.2	63.1	52.8	58.0
bl2	49.2	1.13	0.62	0.68	1.19	22.13	18.3	20.1	63.0	52.7	57.9

NB: belastingen  $w_v$  gelden voor bundel

Project: RLL-TLB380  
 Masttype: HB+0\_c - 160gr  
 Mast: 1184

Auteur: TBR  
 Versie: v12.0

### Geleiderbelastingen

#### Uitgangspunten

Betrouwbaarheidsniveau Nieuwbouw CC2  
 Referentieperiode 50 jaar

ULS (bezwijksterkte)		NEN-EN50341-2-15:2019							
Belastingsgeval	omschrijving	Temp °C	$\gamma_G$		$\gamma_Q$			$\gamma_a$ $A_k$	
			$G_{k,mast}$	$G_{k,geleider}$	$Q_{pk}$	$Q_{wk}$	$Q_{ik}$		
ULS 1a	Wind	10°	1.20	1.20	0.00	1.50	0.00	0.0	
ULS 1a_0,9	Wind 0,9Gk alleen mast	10°	0.90	1.20	0.00	1.50	0.00	0.0	
ULS 1a_0,9_0,9	Wind 0,9Gk ook geleider	10°	0.90	0.90	0.00	1.50	0.00	0.0	
ULS 3	Wind+ijs	-5°	1.20	1.20	0.00	0.45	1.50	0.0	
ULS 3_0,9	Wind+ijs 0,9	-5°	0.90	1.20	0.00	0.45	1.50	0.0	
ULS 4	Koude+wind	-20°	1.20	1.20	0.00	0.30	0.00	0.0	
ULS 4_0,9	Koude+wind 0,9	-20°	0.90	1.20	0.00	0.30	0.00	0.0	
ULS 5a	Torsiebelastingen	10°	1.00	1.00	1.00	0.00	0.00	1.0	
ULS 5b	Longitudinale belastingen	10°	1.00	1.00	0.00	0.00	0.00	1.0	
ULS 6	Bouw en onderhoud	5°	1.20	1.20	1.50	0.30	0.00	0.0	
ULS 6_0,9	Bouw en onderhoud	5°	1.20	1.20	0.00	0.30	0.00	0.0	
ULS 7	Permanent	10°	1.35	1.35	0.00	0.00	0.00	0.0	
ULS 8	Special	10°	1.00	1.00	0.00	0.00	0.00	1.0	
SPLS (Bezwijksterkte, enkel voor hoekmasten: afwezigheid geleiders)			$\gamma_G$		$\gamma_Q$			$A_k$	
			$G_k$	$G_k$	$Q_{pk}$	$Q_{wk}$	$Q_{ik}$		
SPLS 1a	Wind	10°	1.20	1.20	0.0	0.78	0.00	0.0	
SPLS 1a_0,9	Wind 0,9	10°	0.90	1.20	0.0	0.78	0.00	0.0	
SPLS 1a_0,9_0,9	Wind 0,9	10°	0.90	0.90	0.0	0.78	0.00	0.0	
SPLS 3	Wind+ijs	-5°	1.20	1.20	0.0	0.36	0.34	0.0	
SPLS 3_0,9	Wind+ijs 0,9	-5°	0.90	1.20	0.0	0.36	0.34	0.0	
SPLS 4	Koude+wind	-20°	1.20	1.20	0.0	0.24	0.00	0.0	
SPLS 4_0,9	Koude+wind 0,9	-20°	0.90	1.20	0.0	0.24	0.00	0.0	
SPLS 6	Bouw en onderhoud	5°	1.20	1.20	1.2	0.24	0.0	0.0	
SPLS 6_0,9	Bouw en onderhoud	5°	1.20	1.20	0.0	0.24	0.0	0.0	
SLS (controle van de vervormingen, vermoeiing, EDS)			$G_k$		$Q_{pk}$			$A_k$	
			$G_k$	$G_k$	$Q_{pk}$	$Q_{wk}$	$Q_{ik}$		
SLS 1a	Wind	10°	1.00	1.00	0.0	1.00	0.0	0.0	
SLS 3	Wind+ijs	-5°	1.00	1.00	0.0	0.30	1.00	0.0	
SLS 4	Wind	-20°	1.00	1.00	0.0	0.20	0.0	0.0	
SLS 6	Bouw en onderhoud	5°	1.00	1.00	0.0	0.20	0.0	0.0	
SLS 7	PB (EDS, geen wind)	10°	1.00	1.00	0.0	0.00	0.0	0.0	

Aantal windrichtingen 6  
 Aantal belastingcombinaties ULS 100  
 Aantal belastingcombinaties SPLS 246  
 Aantal belastingcombinaties SLS 15  
 Aantal knooplasten 12274

Project: RLL-TLB380  
 Masttype: HB+0\_c - 160gr  
 Mast: 1184

### Samenvattingstabellen geleiderbelastingen

In de onderstaande vier tabellen is weergegeven:

- De maximale geleiderbelasting in het globale assenstelsel, gesplitst in aandeel van back en ahead span
- De gecombineerde geleiderbelasting (Ba+Ah) in het globale assenstelsel met in het lokale assenstelsel de maximaal optredende trekkracht. Componenten Fx en Fy als absolute waarde
- De alledaagse (EDS) waarden van de gecombineerde geleiderbelastingen (Ba+Ah) met bijbehorende trekkrachten
- Controle op uplift, waar een negatieve waarde duidt op uplift

#### Maximale waarden voor back en ahead span

Geleider	Fx_ba [kN]	Fx_ah [kN]	Fy_ba [kN]	Fy_ah [kN]	Fz_ba [kN]	Fz_ah [kN]
bl1	-65.7	65.2	16.7	16.4	11.1	11.0
380ct1f1	-264.6	262.4	73.5	71.6	39.8	39.7
380ct1f2	-260.9	258.4	70.2	67.8	39.7	39.6
380ct1f3	-256.9	254.1	66.2	63.1	39.6	39.5
Post-isolato	0.0	0.0	0.0	0.0	0.0	
Post-isolato	0.0	0.0	0.0	0.0	0.0	
Post-isolato	0.0	0.0	0.0	0.0	0.0	
380ct2f1	-264.6	262.4	73.5	71.6	39.8	39.7
380ct2f2	-260.9	258.4	70.2	67.8	39.7	39.6
380ct2f3	-256.9	254.1	66.2	63.1	39.6	39.5
150ct3f1	-132.3	131.2	37.3	36.3	21.3	21.3
150ct3f2	-130.4	129.2	35.6	34.4	21.3	21.3
150ct3f3	-128.4	127.0	33.6	32.1	21.3	21.3
150ct4f1	-132.3	131.2	37.3	36.3	21.3	21.3
150ct4f2	-130.4	129.2	35.6	34.4	21.3	21.3
150ct4f3	-128.4	127.0	33.6	32.1	21.3	21.3
bl2	-64.8	64.3	16.5	16.2	11.0	10.9
Post-isolato	0.0	0.0	0.0	0.0	0.0	
Post-isolato	0.0	0.0	0.0	0.0	0.0	
Post-isolato	0.0	0.0	0.0	0.0	0.0	

#### Min. Weight span (m)

Weight spar Combinatie1

Geleider	SLS 1a	SLS 4	SLS 7
bl1	481.1	498.0	481.0
380ct1f1	481.1	496.4	481.0
380ct1f2	481.0	496.2	481.0
380ct1f3	481.0	495.8	481.0
Post-isolator 1			
Post-isolator 2			
Post-isolator 3			
380ct2f1	481.1	496.4	481.0
380ct2f2	481.0	496.2	481.0
380ct2f3	481.0	495.8	481.0
150ct3f1	481.1	496.4	481.0
150ct3f2	481.0	496.2	481.0
150ct3f3	481.0	495.8	481.0
150ct4f1	481.1	496.4	481.0
150ct4f2	481.0	496.2	481.0
150ct4f3	481.0	495.8	481.0
bl2	481.1	498.3	481.0
Post-isolator 4			
Post-isolator 5			
Post-isolator 6			

#### Max. Weight span (m)

Weight spar Combinatie1

Geleider	ULS 1a	ULS 3
bl1	575.0	464.1
380ct1f1	529.0	480.4
380ct1f2	524.0	479.3
380ct1f3	518.0	478.0
Post-isolator 1		
Post-isolator 2		
Post-isolator 3		
380ct2f1	529.0	480.4
380ct2f2	524.0	479.3
380ct2f3	518.0	478.0
150ct3f1	529.0	480.4
150ct3f2	524.0	479.3
150ct3f3	518.0	478.0
150ct4f1	529.0	480.4
150ct4f2	524.0	479.3
150ct4f3	518.0	478.0
bl2	577.5	463.7
Post-isolator 4		
Post-isolator 5		
Post-isolator 6		

Omhullende weight span over alle combinaties (incl. 0,9 combinaties)

#### Voor alle geleiders

Max. weight span	575.0 m
Min. weight span	93.3 m

#### Wind / Weight span verhouding

1.437 -
0.233 -

Project: RLL-TLB380  
 Masttype: HB+0\_c - 160gr  
 Mast: 1184

**Maximale waarden back+ahead span      Maximale waarden trekkracht geleider**

Geleider	Maximale waarden back+ahead span		Maximale waarden trekkracht geleider		
	Fx [kN]	Fy [kN]	Fz [kN]	Ft_ba [kN]	Ft_ah [kN]
bl1	38.7	32.7	11.1	-67.6	67.1
380ct1f1	205.8	141.9	39.8	-271.5	269.2
380ct1f2	201.9	135.0	39.7	-267.5	264.9
380ct1f3	197.6	126.6	39.6	-263.3	260.2
Post-isolato	4.2	4.2	6.8	0.0	
Post-isolato	3.2	3.2	4.7	0.0	
Post-isolato	4.9	4.9	6.8	0.0	
380ct2f1	205.8	141.9	39.8	-271.5	269.2
380ct2f2	201.9	135.0	39.7	-267.5	264.9
380ct2f3	197.6	126.6	39.6	-263.3	260.2
150ct3f1	108.3	71.9	21.3	-135.8	134.6
150ct3f2	108.2	68.5	21.3	-133.8	132.4
150ct3f3	108.1	64.3	21.3	-131.6	130.1
150ct4f1	108.3	71.9	21.3	-135.8	134.6
150ct4f2	108.2	68.5	21.3	-133.8	132.4
150ct4f3	108.1	64.3	21.3	-131.6	130.1
bl2	38.2	32.3	11.0	-66.7	66.1
Post-isolato	4.2	4.2	6.8	0.0	
Post-isolato	3.2	3.2	4.7	0.0	
Post-isolato	4.9	4.9	6.8	0.0	

**EDS-belastingen geleiders**

Geleider	EDS-belastingen geleiders		EDS-belastingen geleiders		
	Fx [kN]	Fy [kN]	Fz [kN]	Ft_ba [kN]	Ft_ah [kN]
bl1	17.0	3.0	2.4	-17.2	17.2
380ct1f1	129.3	22.8	20.5	-131.3	131.3
380ct1f2	129.3	22.8	20.5	-131.3	131.3
380ct1f3	129.3	22.8	20.5	-131.3	131.3
Post-isolato	0.0	0.0	5.0	0.0	
Post-isolato	0.0	0.0	3.5	0.0	
Post-isolato	0.0	0.0	5.0	0.0	
380ct2f1	129.3	22.8	20.5	-131.3	131.3
380ct2f2	129.3	22.8	20.5	-131.3	131.3
380ct2f3	129.3	22.8	20.5	-131.3	131.3
150ct3f1	64.7	11.4	10.8	-65.7	65.7
150ct3f2	64.7	11.4	10.8	-65.7	65.7
150ct3f3	64.7	11.4	10.8	-65.7	65.7
150ct4f1	64.7	11.4	10.8	-65.7	65.7
150ct4f2	64.7	11.4	10.8	-65.7	65.7
150ct4f3	64.7	11.4	10.8	-65.7	65.7
bl2	16.5	2.9	2.3	-16.8	16.8
Post-isolato	0.0	0.0	5.0	0.0	
Post-isolato	0.0	0.0	3.5	0.0	
Post-isolato	0.0	0.0	5.0	0.0	

**Controle uplift SLS-wind**

Combinatie: Geleider	Controle uplift SLS-wind	
	Fz_ba [kN]	Fz_ah [kN]
SLS 4		
bl1	0.0	0.0
380ct1f1	0.0	0.0
380ct1f2	0.0	0.0
380ct1f3	0.0	0.0
Post-isolato	0.0	
Post-isolato	0.0	
Post-isolato	0.0	
380ct2f1	0.0	0.0
380ct2f2	0.0	0.0
380ct2f3	0.0	0.0
150ct3f1	0.0	0.0
150ct3f2	0.0	0.0
150ct3f3	0.0	0.0
150ct4f1	0.0	0.0
150ct4f2	0.0	0.0
150ct4f3	0.0	0.0
bl2	0.0	0.0
Post-isolato	0.0	
Post-isolato	0.0	
Post-isolato	0.0	



Project: RLL-TLB380  
 Masttype: HB+0\_c - 160gr  
 Mast: 1184

**ULS-fundatiebelasting combinatie 1 en 3 wind haaks op de lijn of bissectrice en EDS, vanuit geleiders**

Combinatie	Combination	$F_x$ [kN]	$F_y$ [kN]	$F_z$ [kN]	$M_x$ [kNm]	$M_y$ [kNm]	$M_z$ [kNm]
ULS 1a_90		-59	1294	531	50644	-2205	0
ULS 1a_0.9_0		27	490	336	18910	1051	0
ULS 1a_0.9_0.9_90		-65	1252	193	49061	-2426	0
ULS 3_0		9	806	788	31398	343	0
SLS 7		0	422	412	16292	0	0

**ULS-fundatiebelasting combinatie 1 en 3 wind haaks op de lijn of bissectrice en EDS, totaal geleiders en mast**

Combinatie	$F_x$ [kN]	$F_y$ [kN]	$F_z$ [kN]	$M_x$ [kNm]	$M_y$ [kNm]	$M_z$ [kNm]
ULS 1a_90	-59	1641	1728	60173	-2205	0
ULS 1a_0.9_0.9_90	-65	1600	1091	58589	-2426	0
SLS 7	0	422	1410	16292	0	0

**Fundatiebelastingen, selectie belastingcombinaties op basis grootste waarde**

Combinatie	$F_x$ [kN]	$F_y$ [kN]	$F_z$ [kN]	$M_x$ [kNm]	$M_y$ [kNm]	$M_z$ [kNm]
ULS 1a_0.9_90	-59	1641	1183	<b>60174</b>	-2205	0
SPLS 3_80 Ah All Cts	-1877	493	1534	18223	<b>-73171</b>	9
SPLS 3_80 Ba Ct1	896	667	1649	26248	34599	<b>-10097</b>
SPLS 3_0.9_80 Ah All Cts	-1877	493	1096	<b>18224</b>	<b>-73171</b>	9

*Noot: grootste waarden kunnen in meerdere combinaties voorkomen, een combinatie is weergegeven.*

**Oplegreacties op fundering per randstijl**

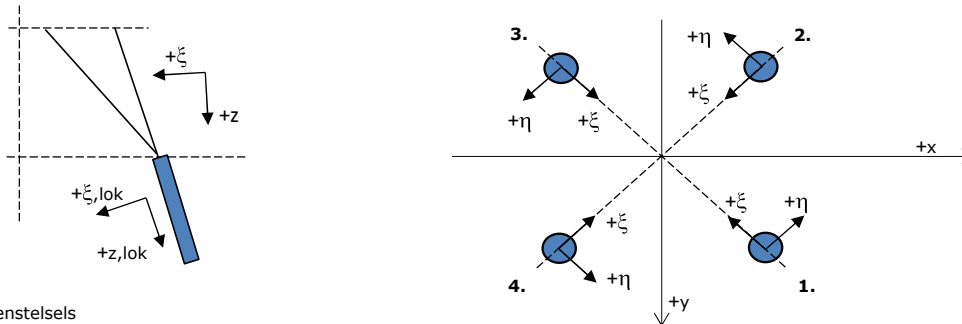

Assenstelsels

**Maximale drukbelasting**

Stijl	Combinatie	$R_x$ [kN]	$R_y$ [kN]	$R_z$ [kN]	$R_\eta$ [kN]	$R_\xi$ [kN]	$R_{\xi,lok}$ [kN]	$R_{z,lok}$ [kN]
1	SPLS 3_100 Ba All Cts	702	843	<b>4215</b>	-100	-1093	40	4365
2	ULS 8 Ah	418	-614	<b>2798</b>	138	-730	22	2897
3	ULS 8 Ba	-418	-614	<b>2798</b>	-138	-730	22	2897
4	SPLS 3_80 Ah All Cts	-711	854	<b>4269</b>	101	-1106	41	4420

**Maximale trekbelasting**

Stijl	Combinatie	$R_x$ [kN]	$R_y$ [kN]	$R_z$ [kN]	$R_\eta$ [kN]	$R_\xi$ [kN]	$R_{\xi,lok}$ [kN]	$R_{z,lok}$ [kN]
1	SPLS 3_0.9_90 Ah All Cts	-252	-471	<b>-2068</b>	154	511	-44	-2141
2	SPLS 3_0.9_80 Ah All Cts	-574	716	<b>-3611</b>	-100	912	-58	-3739
3	SPLS 3_0.9_100 Ba All Cts	562	702	<b>-3543</b>	99	894	-58	-3669
4	SPLS 3_0.9_0 Ba All Cts	283	-468	<b>-2111</b>	-131	532	-36	-2186

**Maximale torsiebelasting (positief)**

Stijl	Combinatie	$R_x$ [kN]	$R_y$ [kN]	$R_z$ [kN]	$R_\eta$ [kN]	$R_\xi$ [kN]	$R_{\xi,lok}$ [kN]	$R_{z,lok}$ [kN]
1	SPLS 3_90 Ah Ct1	295	-284	-28	<b>410</b>	-8	-16	-29
2	SPLS 3_0.9_90 Ba Ct2	-141	-424	762	<b>400</b>	-200	5	789
3	SPLS 3_90 Ba Ct2	144	612	-2126	<b>331</b>	534	-37	-2202
4	SPLS 3_0.9_90 Ah Ct1	-323	770	2987	<b>317</b>	-773	29	3093

**Maximale torsiebelasting (negatief)**

Index	Combinatie	$R_x$ [kN]	$R_y$ [kN]	$R_z$ [kN]	$R_\eta$ [kN]	$R_\xi$ [kN]	$R_{\xi,lok}$ [kN]	$R_{z,lok}$ [kN]
1	SPLS 3_0.9_90 Ba Ct1	309	762	2916	<b>-320</b>	-757	27	3020
2	SPLS 3_90 Ah Ct2	-157	622	-2191	<b>-329</b>	551	-38	-2269
3	SPLS 3_0.9_90 Ah Ct2	129	-431	821	<b>-396</b>	-213	7	851
4	SPLS 3_90 Ba Ct1	-306	-275	25	<b>-411</b>	-22	-15	26

Project: RLL-TLB380  
 Masttype: HB+0\_c - 160gr  
 Mast: 1184

#### Combinatie Ftrek+Fhor

Stijl	Combinatie	R <sub>x</sub> [kN]	R <sub>y</sub> [kN]	R <sub>z</sub> [kN]	R <sub>η</sub> [kN]	R <sub>ξ</sub> [kN]	R <sub>ξ,lok</sub> [kN]	R <sub>z,lok</sub> [kN]
1	SPLS 3_0.9_90 Ah All Cts	-252	-471	<b>-2068</b>	<b>154</b>	511	-44	-2141
2	SPLS 3_0.9_80 Ah All Cts	-574	716	<b>-3611</b>	<b>-100</b>	912	-58	-3739
3	SPLS 3_0.9_100 Ba All Cts	562	702	<b>-3543</b>	<b>99</b>	894	-58	-3669
4	SPLS 3_0.9_0 Ba All Cts	283	-468	<b>-2111</b>	<b>-131</b>	532	-36	-2186

#### Permanente belasting

Stijl	Combinatie	R <sub>x</sub> [kN]	R <sub>y</sub> [kN]	R <sub>z</sub> [kN]	R <sub>η</sub> [kN]	R <sub>ξ</sub> [kN]	R <sub>ξ,lok</sub> [kN]	R <sub>z,lok</sub> [kN]
1	SLS 7	218	179	1045	28	-281	0	1082
2	SLS 7	-71	32	-340	28	73	-19	-352
3	SLS 7	71	32	-340	-28	73	-19	-352
4	SLS 7	-218	179	1045	-28	-281	0	1082

#### Omhullenden ongeacht stijl

Belasting	Combinatie	R <sub>x</sub> [kN]	R <sub>y</sub> [kN]	R <sub>z</sub> [kN]	R <sub>η</sub> [kN]	R <sub>ξ</sub> [kN]	R <sub>ξ,lok</sub> [kN]	R <sub>z,lok</sub> [kN]
Max. druk	SPLS 3_80 Ah All Cts	-711	854	<b>4269</b>	101	-1106	41	4420
Max. trek	SPLS 3_0.9_80 Ah All Cts	-574	716	<b>-3611</b>	-100	912	-58	-3739
Max. pos. torsie	SPLS 3_90 Ah Ct1	295	-284	-28	<b>410</b>	-8	-16	-29
Max. neg. torsie	SPLS 3_90 Ba Ct1	-306	-275	25	<b>-411</b>	-22	-15	26
Comb. trek+torsie	SPLS 3_0.9_80 Ah All Cts	-574	716	<b>-3611</b>	<b>-100</b>	912	-58	-3739

#### Maximale trekbelasting SLS

Stijl	Combinatie	R <sub>x</sub> [kN]	R <sub>y</sub> [kN]	R <sub>z</sub> [kN]	R <sub>η</sub> [kN]	R <sub>ξ</sub> [kN]	R <sub>ξ,lok</sub> [kN]	R <sub>z,lok</sub> [kN]
1	SPLS 3_0.9_90 Ah All Cts	-252	-471	<b>-2068</b>	154	511	-44	-2141
2	SPLS 3_0.9_80 Ah All Cts	-574	716	<b>-3611</b>	-100	912	-58	-3739
3	SPLS 3_0.9_100 Ba All Cts	562	702	<b>-3543</b>	99	894	-58	-3669
4	SPLS 3_0.9_0 Ba All Cts	283	-468	<b>-2111</b>	-131	532	-36	-2186

#### Maximale drukbelasting SLS

Stijl	Combinatie	R <sub>x</sub> [kN]	R <sub>y</sub> [kN]	R <sub>z</sub> [kN]	R <sub>η</sub> [kN]	R <sub>ξ</sub> [kN]	R <sub>ξ,lok</sub> [kN]	R <sub>z,lok</sub> [kN]
1	SPLS 3_0.9_100 Ba All Cts	682	823	<b>4121</b>	-100	-1065	43	4267
2	SPLS 3_0.9_0 Ba All Cts	405	-589	<b>2690</b>	130	-703	20	2785
3	SPLS 3_80 Ah All Cts	-388	-607	<b>2719</b>	-155	-703	27	2816
4	SPLS 3_80 Ah All Cts	-711	854	<b>4269</b>	101	-1106	41	4420

Project: RLL-TLB380  
Masttype: HB+0\_c - 160gr  
Mast: 1184

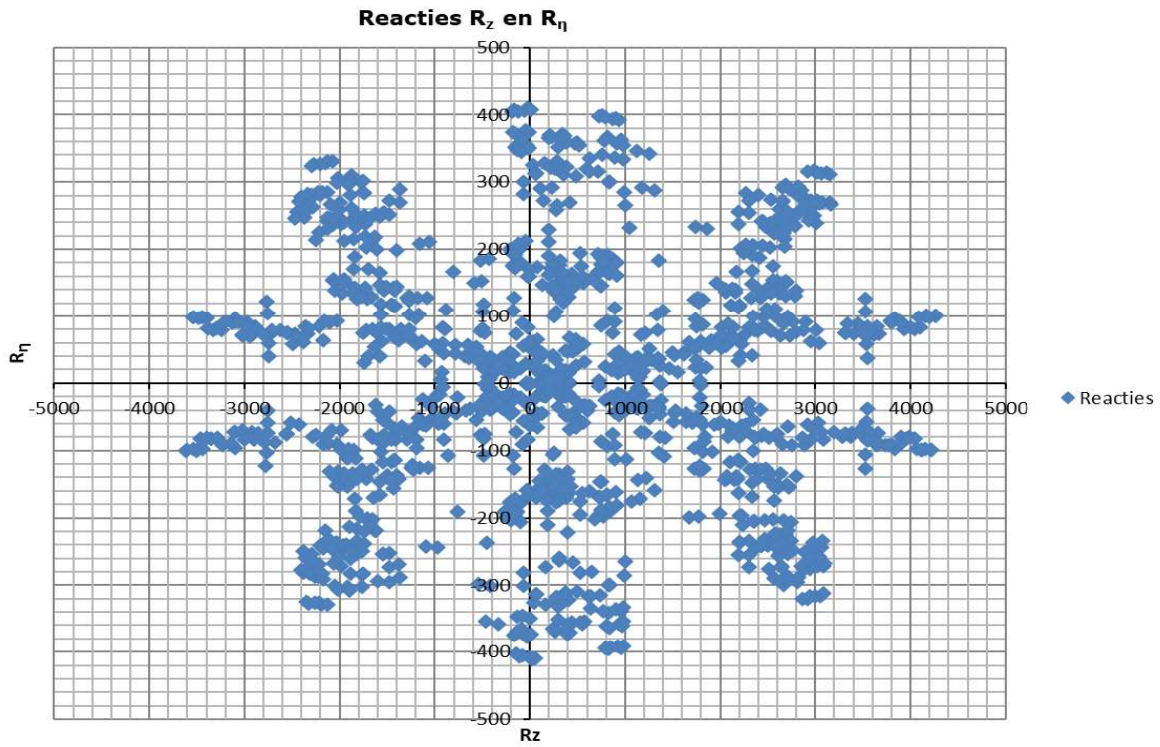



Project: RLL-TLB380  
Tower: HB+6\_c - 140gr  
Number: 1079

Auteur: TBR  
Versie: v12.0

### Geleiderbelastingen

#### Algemeen

Benaming HB+6\_c - 140gr  
Masttype Hoekmast  
Aantal circuits 4  
Configuratie 4-circuit-dubbel verticaal  
Aantal bliksemgeleiders 2

#### Uitgangspunten

Norm NEN-EN50341-2-15:2019  
Gevolgklasse initieel CC2  
Betrouwbaarheidsniveau initieel Nieuwbouw  
Referentieperiode initieel 50 jaar  
Betrouwbaarheidsniveau na aanpassing n.v.t.  
50 jaar  
Windgebied III  
Windsnelheid (m/s) 24.5 m/s  
Terreincategorie II  
Reductiefactor  $C_{dir}$  1.00  
IJSgebied fasegeleider B  
IJSgebied bliksemgeleider A

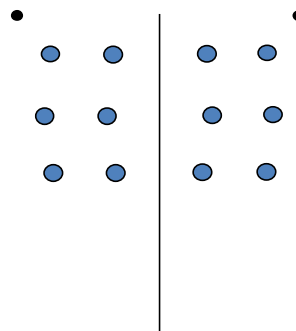

Configuratie geleiders

#### Geleiders Back

Omschrijving	Spanning	Geleider Back	Bundel Ba	IJSgebied	Toeslag gewicht	Toeslag diameter	Intrekwaarden $P_{back}$
Circuit 1	380 kV	AAAC-AL7 620	4	B	3 %	3 %	1800
Circuit 2	380 kV	AAAC-AL7 620	4	B	3 %	3 %	1800
Circuit 3	150 kV	AAAC-AL7 620	2	B	3 %	3 %	1800
Circuit 4	150 kV	AAAC-AL7 620	2	B	3 %	3 %	1800
Bliksemdraad 1		AACSR 241-AL3-39-A20SA	1	A	2 %	2 %	1800
Bliksemdraad 2		OPGW AFL-226/38	1	A	2 %	2 %	1800

#### Geleiders Ahead

Omschrijving	Spanning	Geleider Ahead	Bundel Ah	IJSgebied	Toeslag gewicht	Toeslag diameter	Intrekwaarden $P_{ahead}$
Circuit 1	380 kV	AAAC-AL7 620	4	B	3 %	3 %	1800
Circuit 2	380 kV	AAAC-AL7 620	4	B	3 %	3 %	1800
Circuit 3	150 kV	AAAC-AL7 620	2	B	3 %	3 %	1800
Circuit 4	150 kV	AAAC-AL7 620	2	B	3 %	3 %	1800
Bliksemdraad 1		AACSR 241-AL3-39-A20SA	1	A	2 %	2 %	1800
Bliksemdraad 2		OPGW AFL-226/38	1	A	2 %	2 %	1800

#### Isolatoren (1)

Omschrijving	Ophanging	Gewicht [kN]	Lengte [m]	Windopp. [m <sup>2</sup> ]
Circuit 1	Afspanketting	3.00	6.50	1.10
Circuit 2	Afspanketting	3.00	6.50	1.10
Circuit 3	Afspanketting	2.00	4.50	0.80
Circuit 4	Afspanketting	2.00	4.50	0.80
Bliksemdraad 1	Afspanketting	0.10	0.20	0.10
Bliksemdraad 2	Afspanketting	0.10	0.20	0.10

1. Eigenschappen gelden voor geheel van de isolatorset

#### Ophanghoogte en positie in mast

Circuits	Aanduiding	Nummer	Ophanghoogte	Aangrijppunt	Positie in mast Horizontale afstand
Circuit 1	10	380ct1f1	54.0 m	54.0 m	-11.3 m
Circuit 1	11	380ct1f2	44.0 m	44.0 m	-14.8 m
Circuit 1	12	380ct1f3	34.5 m	34.5 m	-11.9 m
Circuit 2	40	380ct2f1	54.0 m	54.0 m	11.3 m
Circuit 2	41	380ct2f2	44.0 m	44.0 m	14.8 m
Circuit 2	42	380ct2f3	34.5 m	34.5 m	11.9 m
Circuit 3	20	150ct3f1	54.0 m	54.0 m	-4.5 m
Circuit 3	21	150ct3f2	44.0 m	44.0 m	-8.0 m
Circuit 3	22	150ct3f3	34.5 m	34.5 m	-5.1 m
Circuit 4	30	150ct4f1	54.0 m	54.0 m	4.5 m
Circuit 4	31	150ct4f2	44.0 m	44.0 m	8.0 m
Circuit 4	32	150ct4f3	34.5 m	34.5 m	5.1 m
Bliksemdraad 1	1	bl1	59.1 m	59.1 m	-17.0 m
Bliksemdraad 2	3	bl2	59.1 m	59.1 m	17.0 m

Project: RLL-TLB380  
 Tower: HB+6\_c - 140gr  
 Number: 1079

**Hoogteaanpassing naastgelegen masten** (aanpassing wind- en weight span)

	Back	Ahead	
Verhoging voor windbelasting	12.0 m	6.0 m	(positief: omhoog)
Verlaging voor verticale belasting	-9.0 m	-9.0 m	(negatief: omlaag, grotere weight span)
Verlaging:	Niet in 0,9EG-combinaties		

**Hoogteafwijking mastbeeld naastgelegen masten en richtingsverandering t.o.v. Lijnrichting**

Circuits	Aanduiding	Nummer	Hoogteverschil		Richtingsverandering	
			$\Delta h$ back	$\Delta h$ ahead	$\Delta y$ back	$\Delta y$ ahead
Circuit 1	10	380ct1f1	0.0	0.0 m	0.0	0.0 m
Circuit 1	11	380ct1f2	0.0	0.0 m	0.0	0.0 m
Circuit 1	12	380ct1f3	0.0	0.0 m	0.0	0.0 m
Circuit 2	40	380ct2f1	0.0	0.0 m	0.0	0.0 m
Circuit 2	41	380ct2f2	0.0	0.0 m	0.0	0.0 m
Circuit 2	42	380ct2f3	0.0	0.0 m	0.0	0.0 m
Circuit 3	20	150ct3f1	0.0	0.0 m	0.0	0.0 m
Circuit 3	21	150ct3f2	0.0	0.0 m	0.0	0.0 m
Circuit 3	22	150ct3f3	0.0	0.0 m	0.0	0.0 m
Circuit 4	30	150ct4f1	0.0	0.0 m	0.0	0.0 m
Circuit 4	31	150ct4f2	0.0	0.0 m	0.0	0.0 m
Circuit 4	32	150ct4f3	0.0	0.0 m	0.0	0.0 m
Bliksemdraad 1	1	bl1	0.0	0.0 m	0.0	0.0 m
Bliksemdraad 2	3	bl2	0.0	0.0 m	0.0	0.0 m

**Lijn- en mastgegevens**

	Back	Ahead
Ruling span $\sqrt{(\Sigma L^3)/\Sigma L}$	400.0	400.0 m
Lijnhoek $\beta$	140 °	
Rotatie mast t.o.v. bissectrice $\theta$	0 °	
Vaklengte	400	400 m
Hoogte onderkant mast t.o.v. maaiveld	0.5 m	
Beschouwde windrichtingen	$\alpha_1$	0 °
Windrichtingen volgens:	$\alpha_2$	45 °
Geleiderbelastingen	$\alpha_3$	90 °
	$\alpha_4$	135 °
	$\alpha_5$	70 °
	$\alpha_6$	110 °

Windrichtingen gelden t.o.v. hoofdrichting mastconstructie, niet t.o.v. bissectrice.

Windrichtingen en positieve richtingen belastingen

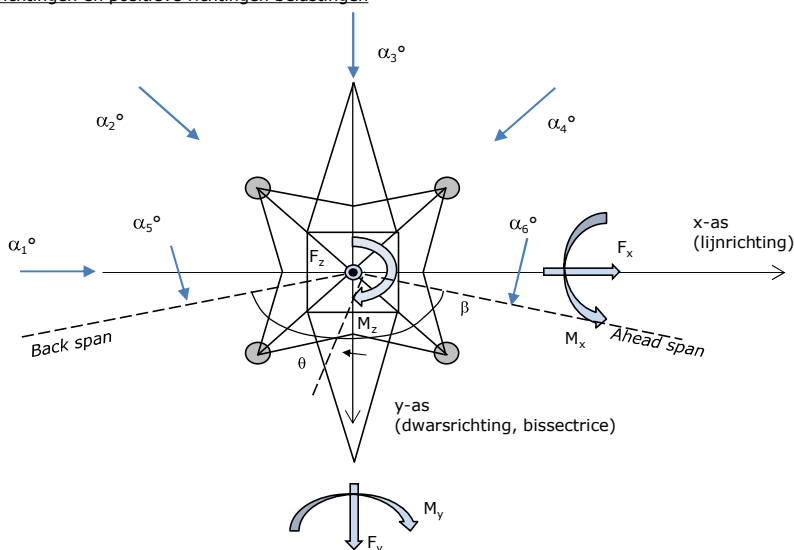

**Beschouwd aantal windrichtingen**

1a	6
3	6
4	1
6	1
Overig	1

Project: RLL-TLB380  
 Tower: HB+6\_c - 140gr  
 Number: 1079

### Geleiderafval

		SPLS - torsie		SPLS - Enkelzijdige trek		5a - geleiderbreuk	
		Aanw.	Afw.	Aanw.	Afw.	Aanw.	Afw.
Circuit 1	380ct1f1	1	0	1	0	1	0
Circuit 1	380ct1f2	1	0	1	0	1	0
Circuit 1	380ct1f3	1	0	1	0	1	0
Circuit 2	380ct2f1	0	1	1	0	1	0
Circuit 2	380ct2f2	0	1	1	0	1	0
Circuit 2	380ct2f3	0	1	1	0	1	0
Circuit 3	150ct3f1	1	0	1	0	1	0
Circuit 3	150ct3f2	1	0	1	0	1	0
Circuit 3	150ct3f3	1	0	1	0	1	0
Circuit 4	150ct4f1	0	1	1	0	1	0
Circuit 4	150ct4f2	0	1	1	0	1	0
Circuit 4	150ct4f3	0	1	1	0	1	0
Bliksemdraad 1	b11	1	0	1	0	1	0
Bliksemdraad 2	b12	0	1	1	0	1	0

### Belastingsituaties SPLS

Beschouwde situaties SPLS: 1 t/m 6, alle mogelijke situaties.

Principe belastingssituaties:

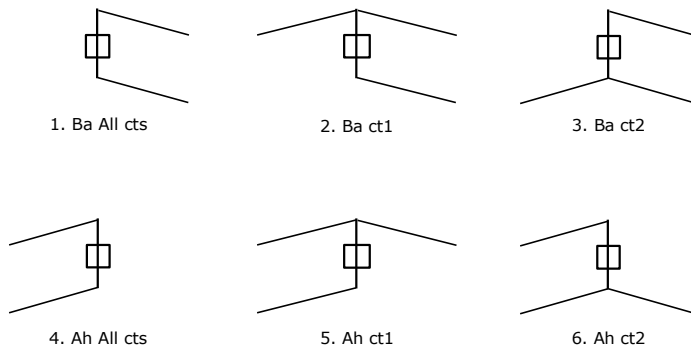

### Belastingsituaties 5a. Geleiderbreuk

Beschouwde situaties geleiderbreuk 5a: 1 en 2, alle mogelijke situaties.

Principe belastingssituaties:

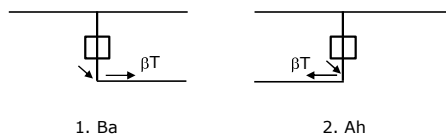

Project: RLL-TLB380  
 Tower: HB+6\_c - 140gr  
 Number: 1079

### Belastingsituaties 6. Bouw- en onderhoud

Onder 6a wordt de belasting door aanwezigheid lijnwagen of lijnfiets in combinatie met puntlast op traverse in rekening gebracht. Combinatie 6b bevat geen belastingen in geleider of op traverse. Deze combinatie is toegevoegd om te kunnen combineren met separate controle bordessen etc. De situaties worden in ULS en in iedere SPLS-situatie (in geval van hoekmast) toegepast.

	Fase	Bliksem
Lijnwagen	4.0 kN	2.0 kN
Puntlast op traverse	1.0 kN	1.0 kN

Beschouwde situaties bouw- en onderhoud 6a: 1 t/m 4, alle mogelijke situaties.

Aanwezigheid lijnwagen: Circuit, belasting tegelijk aanwezig in alle geleiders per circuit.

Principe belastingssituaties:

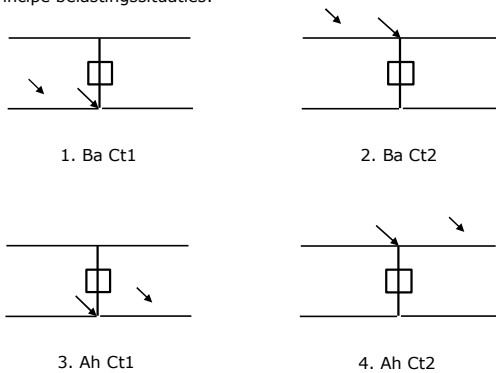

### Belastingsituaties 8. Lijndansen als statische belasting

Geleider		
Steunmast fase	0.866 W	1.5 W
Steunmast bliksem	1.5 EDS	1.5 W
Hoekmast fase en bliksem	1.5 EDS	1.5 W

Beschouwde situaties lijndansen 8: 1 en 2, alle mogelijke situaties.

Belasting tegelijk aanwezig in alle geleiders van het circuit.

Principe belastingssituaties:

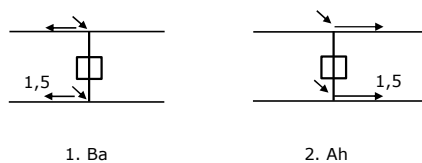

### Belastingcombinatie 8. Lijndansen als dynamische belasting

Alleen van toepassing op hoek- en eindmasten  
 Belasting bestaat uit EDS-trekbelasting in één van de geleiders aan één zijde van de mast  
 Door gebruiker via het belastingsspectrum van tabel 4.11/NL.1 om te zetten naar spanningspectrum



Project: RLL-TLB380  
 Tower: HB+6\_c - 140gr  
 Number: 1079

## Mastconstructie

### Eigenschappen

Masttype	Hoekmast	
Mastbenaming	HB+6_c - 140gr	
Voetplaat t.o.v. maaiveld	0.5 m	
Masthoogte t.o.v. voetplaat	59.1 m	
Gewicht mast	1139.9 kN	
<i>Breedte en helling mast bij fundatie</i>		
	x-ri.	y-ri.
Pootsprei	14.04	14.04 m
Helling van de randstijl	0.190	0.190 -
Factor spatkracht	1.1	1.1 -

### Berekening windbelasting

Dynamische invloed $G_T$	1.00 (Masthoogte < 60 m)
Windbelasting overhoeks op mastlichaam evenredig met:	$(A1C1\sin^2(\phi)+A2C2\cos^2(\phi))$
Windbelasting overhoeks op traverse evenredig met:	$(A1C1\sin^2(\phi)+A2C2\cos^2(\phi))$
Vergroting wind overhoeks mastlichaam	$(1+0,2\sin^2(2\phi))$
Vergroting wind overhoeks traverse	$(1+0,2\sin^2(2\phi))$
Factor wind evenwijdig t.o.v. haaks op traverse	0.4

### Eigenschappen mastsecties langsrichting (vooraanzicht, yz-vlak)

Omschrijving	h [m]	b <sub>1</sub> [m]	b <sub>2</sub> [m]	Δh [m]	Δ <sub>x</sub> [m]	A <sub>0</sub> [m <sup>2</sup> ]	A <sub>1</sub> [m <sup>2</sup> ]	χ = A <sub>1</sub> /A <sub>0</sub> [-]	C <sub>t</sub>
Broekstuk	21.40	14.04	5.91	21.40	0.190	213.49	49.54	0.23	2.79
Eerste tussenstuk	28.20	5.91	5.23	6.80	0.050	37.88	13.54	0.36	2.34
Tweede tussenstuk	34.50	5.23	4.60	6.30	0.050	30.96	9.94	0.32	2.46
Bovenstuk 1	44.00	4.60	3.65	9.50	0.050	39.19	12.67	0.32	2.45
Bovenstuk 2	57.40	3.65	2.31	13.40	0.050	39.93	13.01	0.33	2.45
Topstuk	59.10	2.31		1.70		1.96	0.33	0.17	3.08
Ondertraverse	34.50	9.95		3.10		15.42	4.52	0.29	2.56
Middentraverse	44.00	13.30		3.20		21.28	6.53	0.31	2.51
Boventraverse	54.00	15.68		5.10		39.97	7.67	0.19	2.97

### Eigenschappen mastsecties dwarsrichting (zijaanzicht, xz-vlak)

Omschrijving	h [m]	b <sub>1</sub> [m]	b <sub>2</sub> [m]	Δh [m]	Δ <sub>x</sub> [m]	A <sub>0</sub> [m <sup>2</sup> ]	A <sub>1</sub> [m <sup>2</sup> ]	χ = A <sub>1</sub> /A <sub>0</sub> [-]	C <sub>t</sub>
Broekstuk	21.40	14.04	5.91	21.40	0.190	213.49	49.54	0.23	2.79
Eerste tussenstuk	28.20	5.91	5.23	6.80	0.050	37.88	13.54	0.36	2.34
Tweede tussenstuk	34.50	5.23	4.60	6.30	0.050	30.96	9.94	0.32	2.46
Bovenstuk 1	44.00	4.60	3.65	9.50	0.050	39.19	12.67	0.32	2.45
Bovenstuk 2	57.40	3.65	2.31	13.40	0.050	39.93	13.01	0.33	2.45
Topstuk	59.10	2.31		1.70		1.96	0.33	0.17	3.08
Ondertraverse	34.50	9.95		3.10		15.42	4.52	0.29	2.56
Middentraverse	44.00	13.30		3.20		21.28	6.53	0.31	2.51
Boventraverse	54.00	15.68		5.10		39.97	7.67	0.19	2.97

NB: oppervlakte traverse dwarsrichting van de tabel wordt in berekening gereduceerd.  
 NB: oppervlakte traverse per zijde, dus helft van totaal van twee traveres.

Project: RLL-TLB380  
 Tower: HB+6\_c - 140gr  
 Number: 1079

#### Windoppervlak feeders telecominstallaties

Onderdeel	A (m <sup>2</sup> /m)	Factor	Δh	A <sub>1</sub>
Broekstuk	0.14	0.71	21.4	2.1
Eerste tussenstuk	0.14	0.71	6.8	0.7
Tweede tussenstuk	0.14	0.71	6.3	0.6
Bovenstuk 1	0.14	0.71	9.5	0.9
Bovenstuk 2				

#### Invoer antennes

Omschrijving	A (m <sup>2</sup> )	h (m)	C <sub>i</sub> (m)
Antenne top			
Antenne o.t.	4.7	40.7	1.5

#### Belastingen mastsectie langsrichting (x-richting) per windrichting

Omschrijving	P <sub>w</sub> [kN/m <sup>2</sup> ]	F <sub>x1</sub> [kN]	F <sub>x2</sub> [kN]	F <sub>x3</sub> [kN]	F <sub>x4</sub> [kN]	h <sub>ef</sub> [m]	M <sub>y1</sub> [kNm]	M <sub>y2</sub> [kNm]	M <sub>y3</sub> [kNm]	M <sub>y4</sub> [kNm]
Broekstuk	0.72	99.4	84.3	0.0	-84.3	10.7	1063.2	902.2	0.0	-902.2
Eerste tussenstuk	0.94	29.7	25.2	0.0	-25.2	24.8	736.1	624.6	0.0	-624.6
Tweede tussenstuk	1.00	24.5	20.8	0.0	-20.8	31.4	767.4	651.2	0.0	-651.2
Bovenstuk 1	1.07	33.2	28.2	0.0	-28.2	39.3	1303.9	1106.4	0.0	-1106.4
Bovenstuk 2	1.14	36.3	30.8	0.0	-30.8	50.7	1837.9	1559.5	0.0	-1559.5
Topstuk	1.18	1.2	1.0	0.0	-1.0	58.3	69.6	59.1	0.0	-59.1
Ondertraverse	1.04	24.0	14.2	0.0	-14.2	35.5	852.1	506.1	0.0	-506.1
Middentraverse	1.10	36.2	21.5	0.0	-21.5	45.1	1632.0	969.4	0.0	-969.4
Boventraverse	1.17	53.1	31.6	0.0	-31.6	55.7	2960.0	1758.2	0.0	-1758.2
<b>Totaal</b>		<b>337.5</b>	<b>257.6</b>	<b>0.0</b>	<b>-257.6</b>		<b>11222.3</b>	<b>8136.6</b>	<b>0.0</b>	<b>-8136.6</b>

#### Belastingen mastsectie dwarsrichting (y-richting) per windrichting

Omschrijving	P <sub>w</sub> [kN/m <sup>2</sup> ]	F <sub>y1</sub> [kN]	F <sub>y2</sub> [kN]	F <sub>y3</sub> [kN]	F <sub>y4</sub> [kN]	h <sub>ef</sub> [m]	M <sub>x1</sub> [kNm]	M <sub>x2</sub> [kNm]	M <sub>x3</sub> [kNm]	M <sub>x4</sub> [kNm]
Broekstuk	0.72	0.0	84.3	99.4	84.3	10.7	0.0	902.2	1063.2	902.2
Eerste tussenstuk	0.94	0.0	25.2	29.7	25.2	24.8	0.0	624.6	736.1	624.6
Tweede tussenstuk	1.00	0.0	20.8	24.5	20.8	31.4	0.0	651.2	767.4	651.2
Bovenstuk 1	1.07	0.0	28.2	33.2	28.2	39.3	0.0	1106.4	1303.9	1106.4
Bovenstuk 2	1.14	0.0	30.8	36.3	30.8	50.7	0.0	1559.5	1837.9	1559.5
Topstuk	1.18	0.0	1.0	1.2	1.0	58.3	0.0	59.1	69.6	59.1
Ondertraverse	1.04	0.0	14.2	9.6	14.2	35.5	0.0	506.1	340.9	506.1
Middentraverse	1.10	0.0	21.5	14.5	21.5	45.1	0.0	969.4	652.8	969.4
Boventraverse	1.17	0.0	31.6	21.3	31.6	55.7	0.0	1758.2	1184.0	1758.2
<b>Totaal</b>		<b>0.0</b>	<b>257.6</b>	<b>269.5</b>	<b>257.6</b>		<b>0.0</b>	<b>8136.6</b>	<b>7955.8</b>	<b>8136.6</b>

#### Resulterende belastingen vanuit mastconstructie incl. antenne zonder geleiders niveau fundatie (kar. waarde)

Belasting / windrichting	F <sub>x</sub> [kN]	F <sub>y</sub> [kN]	F <sub>z</sub> [kN]	M <sub>x</sub> [kNm]	M <sub>y</sub> [kNm]	M <sub>z</sub> [kNm]
Permanente belasting	0	0	1140	0	0	0
Windrichting 0°	345	0	0	0	11531	0
Windrichting 45°	263	263	0	8355	8355	0
Windrichting 90°	0	277	0	8264	0	0
Windrichting 135°	-263	263	0	8355	-8355	0

Project: RLL-TLB380  
 Tower: HB+6\_c - 140gr  
 Number: 1079

### Tussenresultaten geleiderbelastingen

#### Geleiders back

Circuit	Geleider	Diameter [mm]	A [mm <sup>2</sup> ]	G [N/m]	E [N/mm <sup>2</sup> ]	$\alpha T$ [-]
Circuit 1	AAAC-AL7 620	32.4	621.0	17.71	56000	2.30E-05
Circuit 2	AAAC-AL7 620	32.4	621.0	17.71	56000	2.30E-05
Circuit 3	AAAC-AL7 620	32.4	621.0	17.71	56000	2.30E-05
Circuit 4	AAAC-AL7 620	32.4	621.0	17.71	56000	2.30E-05
Bliksemdraad 1	AACSR 241-AL3-39-A20SA	21.8	281.0	9.38	70165	1.97E-05
Bliksemdraad 2	OPGW AFL-226/38	21.7	264.0	9.13	72000	1.98E-05

#### Geleiders ahead

Circuit	Geleider	Diameter [mm]	A [mm <sup>2</sup> ]	G [N/m]	E [N/mm <sup>2</sup> ]	$\alpha T$ [-]
Circuit 1	AAAC-AL7 620	32.4	621.0	17.71	56000	2.30E-05
Circuit 2	AAAC-AL7 620	32.4	621.0	17.71	56000	2.30E-05
Circuit 3	AAAC-AL7 620	32.4	621.0	17.71	56000	2.30E-05
Circuit 4	AAAC-AL7 620	32.4	621.0	17.71	56000	2.30E-05
Bliksemdraad 1	AACSR 241-AL3-39-A20SA	21.8	281.0	9.38	70165	1.97E-05
Bliksemdraad 2	OPGW AFL-226/38	21.7	264.0	9.13	72000	1.98E-05

#### Verticale belasting back

Circuit	Bundel [-]	Toeslag [%]	$W_{z,G}$ [N/m]	IJsgebied	Formule	$W_{z,ijs}$ [N/m]	$W_{z,ijs,bundel}$ [N/m]
Circuit 1	4	3	73.0	B	4+0,2d	10.5	41.9
Circuit 2	4	3	73.0	B	4+0,2d	10.5	41.9
Circuit 3	2	3	36.5	B	4+0,2d	10.5	21.0
Circuit 4	2	3	36.5	B	4+0,2d	10.5	21.0
Bliksemdraad 1	1	2	9.6	A	15+0,4d	23.7	23.7
Bliksemdraad 2	1	2	9.3	A	15+0,4d	23.7	23.7

#### Verticale belasting ahead

Circuit	Bundel [-]	Toeslag [%]	$W_{z,G}$ [N/m]	IJsgebied	Formule	$W_{z,ijs}$ [N/m]	$W_{z,ijs,bundel}$ [N/m]
Circuit 1	4	3	73.0	B	4+0,2d	10.5	41.9
Circuit 2	4	3	73.0	B	4+0,2d	10.5	41.9
Circuit 3	2	3	36.5	B	4+0,2d	10.5	21.0
Circuit 4	2	3	36.5	B	4+0,2d	10.5	21.0
Bliksemdraad 1	1	2	9.6	A	15+0,4d	23.7	23.7
Bliksemdraad 2	1	2	9.3	A	15+0,4d	23.7	23.7

#### Isolatoren

Geleider	$G_{isolator}$ [kN]	Aantal	$F_{v,iso}$ [kN]	Lengte [m]	Windopp. [m <sup>2</sup> ]	Windhoogte [m]	Stuwdruk [kN/m <sup>2</sup> ]	Vormfactor [-]	$F_{h,iso}$ [kN]
380ct1f1	3.00	1	3	6.5	1.1	54.50	1.16	1.2	1.53
380ct1f2	3.00	1	3	6.5	1.1	44.50	1.10	1.2	1.45
380ct1f3	3.00	1	3	6.5	1.1	35.00	1.03	1.2	1.36
380ct2f1	3.00	1	3	6.5	1.1	54.50	1.16	1.2	1.53
380ct2f2	3.00	1	3	6.5	1.1	44.50	1.10	1.2	1.45
380ct2f3	3.00	1	3	6.5	1.1	35.00	1.03	1.2	1.36
150ct3f1	2.00	1	2	4.5	0.8	54.50	1.16	1.2	1.11
150ct3f2	2.00	1	2	4.5	0.8	44.50	1.10	1.2	1.06
150ct3f3	2.00	1	2	4.5	0.8	35.00	1.03	1.2	0.99
150ct4f1	2.00	1	2	4.5	0.8	54.50	1.16	1.2	1.11
150ct4f2	2.00	1	2	4.5	0.8	44.50	1.10	1.2	1.06
150ct4f3	2.00	1	2	4.5	0.8	35.00	1.03	1.2	0.99
bl1	0.10	1	0.1	0.2	0.1	59.60	1.19	1.2	0.14
bl2	0.10	1	0.1	0.2	0.1	59.60	1.19	1.2	0.14

Project: RLL-TLB380  
 Tower: HB+6\_c - 140gr  
 Number: 1079

#### Windbelasting back

Geleider	hoogte		$G_{c\_dwars}$	$G_{c\_trek}$	$C_c$	$d_{toeslag}$	$w_y$	$w_{y,vak}$	$D_{ijs,toeslag}$	$w_{y,ijs}$	$w_{y,ijs,vak}$
	wind	Stuwdruk									
	[m]	[kN/m <sup>2</sup> ]	[-]	[-]	[-]	[mm]	[N/m]	[N/m]	[mm]	[N/m]	[N/m]
380ct1f1	53.1	1.15	0.62	0.68	0.95	33.37	91.4	100.4	51.8	178.5	196.2
380ct1f2	43.1	1.09	0.61	0.67	0.97	33.37	85.9	94.5	51.8	164.5	181.0
380ct1f3	33.6	1.02	0.59	0.65	1.00	33.37	79.5	87.5	51.8	148.8	163.8
380ct2f1	53.1	1.15	0.62	0.68	0.95	33.37	91.4	100.4	51.8	178.5	196.2
380ct2f2	43.1	1.09	0.61	0.67	0.97	33.37	85.9	94.5	51.8	164.5	181.0
380ct2f3	33.6	1.02	0.59	0.65	1.00	33.37	79.5	87.5	51.8	148.8	163.8
150ct3f1	53.1	1.15	0.62	0.68	0.95	33.37	45.7	50.2	51.8	89.2	98.1
150ct3f2	43.1	1.09	0.61	0.67	0.97	33.37	42.9	47.2	51.8	82.3	90.5
150ct3f3	33.6	1.02	0.59	0.65	1.00	33.37	39.7	43.7	51.8	74.4	81.9
150ct4f1	53.1	1.15	0.62	0.68	0.95	33.37	45.7	50.2	51.8	89.2	98.1
150ct4f2	43.1	1.09	0.61	0.67	0.97	33.37	42.9	47.2	51.8	82.3	90.5
150ct4f3	33.6	1.02	0.59	0.65	1.00	33.37	39.7	43.7	51.8	74.4	81.9
bl1	58.2	1.18	0.63	0.69	1.18	22.24	19.4	21.3	63.1	56.3	61.8
bl2	58.2	1.18	0.63	0.69	1.18	22.13	19.4	21.3	63.0	56.2	61.8

#### Windbelasting ahead

Geleider	hoogte		$G_{c\_dwars}$	$G_{c\_trek}$	$C_c$	$d_{toeslag}$	$w_y$	$w_{y,vak}$	$D_{ijs,toeslag}$	$w_{y,ijs}$	$w_{y,ijs,vak}$
	wind	Stuwdruk									
	[m]	[kN/m <sup>2</sup> ]	[-]	[-]	[-]	[mm]	[N/m]	[N/m]	[mm]	[N/m]	[N/m]
380ct1f1	50.1	1.14	0.62	0.68	0.96	33.37	89.8	98.8	51.8	174.5	191.9
380ct1f2	40.1	1.07	0.60	0.66	0.98	33.37	84.0	92.4	51.8	159.9	175.9
380ct1f3	30.6	0.99	0.58	0.64	1.00	33.37	77.1	84.9	51.8	143.2	157.6
380ct2f1	50.1	1.14	0.62	0.68	0.96	33.37	89.8	98.8	51.8	174.5	191.9
380ct2f2	40.1	1.07	0.60	0.66	0.98	33.37	84.0	92.4	51.8	159.9	175.9
380ct2f3	30.6	0.99	0.58	0.64	1.00	33.37	77.1	84.9	51.8	143.2	157.6
150ct3f1	50.1	1.14	0.62	0.68	0.96	33.37	44.9	49.4	51.8	87.3	95.9
150ct3f2	40.1	1.07	0.60	0.66	0.98	33.37	42.0	46.2	51.8	79.9	88.0
150ct3f3	30.6	0.99	0.58	0.64	1.00	33.37	38.6	42.4	51.8	71.6	78.8
150ct4f1	50.1	1.14	0.62	0.68	0.96	33.37	44.9	49.4	51.8	87.3	95.9
150ct4f2	40.1	1.07	0.60	0.66	0.98	33.37	42.0	46.2	51.8	79.9	88.0
150ct4f3	30.6	0.99	0.58	0.64	1.00	33.37	38.6	42.4	51.8	71.6	78.8
bl1	55.2	1.17	0.62	0.69	1.18	22.24	19.1	21.0	63.1	55.2	60.6
bl2	55.2	1.17	0.62	0.69	1.18	22.13	19.0	20.9	63.0	55.1	60.5

NB: belastingen  $w_v$  gelden voor bundel

Project: RLL-TLB380  
 Masttype: HB+6\_c - 140gr  
 Mast: 1079

Auteur: TBR  
 Versie: v12.0

### Geleiderbelastingen

#### Uitgangspunten

Betrouwbaarheidsniveau Nieuwbouw CC2  
 Referentieperiode 50 jaar

ULS (bezwijksterkte)		NEN-EN50341-2-15:2019							
Belastingsgeval	omschrijving	Temp °C	$\gamma_G$		$\gamma_Q$			$\gamma_a$ $A_k$	
			$G_{k,mast}$	$G_{k,geleider}$	$Q_{pk}$	$Q_{wk}$	$Q_{ik}$		
ULS 1a	Wind	10°	1.20	1.20	0.00	1.50	0.00	0.0	
ULS 1a_0,9	Wind 0,9Gk alleen mast	10°	0.90	1.20	0.00	1.50	0.00	0.0	
ULS 1a_0,9_0,9	Wind 0,9Gk ook geleider	10°	0.90	0.90	0.00	1.50	0.00	0.0	
ULS 3	Wind+ijs	-5°	1.20	1.20	0.00	0.45	1.50	0.0	
ULS 3_0,9	Wind+ijs 0,9	-5°	0.90	1.20	0.00	0.45	1.50	0.0	
ULS 4	Koude+wind	-20°	1.20	1.20	0.00	0.30	0.00	0.0	
ULS 4_0,9	Koude+wind 0,9	-20°	0.90	1.20	0.00	0.30	0.00	0.0	
ULS 5a	Torsiebelastingen	10°	1.00	1.00	1.00	0.00	0.00	1.0	
ULS 5b	Longitudinale belastingen	10°	1.00	1.00	0.00	0.00	0.00	1.0	
ULS 6	Bouw en onderhoud	5°	1.20	1.20	1.50	0.30	0.00	0.0	
ULS 6_0,9	Bouw en onderhoud	5°	1.20	1.20	0.00	0.30	0.00	0.0	
ULS 7	Permanent	10°	1.35	1.35	0.00	0.00	0.00	0.0	
ULS 8	Special	10°	1.00	1.00	0.00	0.00	0.00	1.0	
SPLS (Bezwijksterkte, enkel voor hoekmasten: afwezigheid geleiders)			$\gamma_G$		$\gamma_Q$				
			$G_k$	$G_k$	$Q_{pk}$	$Q_{wk}$	$Q_{ik}$	$A_k$	
SPLS 1a	Wind	10°	1.20	1.20	0.0	0.78	0.00	0.0	
SPLS 1a_0,9	Wind 0,9	10°	0.90	1.20	0.0	0.78	0.00	0.0	
SPLS 1a_0,9_0,9	Wind 0,9	10°	0.90	0.90	0.0	0.78	0.00	0.0	
SPLS 3	Wind+ijs	-5°	1.20	1.20	0.0	0.36	0.34	0.0	
SPLS 3_0,9	Wind+ijs 0,9	-5°	0.90	1.20	0.0	0.36	0.34	0.0	
SPLS 4	Koude+wind	-20°	1.20	1.20	0.0	0.24	0.00	0.0	
SPLS 4_0,9	Koude+wind 0,9	-20°	0.90	1.20	0.0	0.24	0.00	0.0	
SPLS 6	Bouw en onderhoud	5°	1.20	1.20	1.2	0.24	0.0	0.0	
SPLS 6_0,9	Bouw en onderhoud	5°	1.20	1.20	0.0	0.24	0.0	0.0	
SLS (controle van de vervormingen, vermoeiing, EDS)			$G_k$		$Q_{pk}$	$Q_{wk}$	$Q_{ik}$	$A_k$	
SLS 1a	Wind	10°	1.00	1.00	0.0	1.00	0.0	0.0	
SLS 3	Wind+ijs	-5°	1.00	1.00	0.0	0.30	1.00	0.0	
SLS 4	Wind	-20°	1.00	1.00	0.0	0.20	0.0	0.0	
SLS 6	Bouw en onderhoud	5°	1.00	1.00	0.0	0.20	0.0	0.0	
SLS 7	PB (EDS, geen wind)	10°	1.00	1.00	0.0	0.00	0.0	0.0	

Aantal windrichtingen 6  
 Aantal belastingcombinaties ULS 100  
 Aantal belastingcombinaties SPLS 246  
 Aantal belastingcombinaties SLS 15  
 Aantal knooplasten 12274

Project: RLL-TLB380  
 Masttype: HB+6\_c - 140gr  
 Mast: 1079

### Samenvattingstabellen geleiderbelastingen

In de onderstaande vier tabellen is weergegeven:

- De maximale geleiderbelasting in het globale assenstelsel, gesplitst in aandeel van back en ahead span
- De gecombineerde geleiderbelasting (Ba+Ah) in het globale assenstelsel met in het lokale assenstelsel de maximaal optredende trekkracht. Componenten Fx en Fy als absolute waarde
- De alledaagse (EDS) waarden van de gecombineerde geleiderbelastingen (Ba+Ah) met bijbehorende trekkrachten
- Controle op uplift, waar een negatieve waarde duidt op uplift

#### Maximale waarden voor back en ahead span

Geleider	Fx_ba [kN]	Fx_ah [kN]	Fy_ba [kN]	Fy_ah [kN]	Fz_ba [kN]	Fz_ah [kN]
bl1	-62.0	61.8	28.0	27.8	11.1	11.1
380ct1f1	-250.5	249.6	117.0	115.7	39.8	39.8
380ct1f2	-247.3	246.2	112.4	110.9	39.7	39.7
380ct1f3	-243.9	242.7	107.1	105.1	39.6	39.6
Post-isolato	0.0	0.0	0.0	0.0	0.0	
Post-isolato	0.0	0.0	0.0	0.0	0.0	
Post-isolato	0.0	0.0	0.0	0.0	0.0	
380ct2f1	-250.5	249.6	117.0	115.7	39.8	39.8
380ct2f2	-247.3	246.2	112.4	110.9	39.7	39.7
380ct2f3	-243.9	242.7	107.1	105.1	39.6	39.6
150ct3f1	-125.2	124.7	59.0	58.3	21.3	21.3
150ct3f2	-123.6	123.1	56.7	55.9	21.3	21.3
150ct3f3	-121.9	121.3	54.0	53.1	21.3	21.3
150ct4f1	-125.2	124.7	59.0	58.3	21.3	21.3
150ct4f2	-123.6	123.1	56.7	55.9	21.3	21.3
150ct4f3	-121.9	121.3	54.0	53.1	21.3	21.3
bl2	-61.1	60.9	27.7	27.5	11.0	11.0
Post-isolato	0.0	0.0	0.0	0.0	0.0	
Post-isolato	0.0	0.0	0.0	0.0	0.0	
Post-isolato	0.0	0.0	0.0	0.0	0.0	

#### Min. Weight span (m)

Weight spar Combinatie1

Geleider	SLS 1a	SLS 4	SLS 7
bl1	483.2	497.3	481.0
380ct1f1	481.8	496.2	481.0
380ct1f2	481.7	495.9	481.0
380ct1f3	481.6	495.7	481.0
Post-isolator 1			
Post-isolator 2			
Post-isolator 3			
380ct2f1	481.8	496.2	481.0
380ct2f2	481.7	495.9	481.0
380ct2f3	481.6	495.7	481.0
150ct3f1	481.8	496.2	481.0
150ct3f2	481.7	495.9	481.0
150ct3f3	481.6	495.7	481.0
150ct4f1	481.8	496.2	481.0
150ct4f2	481.7	495.9	481.0
150ct4f3	481.6	495.7	481.0
bl2	483.3	497.6	481.0
Post-isolator 4			
Post-isolator 5			
Post-isolator 6			

#### Max. Weight span (m)

Weight spar Combinatie1

Geleider	ULS 1a	ULS 3
bl1	567.6	463.4
380ct1f1	524.4	479.7
380ct1f2	520.3	478.7
380ct1f3	515.6	477.7
Post-isolator 1		
Post-isolator 2		
Post-isolator 3		
380ct2f1	524.4	479.7
380ct2f2	520.3	478.7
380ct2f3	515.6	477.7
150ct3f1	524.4	479.7
150ct3f2	520.3	478.7
150ct3f3	515.6	477.7
150ct4f1	524.4	479.7
150ct4f2	520.3	478.7
150ct4f3	515.6	477.7
bl2	570.0	463.0
Post-isolator 4		
Post-isolator 5		
Post-isolator 6		

Omhullende weight span over alle combinaties (incl. 0,9 combinaties)

Wind / Weight span verhouding	
Max. weight span	567.6 m
Min. weight span	181.6 m

Project: RLL-TLB380  
 Masttype: HB+6\_c - 140gr  
 Mast: 1079

**Maximale waarden back+ahead span      Maximale waarden trekkracht geleider**

Geleider	Fx	Fy	Fz	Ft_ba	Ft_ah
	[kN]	[kN]	[kN]	[kN]	[kN]
bl1	37.1	53.8	11.1	-67.8	67.6
380ct1f1	196.1	214.5	39.8	-272.7	271.5
380ct1f2	192.6	206.3	39.7	-268.8	267.5
380ct1f3	188.8	200.7	39.6	-264.7	263.3
Post-isolato	4.4	4.4	6.8	0.0	
Post-isolato	3.4	3.4	4.7	0.0	
Post-isolato	5.0	5.0	6.8	0.0	
380ct2f1	196.1	214.5	39.8	-272.7	271.5
380ct2f2	192.6	206.3	39.7	-268.8	267.5
380ct2f3	188.8	200.7	39.6	-264.7	263.3
150ct3f1	102.8	108.1	21.3	-136.3	135.8
150ct3f2	102.8	104.0	21.3	-134.4	133.8
150ct3f3	102.7	100.6	21.3	-132.3	131.6
150ct4f1	102.8	108.1	21.3	-136.3	135.8
150ct4f2	102.8	104.0	21.3	-134.4	133.8
150ct4f3	102.7	100.6	21.3	-132.3	131.6
bl2	36.6	53.1	11.0	-66.9	66.7
Post-isolato	4.4	4.4	6.8	0.0	
Post-isolato	3.4	3.4	4.7	0.0	
Post-isolato	5.0	5.0	6.8	0.0	

**EDS-belastingen geleiders**

Geleider	Fx	Fy	Fz	Ft_ba	Ft_ah
	[kN]	[kN]	[kN]	[kN]	[kN]
bl1	16.2	5.9	2.4	-17.2	17.2
380ct1f1	123.4	44.9	20.5	-131.3	131.3
380ct1f2	123.4	44.9	20.5	-131.3	131.3
380ct1f3	123.4	44.9	20.5	-131.3	131.3
Post-isolato	0.0	0.0	5.0	0.0	
Post-isolato	0.0	0.0	3.5	0.0	
Post-isolato	0.0	0.0	5.0	0.0	
380ct2f1	123.4	44.9	20.5	-131.3	131.3
380ct2f2	123.4	44.9	20.5	-131.3	131.3
380ct2f3	123.4	44.9	20.5	-131.3	131.3
150ct3f1	61.7	22.5	10.8	-65.7	65.7
150ct3f2	61.7	22.5	10.8	-65.7	65.7
150ct3f3	61.7	22.5	10.8	-65.7	65.7
150ct4f1	61.7	22.5	10.8	-65.7	65.7
150ct4f2	61.7	22.5	10.8	-65.7	65.7
150ct4f3	61.7	22.5	10.8	-65.7	65.7
bl2	15.7	5.7	2.3	-16.8	16.8
Post-isolato	0.0	0.0	5.0	0.0	
Post-isolato	0.0	0.0	3.5	0.0	
Post-isolato	0.0	0.0	5.0	0.0	

**Controle uplift SLS-wind**

Combinatie: Geleider	Fz_ba	Fz_ah
	[kN]	[kN]
SLS 4		
bl1	0.0	0.0
380ct1f1	0.0	0.0
380ct1f2	0.0	0.0
380ct1f3	0.0	0.0
Post-isolato	0.0	
Post-isolato	0.0	
Post-isolato	0.0	
380ct2f1	0.0	0.0
380ct2f2	0.0	0.0
380ct2f3	0.0	0.0
150ct3f1	0.0	0.0
150ct3f2	0.0	0.0
150ct3f3	0.0	0.0
150ct4f1	0.0	0.0
150ct4f2	0.0	0.0
150ct4f3	0.0	0.0
bl2	0.0	0.0
Post-isolato	0.0	
Post-isolato	0.0	
Post-isolato	0.0	

Project: RLL-TLB380  
 Masttype: HB+6\_c - 140gr  
 Mast: 1079

**ULS-fundatiebelasting combinatie 1 en 3 wind haaks op de lijn of bissectrice en EDS, vanuit geleiders**

Combinatie	Combination	$F_x$ [kN]	$F_y$ [kN]	$F_z$ [kN]	$M_x$ [kNm]	$M_y$ [kNm]	$M_z$ [kNm]
ULS 1a_90		-22	1961	528	88293	-954	0
ULS 1a_0.9_0		46	978	357	43644	2062	0
ULS 1a_0.9_0.9_90		-25	1874	229	84474	-1062	0
ULS 3_0		19	1590	789	71470	877	0
SLS 7		0	832	412	37082	0	0

**ULS-fundatiebelasting combinatie 1 en 3 wind haaks op de lijn of bissectrice en EDS, totaal geleiders en mast**

Combinatie	$F_x$ [kN]	$F_y$ [kN]	$F_z$ [kN]	$M_x$ [kNm]	$M_y$ [kNm]	$M_z$ [kNm]
ULS 1a_90	-22	2376	1895	100689	-954	0
ULS 1a_0.9_0.9_90	-25	2289	1255	96870	-1062	0
SLS 7	0	832	1552	37082	0	0

**Fundatiebelastingen, selectie belastingcombinaties op basis grootste waarde**

Combinatie	$F_x$ [kN]	$F_y$ [kN]	$F_z$ [kN]	$M_x$ [kNm]	$M_y$ [kNm]	$M_z$ [kNm]
ULS 1a_0.9_90	-22	2376	1348	<b>100690</b>	-954	0
SPLS 3_70 Ah All Cts	-1766	839	1705	36151	<b>-79835</b>	9
SPLS 3_70 Ba Ct1	798	1119	1818	49879	35023	<b>-9636</b>
SPLS 3_0.9_70 Ah All Cts	-1766	839	1253	<b>36151</b>	<b>-79835</b>	9

*Noot: grootste waarden kunnen in meerdere combinaties voorkomen, een combinatie is weergegeven.*

**Oplegreacties op fundering per randstijl**

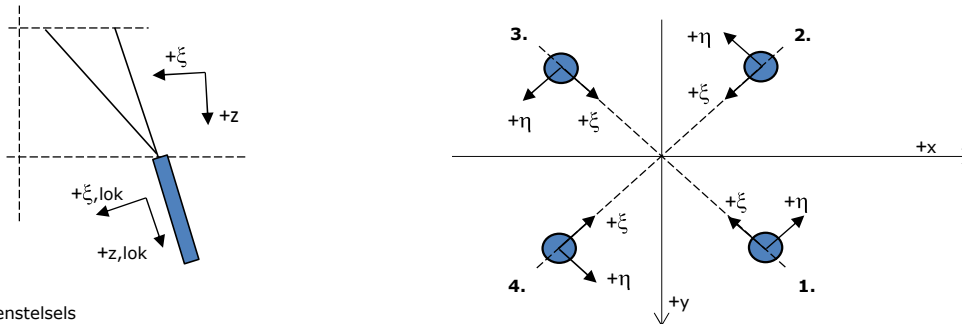

Assenstelsels

**Maximale drukbelasting**

Stijl	Combinatie	$R_x$ [kN]	$R_y$ [kN]	$R_z$ [kN]	$R_\eta$ [kN]	$R_\xi$ [kN]	$R_{\xi,lok}$ [kN]	$R_{z,lok}$ [kN]
1	SPLS 3_110 Ba All Cts	795	888	<b>4530</b>	-66	-1190	27	4691
2	SPLS 3_0 Ba All Cts	330	-507	<b>2203</b>	126	-592	0	2282
3	ULS 8 Ba	-307	-498	<b>2138</b>	-135	-569	6	2213
4	SPLS 3_70 Ah All Cts	-799	893	<b>4556</b>	66	-1197	27	4718

**Maximale trekbelasting**

Stijl	Combinatie	$R_x$ [kN]	$R_y$ [kN]	$R_z$ [kN]	$R_\eta$ [kN]	$R_\xi$ [kN]	$R_{\xi,lok}$ [kN]	$R_{z,lok}$ [kN]
1	ULS 8 Ba	-136	-328	<b>-1324</b>	135	328	-27	-1371
2	SPLS 3_0.9_70 Ah All Cts	-645	738	<b>-3817</b>	-66	978	-47	-3952
3	SPLS 3_0.9_110 Ba All Cts	639	732	<b>-3783</b>	65	969	-47	-3917
4	SPLS 3_0.9_0 Ba All Cts	173	-352	<b>-1457</b>	-126	371	-20	-1509

**Maximale torsiebelasting (positief)**

Stijl	Combinatie	$R_x$ [kN]	$R_y$ [kN]	$R_z$ [kN]	$R_\eta$ [kN]	$R_\xi$ [kN]	$R_{\xi,lok}$ [kN]	$R_{z,lok}$ [kN]
1	SPLS 3_90 Ah Ct1	425	-77	881	<b>355</b>	-246	-9	912
2	SPLS 3_0.9_90 Ba Ct2	-248	-239	-40	<b>345</b>	6	-4	-42
3	SPLS 3_70 Ba Ct2	286	617	-2480	<b>234</b>	638	-28	-2568
4	SPLS 3_0.9_110 Ah Ct1	-470	784	3359	<b>222</b>	-886	16	3478

**Maximale torsiebelasting (negatief)**

Stijl	Combinatie	$R_x$ [kN]	$R_y$ [kN]	$R_z$ [kN]	$R_\eta$ [kN]	$R_\xi$ [kN]	$R_{\xi,lok}$ [kN]	$R_{z,lok}$ [kN]
1	SPLS 3_0.9_70 Ba Ct1	466	782	3341	<b>-224</b>	-883	15	3460
2	SPLS 3_110 Ah Ct2	-289	619	-2496	<b>-233</b>	642	-28	-2584
3	SPLS 3_0.9_90 Ah Ct2	244	-242	-20	<b>-344</b>	2	-3	-21
4	SPLS 3_90 Ba Ct1	-428	-74	899	<b>-355</b>	-250	-9	931



Project: RLL-TLB380  
 Masttype: HB+6\_c - 140gr  
 Mast: 1079

#### Combinatie Ftrek+Fhor

Stijl	Combinatie	R <sub>x</sub> [kN]	R <sub>y</sub> [kN]	R <sub>z</sub> [kN]	R <sub>η</sub> [kN]	R <sub>ξ</sub> [kN]	R <sub>ξ,lok</sub> [kN]	R <sub>z,lok</sub> [kN]
1	ULS 8 Ba	-136	-328	<b>-1324</b>	<b>135</b>	328	-27	-1371
2	SPLS 3_0.9_70 Ah All Cts	-645	738	<b>-3817</b>	<b>-66</b>	978	-47	-3952
3	SPLS 3_0.9_110 Ba All Cts	639	732	<b>-3783</b>	<b>65</b>	969	-47	-3917
4	SPLS 3_0.9_0 Ba All Cts	173	-352	<b>-1457</b>	<b>-126</b>	371	-20	-1509

#### Permanente belasting

Stijl	Combinatie	R <sub>x</sub> [kN]	R <sub>y</sub> [kN]	R <sub>z</sub> [kN]	R <sub>η</sub> [kN]	R <sub>ξ</sub> [kN]	R <sub>ξ,lok</sub> [kN]	R <sub>z,lok</sub> [kN]
1	SLS 7	357	289	1708	48	-457	2	1769
2	SLS 7	-195	127	-932	48	227	-23	-965
3	SLS 7	195	127	-932	-48	227	-23	-965
4	SLS 7	-357	289	1708	-48	-457	2	1769

#### Omhullenden ongeacht stijl

Belasting	Combinatie	R <sub>x</sub> [kN]	R <sub>y</sub> [kN]	R <sub>z</sub> [kN]	R <sub>η</sub> [kN]	R <sub>ξ</sub> [kN]	R <sub>ξ,lok</sub> [kN]	R <sub>z,lok</sub> [kN]
Max. druk	SPLS 3_70 Ah All Cts	-799	893	<b>4556</b>	66	-1197	27	4718
Max. trek	SPLS 3_0.9_70 Ah All Cts	-645	738	<b>-3817</b>	-66	978	-47	-3952
Max. pos. torsie	SPLS 3_90 Ah Ct1	425	-77	881	<b>355</b>	-246	-9	912
Max. neg. torsie	SPLS 3_90 Ba Ct1	-428	-74	899	<b>-355</b>	-250	-9	931
Comb. trek+torsie	SPLS 3_0.9_70 Ah All Cts	-645	738	<b>-3817</b>	<b>-66</b>	978	-47	-3952

#### Maximale trekbelasting SLS

Stijl	Combinatie	R <sub>x</sub> [kN]	R <sub>y</sub> [kN]	R <sub>z</sub> [kN]	R <sub>η</sub> [kN]	R <sub>ξ</sub> [kN]	R <sub>ξ,lok</sub> [kN]	R <sub>z,lok</sub> [kN]
1	SPLS 3_0.9_90 Ah All Cts	-115	-319	<b>-1255</b>	145	307	-30	-1299
2	SPLS 3_0.9_70 Ah All Cts	-645	738	<b>-3817</b>	-66	978	-47	-3952
3	SPLS 3_0.9_110 Ba All Cts	639	732	<b>-3783</b>	65	969	-47	-3917
4	SPLS 3_0.9_0 Ba All Cts	173	-352	<b>-1457</b>	-126	371	-20	-1509

#### Maximale drukbelasting SLS

Stijl	Combinatie	R <sub>x</sub> [kN]	R <sub>y</sub> [kN]	R <sub>z</sub> [kN]	R <sub>η</sub> [kN]	R <sub>ξ</sub> [kN]	R <sub>ξ,lok</sub> [kN]	R <sub>z,lok</sub> [kN]
1	SPLS 3_110 Ba All Cts	795	888	<b>4530</b>	-66	-1190	27	4691
2	SPLS 3_0.9_0 Ba All Cts	308	-486	<b>2100</b>	126	-561	3	2175
3	SPLS 3_70 Ah All Cts	-262	-473	<b>1982</b>	-150	-520	13	2052
4	SPLS 3_70 Ah All Cts	-799	893	<b>4556</b>	66	-1197	27	4718

Project: RLL-TLB380  
Masttype: HB+6\_c - 140gr  
Mast: 1079

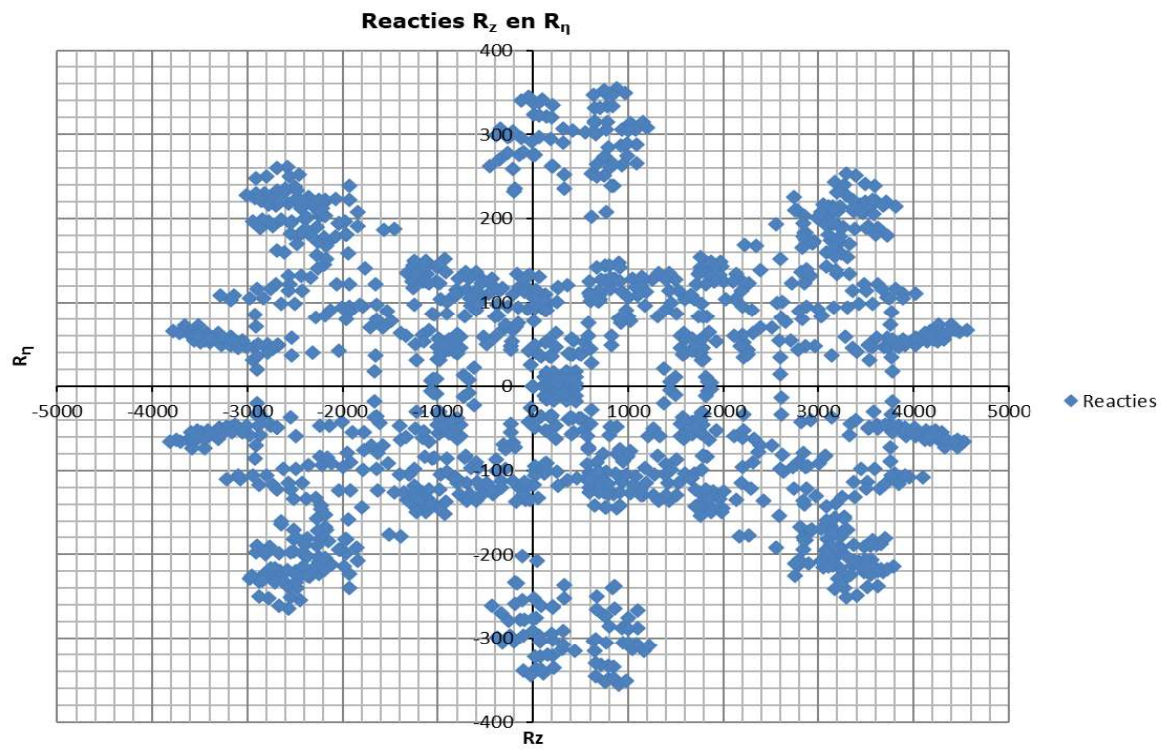



Project: RLL-TLB380  
 Tower: HB+6\_c - 160gr  
 Number: 1079

Auteur: TBR  
 Versie: v12.0

### Geleiderbelastingen

#### Algemeen

Benaming HB+6\_c - 160gr  
 Masttype Hoekmast  
 Aantal circuits 4  
 Configuratie 4-circuit-dubbel verticaal  
 Aantal bliksemgeleiders 2

#### Uitgangspunten

Norm NEN-EN50341-2-15:2019  
 Gevolgklasse initieel CC2  
 Betrouwbaarheidsniveau initieel Nieuwbouw  
 Referentieperiode initieel 50 jaar  
 Betrouwbaarheidsniveau na aanpassing n.v.t.  
 50 jaar  
 Windgebied III  
 Windsnelheid (m/s) 24.5 m/s  
 Terreincategorie II  
 Reductiefactor  $C_{dir}$  1.00  
 IJsg gebied fasegeleider B  
 IJsg gebied bliksemgeleider A

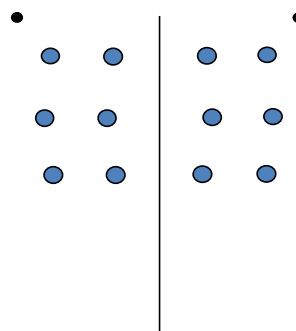

Configuratie geleiders

#### Geleiders Back

Omschrijving	Spanning	Geleider Back	Bundel Ba	IJsg gebied	Toeslag gewicht	Toeslag diameter	Intrekwaarden $P_{back}$
Circuit 1	380 kV	AAAC-AL7 620	4	B	3 %	3 %	1800
Circuit 2	380 kV	AAAC-AL7 620	4	B	3 %	3 %	1800
Circuit 3	150 kV	AAAC-AL7 620	2	B	3 %	3 %	1800
Circuit 4	150 kV	AAAC-AL7 620	2	B	3 %	3 %	1800
Bliksemdraad 1		AACSR 241-AL3-39-A20SA	1	A	2 %	2 %	1800
Bliksemdraad 2		OPGW AFL-226/38	1	A	2 %	2 %	1800

#### Geleiders Ahead

Omschrijving	Spanning	Geleider Ahead	Bundel Ah	IJsg gebied	Toeslag gewicht	Toeslag diameter	Intrekwaarden $P_{ahead}$
Circuit 1	380 kV	AAAC-AL7 620	4	B	3 %	3 %	1800
Circuit 2	380 kV	AAAC-AL7 620	4	B	3 %	3 %	1800
Circuit 3	150 kV	AAAC-AL7 620	2	B	3 %	3 %	1800
Circuit 4	150 kV	AAAC-AL7 620	2	B	3 %	3 %	1800
Bliksemdraad 1		AACSR 241-AL3-39-A20SA	1	A	2 %	2 %	1800
Bliksemdraad 2		OPGW AFL-226/38	1	A	2 %	2 %	1800

#### Isolatoren (1)

Omschrijving	Ophanging	Gewicht [kN]	Lengte [m]	Windopp. [m <sup>2</sup> ]
Circuit 1	Afspanketting	3.00	6.50	1.10
Circuit 2	Afspanketting	3.00	6.50	1.10
Circuit 3	Afspanketting	2.00	4.50	0.80
Circuit 4	Afspanketting	2.00	4.50	0.80
Bliksemdraad 1	Afspanketting	0.10	0.20	0.10
Bliksemdraad 2	Afspanketting	0.10	0.20	0.10

1. Eigenschappen gelden voor geheel van de isolatorset

#### Ophanghoogte en positie in mast

Circuits	Aanduiding	Nummer	Ophanghoogte	Aangrijppunt	Positie in mast Horizontale afstand
Circuit 1	10	380ct1f1	54.0 m	54.0 m	-11.3 m
Circuit 1	11	380ct1f2	44.0 m	44.0 m	-14.8 m
Circuit 1	12	380ct1f3	34.5 m	34.5 m	-11.9 m
Circuit 2	40	380ct2f1	54.0 m	54.0 m	11.3 m
Circuit 2	41	380ct2f2	44.0 m	44.0 m	14.8 m
Circuit 2	42	380ct2f3	34.5 m	34.5 m	11.9 m
Circuit 3	20	150ct3f1	54.0 m	54.0 m	-4.5 m
Circuit 3	21	150ct3f2	44.0 m	44.0 m	-8.0 m
Circuit 3	22	150ct3f3	34.5 m	34.5 m	-5.1 m
Circuit 4	30	150ct4f1	54.0 m	54.0 m	4.5 m
Circuit 4	31	150ct4f2	44.0 m	44.0 m	8.0 m
Circuit 4	32	150ct4f3	34.5 m	34.5 m	5.1 m
Bliksemdraad 1	1	bl1	59.1 m	59.1 m	-17.0 m
Bliksemdraad 2	3	bl2	59.1 m	59.1 m	17.0 m

Project: RLL-TLB380  
 Tower: HB+6\_c - 160gr  
 Number: 1079

**Hoogteaanpassing naastgelegen masten** (aanpassing wind- en weight span)

	Back	Ahead	
Verhoging voor windbelasting	12.0 m	6.0 m	(positief: omhoog)
Verlaging voor verticale belasting	-9.0 m	-9.0 m	(negatief: omlaag, grotere weight span)
Verlaging:	Niet in 0,9EG-combinaties		

**Hoogteafwijking mastbeeld naastgelegen masten en richtingsverandering t.o.v. Lijnrichting**

Circuits	Aanduiding	Nummer	Hoogteverschil		Richtingsverandering	
			$\Delta h$ back	$\Delta h$ ahead	$\Delta y$ back	$\Delta y$ ahead
Circuit 1	10	380ct1f1	0.0	0.0 m	0.0	0.0 m
Circuit 1	11	380ct1f2	0.0	0.0 m	0.0	0.0 m
Circuit 1	12	380ct1f3	0.0	0.0 m	0.0	0.0 m
Circuit 2	40	380ct2f1	0.0	0.0 m	0.0	0.0 m
Circuit 2	41	380ct2f2	0.0	0.0 m	0.0	0.0 m
Circuit 2	42	380ct2f3	0.0	0.0 m	0.0	0.0 m
Circuit 3	20	150ct3f1	0.0	0.0 m	0.0	0.0 m
Circuit 3	21	150ct3f2	0.0	0.0 m	0.0	0.0 m
Circuit 3	22	150ct3f3	0.0	0.0 m	0.0	0.0 m
Circuit 4	30	150ct4f1	0.0	0.0 m	0.0	0.0 m
Circuit 4	31	150ct4f2	0.0	0.0 m	0.0	0.0 m
Circuit 4	32	150ct4f3	0.0	0.0 m	0.0	0.0 m
Bliksemdraad 1	1	bl1	0.0	0.0 m	0.0	0.0 m
Bliksemdraad 2	3	bl2	0.0	0.0 m	0.0	0.0 m

**Lijn- en mastgegevens**

	Back	Ahead
Ruling span $\sqrt{(\Sigma L^3)/\Sigma L}$	400.0	400.0 m
Lijnhoek $\beta$	160 °	
Rotatie mast t.o.v. bissectrice $\theta$	0 °	
Vaklengte	400	400 m
Hoogte onderkant mast t.o.v. maaiveld	0.5 m	
Beschouwde windrichtingen	$\alpha_1$	0 °
Windrichtingen volgens:	$\alpha_2$	45 °
Geleiderbelastingen	$\alpha_3$	90 °
	$\alpha_4$	135 °
	$\alpha_5$	80 °
	$\alpha_6$	100 °

Windrichtingen gelden t.o.v. hoofdrichting mastconstructie, niet t.o.v. bissectrice.

Windrichtingen en positieve richtingen belastingen

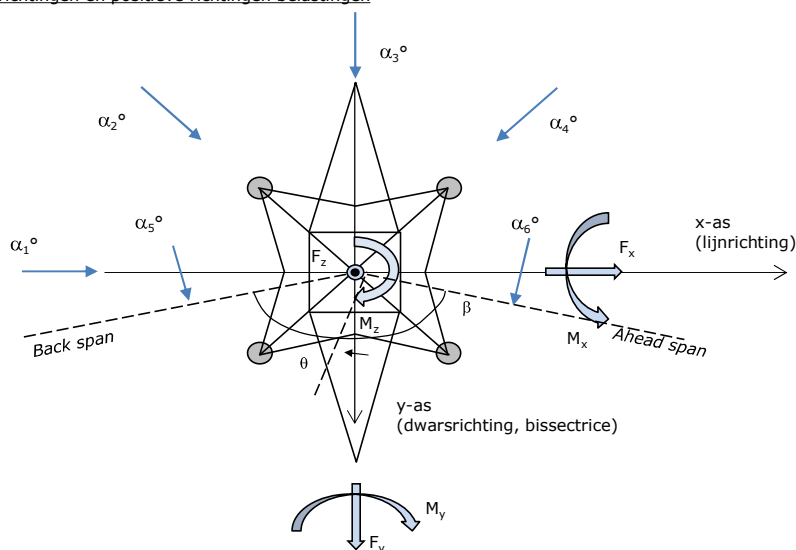

**Beschouwd aantal windrichtingen**

1a	6
3	6
4	1
6	1
Overig	1

Project: RLL-TLB380  
 Tower: HB+6\_c - 160gr  
 Number: 1079

### Geleiderafval

		SPLS - torsie		SPLS - Enkelzijdige trek		5a - geleiderbreuk	
		Aanw.	Afw.	Aanw.	Afw.	Aanw.	Afw.
Circuit 1	380ct1f1	1	0	1	0	1	0
Circuit 1	380ct1f2	1	0	1	0	1	0
Circuit 1	380ct1f3	1	0	1	0	1	0
Circuit 2	380ct2f1	0	1	1	0	1	0
Circuit 2	380ct2f2	0	1	1	0	1	0
Circuit 2	380ct2f3	0	1	1	0	1	0
Circuit 3	150ct3f1	1	0	1	0	1	0
Circuit 3	150ct3f2	1	0	1	0	1	0
Circuit 3	150ct3f3	1	0	1	0	1	0
Circuit 4	150ct4f1	0	1	1	0	1	0
Circuit 4	150ct4f2	0	1	1	0	1	0
Circuit 4	150ct4f3	0	1	1	0	1	0
Bliksemdraad 1	b11	1	0	1	0	1	0
Bliksemdraad 2	b12	0	1	1	0	1	0

### Belastingssituaties SPLS

Beschouwde situaties SPLS: 1 t/m 6, alle mogelijke situaties.

Principe belastingssituaties:

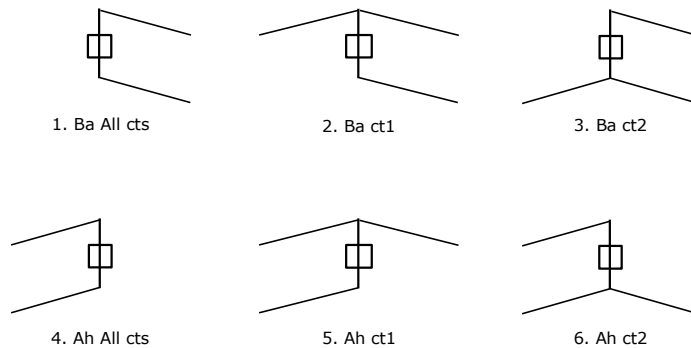

### Belastingssituaties 5a. Geleiderbreuk

Beschouwde situaties geleiderbreuk 5a: 1 en 2, alle mogelijke situaties.

Principe belastingssituaties:

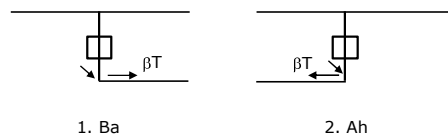

Project: RLL-TLB380  
 Tower: HB+6\_c - 160gr  
 Number: 1079

### Belastingsituaties 6. Bouw- en onderhoud

Onder 6a wordt de belasting door aanwezigheid lijnwagen of lijnfiets in combinatie met puntlast op traverse in rekening gebracht. Combinatie 6b bevat geen belastingen in geleider of op traverse. Deze combinatie is toegevoegd om te kunnen combineren met separate controle bordessen etc. De situaties worden in ULS en in iedere SPLS-situatie (in geval van hoekmast) toegepast.

	Fase	Bliksem
Lijnwagen	4.0 kN	2.0 kN
Puntlast op traverse	1.0 kN	1.0 kN

Beschouwde situaties bouw- en onderhoud 6a: 1 t/m 4, alle mogelijke situaties.

Aanwezigheid lijnwagen: Circuit, belasting tegelijk aanwezig in alle geleiders per circuit.

Principe belastingssituaties:

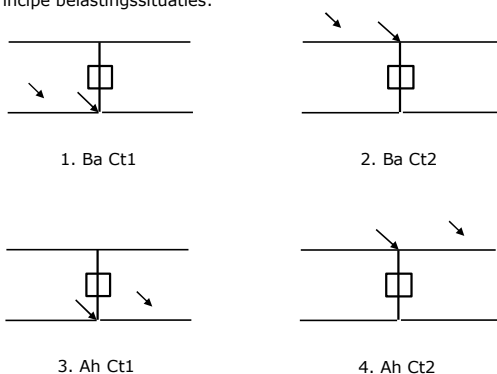

### Belastingsituaties 8. Lijndansen als statische belasting

Geleider		
Steunmast fase	0.866 W	1.5 W
Steunmast bliksem	1.5 EDS	1.5 W
Hoekmast fase en bliksem	1.5 EDS	1.5 W

Beschouwde situaties lijndansen 8: 1 en 2, alle mogelijke situaties.

Belasting tegelijk aanwezig in alle geleiders van het circuit.

Principe belastingssituaties:

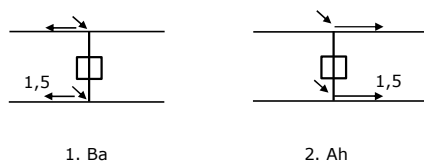

### Belastingcombinatie 8. Lijndansen als dynamische belasting

Alleen van toepassing op hoek- en eindmasten

Belasting bestaat uit EDS-trekbelasting in één van de geleiders aan één zijde van de mast

Door gebruiker via het belastingspectrum van tabel 4.11/NL.1 om te zetten naar spanningspectrum

Project: RLL-TLB380  
 Tower: HB+6\_c - 160gr  
 Number: 1079

## Mastconstructie

### Eigenschappen

Masttype	Hoekmast	
Mastbenaming	HB+6_c - 160gr	
Voetplaat t.o.v. maaiveld	0.5 m	
Masthoogte t.o.v. voetplaat	59.1 m	
Gewicht mast	1139.9 kN	
<i>Breedte en helling mast bij fundatie</i>		
	x-ri.	y-ri.
Pootsprei	14.04	14.04 m
Helling van de randstijl	0.190	0.190 -
Factor spatkracht	1.1	1.1 -

### Berekening windbelasting

Dynamische invloed $G_T$	1.00 ( <i>Masthoogte &lt; 60 m</i> )
Windbelasting overhoeks op mastlichaam evenredig met:	$(A1C1\sin^2(\phi)+A2C2\cos^2(\phi))$
Windbelasting overhoeks op traverse evenredig met:	$(A1C1\sin^2(\phi)+A2C2\cos^2(\phi))$
Vergroting wind overhoeks mastlichaam	$(1+0,2\sin^2(2\phi))$
Vergroting wind overhoeks traverse	$(1+0,2\sin^2(2\phi))$
Factor wind evenwijdig t.o.v. haaks op traverse	0.4

### Eigenschappen mastsecties langsrichting (vooraanzicht, yz-vlak)

Omschrijving	h [m]	b <sub>1</sub> [m]	b <sub>2</sub> [m]	Δh [m]	Δ <sub>x</sub> [m]	A <sub>0</sub> [m <sup>2</sup> ]	A <sub>1</sub> [m <sup>2</sup> ]	χ = A <sub>1</sub> /A <sub>0</sub> [-]	C <sub>t</sub>
Broekstuk	21.40	14.04	5.91	21.40	0.190	213.49	49.54	0.23	2.79
Eerste tussenstuk	28.20	5.91	5.23	6.80	0.050	37.88	13.54	0.36	2.34
Tweede tussenstuk	34.50	5.23	4.60	6.30	0.050	30.96	9.94	0.32	2.46
Bovenstuk 1	44.00	4.60	3.65	9.50	0.050	39.19	12.67	0.32	2.45
Bovenstuk 2	57.40	3.65	2.31	13.40	0.050	39.93	13.01	0.33	2.45
Topstuk	59.10	2.31		1.70		1.96	0.33	0.17	3.08
Ondertraverse	34.50	9.95		3.10		15.42	4.52	0.29	2.56
Middentraverse	44.00	13.30		3.20		21.28	6.53	0.31	2.51
Boventraverse	54.00	15.68		5.10		39.97	7.67	0.19	2.97

### Eigenschappen mastsecties dwarsrichting (zijaanzicht, xz-vlak)

Omschrijving	h [m]	b <sub>1</sub> [m]	b <sub>2</sub> [m]	Δh [m]	Δ <sub>x</sub> [m]	A <sub>0</sub> [m <sup>2</sup> ]	A <sub>1</sub> [m <sup>2</sup> ]	χ = A <sub>1</sub> /A <sub>0</sub> [-]	C <sub>t</sub>
Broekstuk	21.40	14.04	5.91	21.40	0.190	213.49	49.54	0.23	2.79
Eerste tussenstuk	28.20	5.91	5.23	6.80	0.050	37.88	13.54	0.36	2.34
Tweede tussenstuk	34.50	5.23	4.60	6.30	0.050	30.96	9.94	0.32	2.46
Bovenstuk 1	44.00	4.60	3.65	9.50	0.050	39.19	12.67	0.32	2.45
Bovenstuk 2	57.40	3.65	2.31	13.40	0.050	39.93	13.01	0.33	2.45
Topstuk	59.10	2.31		1.70		1.96	0.33	0.17	3.08
Ondertraverse	34.50	9.95		3.10		15.42	4.52	0.29	2.56
Middentraverse	44.00	13.30		3.20		21.28	6.53	0.31	2.51
Boventraverse	54.00	15.68		5.10		39.97	7.67	0.19	2.97

NB: oppervlakte traverse dwarsrichting van de tabel wordt in berekening gereduceerd.  
 NB: oppervlakte traverse per zijde, dus helft van totaal van twee traveres.



Project: RLL-TLB380  
 Tower: HB+6\_c - 160gr  
 Number: 1079

#### Windoppervlak feeders telecominstallaties

Onderdeel	A (m <sup>2</sup> /m)	Factor	Δh	A <sub>1</sub>
Broekstuk	0.14	0.71	21.4	2.1
Eerste tussenstuk	0.14	0.71	6.8	0.7
Tweede tussenstuk	0.14	0.71	6.3	0.6
Bovenstuk 1	0.14	0.71	9.5	0.9
Bovenstuk 2				

#### Invoer antennes

Omschrijving	A (m <sup>2</sup> )	h (m)	C <sub>i</sub> (m)
Antenne top			
Antenne o.t.	4.7	40.7	1.5

#### Belastingen mastsectie langsrichting (x-richting) per windrichting

Omschrijving	P <sub>w</sub> [kN/m <sup>2</sup> ]	F <sub>x1</sub> [kN]	F <sub>x2</sub> [kN]	F <sub>x3</sub> [kN]	F <sub>x4</sub> [kN]	h <sub>ef</sub> [m]	M <sub>y1</sub> [kNm]	M <sub>y2</sub> [kNm]	M <sub>y3</sub> [kNm]	M <sub>y4</sub> [kNm]
Broekstuk	0.72	99.4	84.3	0.0	-84.3	10.7	1063.2	902.2	0.0	-902.2
Eerste tussenstuk	0.94	29.7	25.2	0.0	-25.2	24.8	736.1	624.6	0.0	-624.6
Tweede tussenstuk	1.00	24.5	20.8	0.0	-20.8	31.4	767.4	651.2	0.0	-651.2
Bovenstuk 1	1.07	33.2	28.2	0.0	-28.2	39.3	1303.9	1106.4	0.0	-1106.4
Bovenstuk 2	1.14	36.3	30.8	0.0	-30.8	50.7	1837.9	1559.5	0.0	-1559.5
Topstuk	1.18	1.2	1.0	0.0	-1.0	58.3	69.6	59.1	0.0	-59.1
Ondertraverse	1.04	24.0	14.2	0.0	-14.2	35.5	852.1	506.1	0.0	-506.1
Middentraverse	1.10	36.2	21.5	0.0	-21.5	45.1	1632.0	969.4	0.0	-969.4
Boventraverse	1.17	53.1	31.6	0.0	-31.6	55.7	2960.0	1758.2	0.0	-1758.2
<b>Totaal</b>		<b>337.5</b>	<b>257.6</b>	<b>0.0</b>	<b>-257.6</b>		<b>11222.3</b>	<b>8136.6</b>	<b>0.0</b>	<b>-8136.6</b>

#### Belastingen mastsectie dwarsrichting (y-richting) per windrichting

Omschrijving	P <sub>w</sub> [kN/m <sup>2</sup> ]	F <sub>y1</sub> [kN]	F <sub>y2</sub> [kN]	F <sub>y3</sub> [kN]	F <sub>y4</sub> [kN]	h <sub>ef</sub> [m]	M <sub>x1</sub> [kNm]	M <sub>x2</sub> [kNm]	M <sub>x3</sub> [kNm]	M <sub>x4</sub> [kNm]
Broekstuk	0.72	0.0	84.3	99.4	84.3	10.7	0.0	902.2	1063.2	902.2
Eerste tussenstuk	0.94	0.0	25.2	29.7	25.2	24.8	0.0	624.6	736.1	624.6
Tweede tussenstuk	1.00	0.0	20.8	24.5	20.8	31.4	0.0	651.2	767.4	651.2
Bovenstuk 1	1.07	0.0	28.2	33.2	28.2	39.3	0.0	1106.4	1303.9	1106.4
Bovenstuk 2	1.14	0.0	30.8	36.3	30.8	50.7	0.0	1559.5	1837.9	1559.5
Topstuk	1.18	0.0	1.0	1.2	1.0	58.3	0.0	59.1	69.6	59.1
Ondertraverse	1.04	0.0	14.2	9.6	14.2	35.5	0.0	506.1	340.9	506.1
Middentraverse	1.10	0.0	21.5	14.5	21.5	45.1	0.0	969.4	652.8	969.4
Boventraverse	1.17	0.0	31.6	21.3	31.6	55.7	0.0	1758.2	1184.0	1758.2
<b>Totaal</b>		<b>0.0</b>	<b>257.6</b>	<b>269.5</b>	<b>257.6</b>		<b>0.0</b>	<b>8136.6</b>	<b>7955.8</b>	<b>8136.6</b>

#### Resulterende belastingen vanuit mastconstructie incl. antenne zonder geleiders niveau fundatie (kar. waarde)

Belasting / windrichting	F <sub>x</sub> [kN]	F <sub>y</sub> [kN]	F <sub>z</sub> [kN]	M <sub>x</sub> [kNm]	M <sub>y</sub> [kNm]	M <sub>z</sub> [kNm]
Permanente belasting	0	0	1140	0	0	0
Windrichting 0°	345	0	0	0	11531	0
Windrichting 45°	263	263	0	8355	8355	0
Windrichting 90°	0	277	0	8264	0	0
Windrichting 135°	-263	263	0	8355	-8355	0

Project: RLL-TLB380  
 Tower: HB+6\_c - 160gr  
 Number: 1079

### Tussenresultaten geleiderbelastingen

#### Geleiders back

Circuit	Geleider	Diameter [mm]	A [mm <sup>2</sup> ]	G [N/m]	E [N/mm <sup>2</sup> ]	$\alpha T$ [-]
Circuit 1	AAAC-AL7 620	32.4	621.0	17.71	56000	2.30E-05
Circuit 2	AAAC-AL7 620	32.4	621.0	17.71	56000	2.30E-05
Circuit 3	AAAC-AL7 620	32.4	621.0	17.71	56000	2.30E-05
Circuit 4	AAAC-AL7 620	32.4	621.0	17.71	56000	2.30E-05
Bliksemdraad 1	AACSR 241-AL3-39-A20SA	21.8	281.0	9.38	70165	1.97E-05
Bliksemdraad 2	OPGW AFL-226/38	21.7	264.0	9.13	72000	1.98E-05

#### Geleiders ahead

Circuit	Geleider	Diameter [mm]	A [mm <sup>2</sup> ]	G [N/m]	E [N/mm <sup>2</sup> ]	$\alpha T$ [-]
Circuit 1	AAAC-AL7 620	32.4	621.0	17.71	56000	2.30E-05
Circuit 2	AAAC-AL7 620	32.4	621.0	17.71	56000	2.30E-05
Circuit 3	AAAC-AL7 620	32.4	621.0	17.71	56000	2.30E-05
Circuit 4	AAAC-AL7 620	32.4	621.0	17.71	56000	2.30E-05
Bliksemdraad 1	AACSR 241-AL3-39-A20SA	21.8	281.0	9.38	70165	1.97E-05
Bliksemdraad 2	OPGW AFL-226/38	21.7	264.0	9.13	72000	1.98E-05

#### Verticale belasting back

Circuit	Bundel [-]	Toeslag [%]	$W_{z,G}$ [N/m]	IJsgebied	Formule	$W_{z,ijs}$ [N/m]	$W_{z,ijs,bundel}$ [N/m]
Circuit 1	4	3	73.0	B	4+0,2d	10.5	41.9
Circuit 2	4	3	73.0	B	4+0,2d	10.5	41.9
Circuit 3	2	3	36.5	B	4+0,2d	10.5	21.0
Circuit 4	2	3	36.5	B	4+0,2d	10.5	21.0
Bliksemdraad 1	1	2	9.6	A	15+0,4d	23.7	23.7
Bliksemdraad 2	1	2	9.3	A	15+0,4d	23.7	23.7

#### Verticale belasting ahead

Circuit	Bundel [-]	Toeslag [%]	$W_{z,G}$ [N/m]	IJsgebied	Formule	$W_{z,ijs}$ [N/m]	$W_{z,ijs,bundel}$ [N/m]
Circuit 1	4	3	73.0	B	4+0,2d	10.5	41.9
Circuit 2	4	3	73.0	B	4+0,2d	10.5	41.9
Circuit 3	2	3	36.5	B	4+0,2d	10.5	21.0
Circuit 4	2	3	36.5	B	4+0,2d	10.5	21.0
Bliksemdraad 1	1	2	9.6	A	15+0,4d	23.7	23.7
Bliksemdraad 2	1	2	9.3	A	15+0,4d	23.7	23.7

#### Isolatoren

Geleider	$G_{isolator}$ [kN]	Aantal	$F_{v,iso}$ [kN]	Lengte [m]	Windopp. [m <sup>2</sup> ]	Windhoogte [m]	Stuwdruk [kN/m <sup>2</sup> ]	Vormfactor [-]	$F_{h,iso}$ [kN]
380ct1f1	3.00	1	3	6.5	1.1	54.50	1.16	1.2	1.53
380ct1f2	3.00	1	3	6.5	1.1	44.50	1.10	1.2	1.45
380ct1f3	3.00	1	3	6.5	1.1	35.00	1.03	1.2	1.36
380ct2f1	3.00	1	3	6.5	1.1	54.50	1.16	1.2	1.53
380ct2f2	3.00	1	3	6.5	1.1	44.50	1.10	1.2	1.45
380ct2f3	3.00	1	3	6.5	1.1	35.00	1.03	1.2	1.36
150ct3f1	2.00	1	2	4.5	0.8	54.50	1.16	1.2	1.11
150ct3f2	2.00	1	2	4.5	0.8	44.50	1.10	1.2	1.06
150ct3f3	2.00	1	2	4.5	0.8	35.00	1.03	1.2	0.99
150ct4f1	2.00	1	2	4.5	0.8	54.50	1.16	1.2	1.11
150ct4f2	2.00	1	2	4.5	0.8	44.50	1.10	1.2	1.06
150ct4f3	2.00	1	2	4.5	0.8	35.00	1.03	1.2	0.99
bl1	0.10	1	0.1	0.2	0.1	59.60	1.19	1.2	0.14
bl2	0.10	1	0.1	0.2	0.1	59.60	1.19	1.2	0.14

Project: RLL-TLB380  
 Tower: HB+6\_c - 160gr  
 Number: 1079

#### Windbelasting back

Geleider	hoogte		$G_{c\_dwars}$	$G_{c\_trek}$	$C_c$	$d_{toeslag}$	$w_y$	$w_{y,vak}$	$D_{ijs,toeslag}$	$w_{y,ijs}$	$w_{y,ijs,vak}$
	wind [m]	Stuwdruk [kN/m <sup>2</sup> ]									
380ct1f1	53.1	1.15	0.62	0.68	0.95	33.37	91.4	100.4	51.8	178.5	196.2
380ct1f2	43.1	1.09	0.61	0.67	0.97	33.37	85.9	94.5	51.8	164.5	181.0
380ct1f3	33.6	1.02	0.59	0.65	1.00	33.37	79.5	87.5	51.8	148.8	163.8
380ct2f1	53.1	1.15	0.62	0.68	0.95	33.37	91.4	100.4	51.8	178.5	196.2
380ct2f2	43.1	1.09	0.61	0.67	0.97	33.37	85.9	94.5	51.8	164.5	181.0
380ct2f3	33.6	1.02	0.59	0.65	1.00	33.37	79.5	87.5	51.8	148.8	163.8
150ct3f1	53.1	1.15	0.62	0.68	0.95	33.37	45.7	50.2	51.8	89.2	98.1
150ct3f2	43.1	1.09	0.61	0.67	0.97	33.37	42.9	47.2	51.8	82.3	90.5
150ct3f3	33.6	1.02	0.59	0.65	1.00	33.37	39.7	43.7	51.8	74.4	81.9
150ct4f1	53.1	1.15	0.62	0.68	0.95	33.37	45.7	50.2	51.8	89.2	98.1
150ct4f2	43.1	1.09	0.61	0.67	0.97	33.37	42.9	47.2	51.8	82.3	90.5
150ct4f3	33.6	1.02	0.59	0.65	1.00	33.37	39.7	43.7	51.8	74.4	81.9
bl1	58.2	1.18	0.63	0.69	1.18	22.24	19.4	21.3	63.1	56.3	61.8
bl2	58.2	1.18	0.63	0.69	1.18	22.13	19.4	21.3	63.0	56.2	61.8

#### Windbelasting ahead

Geleider	hoogte		$G_{c\_dwars}$	$G_{c\_trek}$	$C_c$	$d_{toeslag}$	$w_y$	$w_{y,vak}$	$D_{ijs,toeslag}$	$w_{y,ijs}$	$w_{y,ijs,vak}$
	wind [m]	Stuwdruk [kN/m <sup>2</sup> ]									
380ct1f1	50.1	1.14	0.62	0.68	0.96	33.37	89.8	98.8	51.8	174.5	191.9
380ct1f2	40.1	1.07	0.60	0.66	0.98	33.37	84.0	92.4	51.8	159.9	175.9
380ct1f3	30.6	0.99	0.58	0.64	1.00	33.37	77.1	84.9	51.8	143.2	157.6
380ct2f1	50.1	1.14	0.62	0.68	0.96	33.37	89.8	98.8	51.8	174.5	191.9
380ct2f2	40.1	1.07	0.60	0.66	0.98	33.37	84.0	92.4	51.8	159.9	175.9
380ct2f3	30.6	0.99	0.58	0.64	1.00	33.37	77.1	84.9	51.8	143.2	157.6
150ct3f1	50.1	1.14	0.62	0.68	0.96	33.37	44.9	49.4	51.8	87.3	95.9
150ct3f2	40.1	1.07	0.60	0.66	0.98	33.37	42.0	46.2	51.8	79.9	88.0
150ct3f3	30.6	0.99	0.58	0.64	1.00	33.37	38.6	42.4	51.8	71.6	78.8
150ct4f1	50.1	1.14	0.62	0.68	0.96	33.37	44.9	49.4	51.8	87.3	95.9
150ct4f2	40.1	1.07	0.60	0.66	0.98	33.37	42.0	46.2	51.8	79.9	88.0
150ct4f3	30.6	0.99	0.58	0.64	1.00	33.37	38.6	42.4	51.8	71.6	78.8
bl1	55.2	1.17	0.62	0.69	1.18	22.24	19.1	21.0	63.1	55.2	60.6
bl2	55.2	1.17	0.62	0.69	1.18	22.13	19.0	20.9	63.0	55.1	60.5

NB: belastingen  $w_v$  gelden voor bundel

Project: RLL-TLB380  
 Masttype: HB+6\_c - 160gr  
 Mast: 1079

Auteur: TBR  
 Versie: v12.0

### Geleiderbelastingen

#### Uitgangspunten

Betrouwbaarheidsniveau Nieuwbouw CC2  
 Referentieperiode 50 jaar

ULS (bezwijksterkte)		NEN-EN50341-2-15:2019							
Belastingsgeval	omschrijving	Temp °C	$\gamma_G$		$\gamma_Q$			$\gamma_a$ $A_k$	
			$G_{k,mast}$	$G_{k,geleider}$	$Q_{pk}$	$Q_{wk}$	$Q_{ik}$		
ULS 1a	Wind	10°	1.20	1.20	0.00	1.50	0.00	0.0	
ULS 1a_0,9	Wind 0,9Gk alleen mast	10°	0.90	1.20	0.00	1.50	0.00	0.0	
ULS 1a_0,9_0,9	Wind 0,9Gk ook geleider	10°	0.90	0.90	0.00	1.50	0.00	0.0	
ULS 3	Wind+ijs	-5°	1.20	1.20	0.00	0.45	1.50	0.0	
ULS 3_0,9	Wind+ijs 0,9	-5°	0.90	1.20	0.00	0.45	1.50	0.0	
ULS 4	Koude+wind	-20°	1.20	1.20	0.00	0.30	0.00	0.0	
ULS 4_0,9	Koude+wind 0,9	-20°	0.90	1.20	0.00	0.30	0.00	0.0	
ULS 5a	Torsiebelastingen	10°	1.00	1.00	1.00	0.00	0.00	1.0	
ULS 5b	Longitudinale belastingen	10°	1.00	1.00	0.00	0.00	0.00	1.0	
ULS 6	Bouw en onderhoud	5°	1.20	1.20	1.50	0.30	0.00	0.0	
ULS 6_0,9	Bouw en onderhoud	5°	1.20	1.20	0.00	0.30	0.00	0.0	
ULS 7	Permanent	10°	1.35	1.35	0.00	0.00	0.00	0.0	
ULS 8	Special	10°	1.00	1.00	0.00	0.00	0.00	1.0	
<b>SPLS</b> (Bezwijksterkte, enkel voor hoekmasten: afwezigheid geleiders)				$\gamma_G$ $G_k$	$\gamma_Q$ $Q_{pk}$ $Q_{wk}$ $Q_{ik}$			$A_k$	
SPLS 1a	Wind	10°	1.20	1.20	0.0	0.78	0.00	0.0	
SPLS 1a_0,9	Wind 0,9	10°	0.90	1.20	0.0	0.78	0.00	0.0	
SPLS 1a_0,9_0,9	Wind 0,9	10°	0.90	0.90	0.0	0.78	0.00	0.0	
SPLS 3	Wind+ijs	-5°	1.20	1.20	0.0	0.36	0.34	0.0	
SPLS 3_0,9	Wind+ijs 0,9	-5°	0.90	1.20	0.0	0.36	0.34	0.0	
SPLS 4	Koude+wind	-20°	1.20	1.20	0.0	0.24	0.00	0.0	
SPLS 4_0,9	Koude+wind 0,9	-20°	0.90	1.20	0.0	0.24	0.00	0.0	
SPLS 6	Bouw en onderhoud	5°	1.20	1.20	1.2	0.24	0.0	0.0	
SPLS 6_0,9	Bouw en onderhoud	5°	1.20	1.20	0.0	0.24	0.0	0.0	
<b>SLS</b> (controle van de vervormingen, vermoeiing, EDS)				$G_k$	$Q_{pk}$	$Q_{wk}$	$Q_{ik}$	$A_k$	
SLS 1a	Wind	10°	1.00	1.00	0.0	1.00	0.0	0.0	
SLS 3	Wind+ijs	-5°	1.00	1.00	0.0	0.30	1.00	0.0	
SLS 4	Wind	-20°	1.00	1.00	0.0	0.20	0.0	0.0	
SLS 6	Bouw en onderhoud	5°	1.00	1.00	0.0	0.20	0.0	0.0	
SLS 7	PB (EDS, geen wind)	10°	1.00	1.00	0.0	0.00	0.0	0.0	

Aantal windrichtingen 6  
 Aantal belastingcombinaties ULS 100  
 Aantal belastingcombinaties SPLS 246  
 Aantal belastingcombinaties SLS 15  
 Aantal knooplasten 12274

Project: RLL-TLB380  
 Masttype: HB+6\_c - 160gr  
 Mast: 1079

### Samenvattingstabellen geleiderbelastingen

In de onderstaande vier tabellen is weergegeven:

- De maximale geleiderbelasting in het globale assenstelsel, gesplitst in aandeel van back en ahead span
- De gecombineerde geleiderbelasting (Ba+Ah) in het globale assenstelsel met in het lokale assenstelsel de maximaal optredende trekkracht. Componenten Fx en Fy als absolute waarde
- De alledaagse (EDS) waarden van de gecombineerde geleiderbelastingen (Ba+Ah) met bijbehorende trekkrachten
- Controle op uplift, waar een negatieve waarde duidt op uplift

#### Maximale waarden voor back en ahead span

Geleider	Fx_ba [kN]	Fx_ah [kN]	Fy_ba [kN]	Fy_ah [kN]	Fz_ba [kN]	Fz_ah [kN]
bl1	-65.9	65.7	16.8	16.7	11.1	11.1
380ct1f1	-265.6	264.6	74.5	73.6	39.8	39.8
380ct1f2	-262.0	260.8	71.3	70.3	39.7	39.7
380ct1f3	-258.2	256.9	67.7	66.3	39.6	39.6
Post-isolato	0.0	0.0	0.0	0.0	0.0	
Post-isolato	0.0	0.0	0.0	0.0	0.0	
Post-isolato	0.0	0.0	0.0	0.0	0.0	
380ct2f1	-265.6	264.6	74.5	73.6	39.8	39.8
380ct2f2	-262.0	260.8	71.3	70.3	39.7	39.7
380ct2f3	-258.2	256.9	67.7	66.3	39.6	39.6
150ct3f1	-132.8	132.3	37.7	37.3	21.3	21.3
150ct3f2	-131.0	130.4	36.2	35.6	21.3	21.3
150ct3f3	-129.1	128.4	34.3	33.7	21.3	21.3
150ct4f1	-132.8	132.3	37.7	37.3	21.3	21.3
150ct4f2	-131.0	130.4	36.2	35.6	21.3	21.3
150ct4f3	-129.1	128.4	34.3	33.7	21.3	21.3
bl2	-65.0	64.8	16.7	16.5	11.0	11.0
Post-isolato	0.0	0.0	0.0	0.0	0.0	
Post-isolato	0.0	0.0	0.0	0.0	0.0	
Post-isolato	0.0	0.0	0.0	0.0	0.0	

#### Min. Weight span (m)

Weight spar Combinatie1

Geleider	SLS 1a	SLS 4	SLS 7
bl1	481.1	498.3	481.0
380ct1f1	481.1	496.6	481.0
380ct1f2	481.0	496.3	481.0
380ct1f3	481.0	496.0	481.0
Post-isolator 1			
Post-isolator 2			
Post-isolator 3			
380ct2f1	481.1	496.6	481.0
380ct2f2	481.0	496.3	481.0
380ct2f3	481.0	496.0	481.0
150ct3f1	481.1	496.6	481.0
150ct3f2	481.0	496.3	481.0
150ct3f3	481.0	496.0	481.0
150ct4f1	481.1	496.6	481.0
150ct4f2	481.0	496.3	481.0
150ct4f3	481.0	496.0	481.0
bl2	481.2	498.6	481.0
Post-isolator 4			
Post-isolator 5			
Post-isolator 6			

#### Max. Weight span (m)

Weight spar Combinatie1

Geleider	ULS 1a	ULS 3
bl1	578.2	464.4
380ct1f1	530.9	480.9
380ct1f2	526.4	479.8
380ct1f3	521.1	478.6
Post-isolator 1		
Post-isolator 2		
Post-isolator 3		
380ct2f1	530.9	480.9
380ct2f2	526.4	479.8
380ct2f3	521.1	478.6
150ct3f1	530.9	480.9
150ct3f2	526.4	479.8
150ct3f3	521.1	478.6
150ct4f1	530.9	480.9
150ct4f2	526.4	479.8
150ct4f3	521.1	478.6
bl2	580.7	464.0
Post-isolator 4		
Post-isolator 5		
Post-isolator 6		

Omhullende weight span over alle combinaties (incl. 0,9 combinaties)

Over alle geleiders	Wind / Weight span verhouding
Max. weight span	578.2 m / 1.445 -
Min. weight span	166.8 m / 0.417 -

Project: RLL-TLB380  
 Masttype: HB+6\_c - 160gr  
 Mast: 1079

**Maximale waarden back+ahead span      Maximale waarden trekkracht geleider**

Geleider	Maximale waarden back+ahead span		Maximale waarden trekkracht geleider		
	Fx [kN]	Fy [kN]	Fz [kN]	Ft_ba [kN]	Ft_ah [kN]
bl1	39.2	33.1	11.1	-67.8	67.6
380ct1f1	206.9	144.8	39.8	-272.7	271.5
380ct1f2	203.1	138.5	39.7	-268.8	267.5
380ct1f3	199.0	131.1	39.6	-264.7	263.3
Post-isolato	4.4	4.4	6.8	0.0	
Post-isolato	3.4	3.4	4.7	0.0	
Post-isolato	5.0	5.0	6.8	0.0	
380ct2f1	206.9	144.8	39.8	-272.7	271.5
380ct2f2	203.1	138.5	39.7	-268.8	267.5
380ct2f3	199.0	131.1	39.6	-264.7	263.3
150ct3f1	108.3	73.4	21.3	-136.3	135.8
150ct3f2	108.2	70.2	21.3	-134.4	133.8
150ct3f3	108.1	66.5	21.3	-132.3	131.6
150ct4f1	108.3	73.4	21.3	-136.3	135.8
150ct4f2	108.2	70.2	21.3	-134.4	133.8
150ct4f3	108.1	66.5	21.3	-132.3	131.6
bl2	38.6	32.8	11.0	-66.9	66.7
Post-isolato	4.4	4.4	6.8	0.0	
Post-isolato	3.4	3.4	4.7	0.0	
Post-isolato	5.0	5.0	6.8	0.0	

**EDS-belastingen geleiders**

Geleider	EDS-belastingen geleiders		EDS-belastingen geleiders		
	Fx [kN]	Fy [kN]	Fz [kN]	Ft_ba [kN]	Ft_ah [kN]
bl1	17.0	3.0	2.4	-17.2	17.2
380ct1f1	129.3	22.8	20.5	-131.3	131.3
380ct1f2	129.3	22.8	20.5	-131.3	131.3
380ct1f3	129.3	22.8	20.5	-131.3	131.3
Post-isolato	0.0	0.0	5.0	0.0	
Post-isolato	0.0	0.0	3.5	0.0	
Post-isolato	0.0	0.0	5.0	0.0	
380ct2f1	129.3	22.8	20.5	-131.3	131.3
380ct2f2	129.3	22.8	20.5	-131.3	131.3
380ct2f3	129.3	22.8	20.5	-131.3	131.3
150ct3f1	64.7	11.4	10.8	-65.7	65.7
150ct3f2	64.7	11.4	10.8	-65.7	65.7
150ct3f3	64.7	11.4	10.8	-65.7	65.7
150ct4f1	64.7	11.4	10.8	-65.7	65.7
150ct4f2	64.7	11.4	10.8	-65.7	65.7
150ct4f3	64.7	11.4	10.8	-65.7	65.7
bl2	16.5	2.9	2.3	-16.8	16.8
Post-isolato	0.0	0.0	5.0	0.0	
Post-isolato	0.0	0.0	3.5	0.0	
Post-isolato	0.0	0.0	5.0	0.0	

**Controle uplift SLS-wind**

Combinatie: Geleider	Controle uplift SLS-wind	
	Fz_ba [kN]	Fz_ah [kN]
SLS 4		
bl1	0.0	0.0
380ct1f1	0.0	0.0
380ct1f2	0.0	0.0
380ct1f3	0.0	0.0
Post-isolato	0.0	
Post-isolato	0.0	
Post-isolato	0.0	
380ct2f1	0.0	0.0
380ct2f2	0.0	0.0
380ct2f3	0.0	0.0
150ct3f1	0.0	0.0
150ct3f2	0.0	0.0
150ct3f3	0.0	0.0
150ct4f1	0.0	0.0
150ct4f2	0.0	0.0
150ct4f3	0.0	0.0
bl2	0.0	0.0
Post-isolato	0.0	
Post-isolato	0.0	
Post-isolato	0.0	

Project: RLL-TLB380  
 Masttype: HB+6\_c - 160gr  
 Mast: 1079

**ULS-fundatiebelasting combinatie 1 en 3 wind haaks op de lijn of bissectrice en EDS, vanuit geleiders**

Combinatie	Combination	$F_x$ [kN]	$F_y$ [kN]	$F_z$ [kN]	$M_x$ [kNm]	$M_y$ [kNm]	$M_z$ [kNm]
ULS 1a_90		-27	1329	533	59913	-1151	0
ULS 1a_0.9_0		28	490	358	21843	1265	0
ULS 1a_0.9_0.9_90		-29	1289	223	58143	-1260	0
ULS 3_0		9	806	788	36230	413	0
SLS 7		0	422	412	18826	0	0

**ULS-fundatiebelasting combinatie 1 en 3 wind haaks op de lijn of bissectrice en EDS, totaal geleiders en mast**

Combinatie	$F_x$ [kN]	$F_y$ [kN]	$F_z$ [kN]	$M_x$ [kNm]	$M_y$ [kNm]	$M_z$ [kNm]
ULS 1a_90	-27	1745	1900	72310	-1151	0
ULS 1a_0.9_0.9_90	-29	1704	1249	70539	-1260	0
SLS 7	0	422	1552	18826	0	0

**Fundatiebelastingen, selectie belastingcombinaties op basis grootste waarde**

Combinatie	$F_x$ [kN]	$F_y$ [kN]	$F_z$ [kN]	$M_x$ [kNm]	$M_y$ [kNm]	$M_z$ [kNm]
ULS 1a_0.9_90	-27	1745	1343	<b>72310</b>	-1151	0
SPLS 3_80 Ah All Cts	-1886	513	1705	21545	<b>-84924</b>	9
SPLS 3_80 Ba Ct1	913	692	1820	30817	40658	<b>-10162</b>
SPLS 3_0.9_80 Ah All Cts	-1886	513	1253	<b>21545</b>	<b>-84924</b>	9

*Noot: grootste waarden kunnen in meerdere combinaties voorkomen, een combinatie is weergegeven.*

**Oplegreacties op fundering per randstijl**

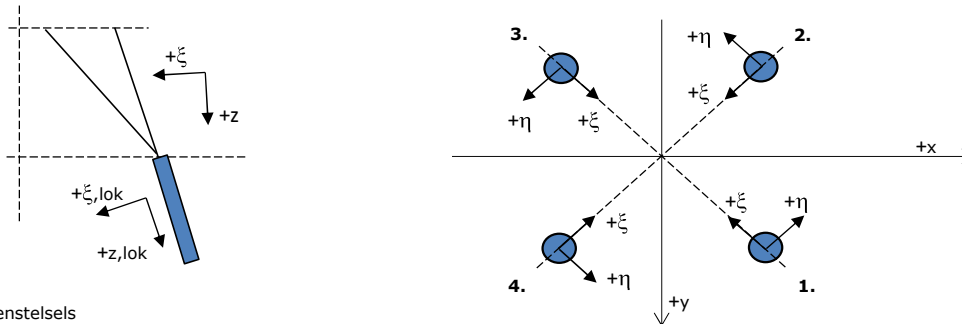

Assenstelsels

**Maximale drukbelasting**

Stijl	Combinatie	$R_x$ [kN]	$R_y$ [kN]	$R_z$ [kN]	$R_\eta$ [kN]	$R_\xi$ [kN]	$R_{\xi,lok}$ [kN]	$R_{z,lok}$ [kN]
1	SPLS 3_100 Ba All Cts	717	845	<b>4193</b>	-91	-1104	23	4342
2	SPLS 3_0 Ba All Cts	441	-601	<b>2761</b>	113	-736	6	2859
3	ULS 8 Ba	-429	-602	<b>2756</b>	-122	-729	12	2854
4	SPLS 3_80 Ah All Cts	-721	850	<b>4217</b>	91	-1110	23	4367

**Maximale trekbelasting**

Stijl	Combinatie	$R_x$ [kN]	$R_y$ [kN]	$R_z$ [kN]	$R_\eta$ [kN]	$R_\xi$ [kN]	$R_{\xi,lok}$ [kN]	$R_{z,lok}$ [kN]
1	SPLS 3_0.9_90 Ah All Cts	-249	-440	<b>-1951</b>	135	487	-38	-2020
2	SPLS 3_0.9_80 Ah All Cts	-566	695	<b>-3478</b>	-91	892	-43	-3601
3	SPLS 3_0.9_100 Ba All Cts	561	688	<b>-3446</b>	90	883	-43	-3569
4	SPLS 3_0.9_0 Ba All Cts	284	-445	<b>-2015</b>	-114	516	-26	-2087

**Maximale torsiebelasting (positief)**

Stijl	Combinatie	$R_x$ [kN]	$R_y$ [kN]	$R_z$ [kN]	$R_\eta$ [kN]	$R_\xi$ [kN]	$R_{\xi,lok}$ [kN]	$R_{z,lok}$ [kN]
1	SPLS 3_90 Ah Ct1	268	-226	47	<b>350</b>	-30	-17	49
2	SPLS 3_0.9_90 Ba Ct2	-93	-387	788	<b>340</b>	-208	4	816
3	SPLS 3_90 Ba Ct2	173	572	-2061	<b>282</b>	526	-28	-2134
4	SPLS 3_0.9_90 Ah Ct1	-359	742	2954	<b>271</b>	-778	16	3059

**Maximale torsiebelasting (negatief)**

Index	Combinatie	$R_x$ [kN]	$R_y$ [kN]	$R_z$ [kN]	$R_\eta$ [kN]	$R_\xi$ [kN]	$R_{\xi,lok}$ [kN]	$R_{z,lok}$ [kN]
1	SPLS 3_0.9_90 Ba Ct1	353	737	2923	<b>-272</b>	-771	15	3026
2	SPLS 3_90 Ah Ct2	-179	576	-2091	<b>-281</b>	534	-28	-2165
3	SPLS 3_0.9_90 Ah Ct2	88	-390	814	<b>-338</b>	-214	5	843
4	SPLS 3_90 Ba Ct1	-273	-222	72	<b>-350</b>	-36	-17	74

Project: RLL-TLB380  
 Masttype: HB+6\_c - 160gr  
 Mast: 1079

#### Combinatie Ftrek+Fhor

Stijl	Combinatie	R <sub>x</sub> [kN]	R <sub>y</sub> [kN]	R <sub>z</sub> [kN]	R <sub>η</sub> [kN]	R <sub>ξ</sub> [kN]	R <sub>ξ,lok</sub> [kN]	R <sub>z,lok</sub> [kN]
1	SPLS 3_0.9_90 Ah All Cts	-249	-440	<b>-1951</b>	<b>135</b>	487	-38	-2020
2	SPLS 3_0.9_80 Ah All Cts	-566	695	<b>-3478</b>	<b>-91</b>	892	-43	-3601
3	SPLS 3_0.9_100 Ba All Cts	561	688	<b>-3446</b>	<b>90</b>	883	-43	-3569
4	SPLS 3_0.9_0 Ba All Cts	284	-445	<b>-2015</b>	<b>-114</b>	516	-26	-2087

#### Permanente belasting

Stijl	Combinatie	R <sub>x</sub> [kN]	R <sub>y</sub> [kN]	R <sub>z</sub> [kN]	R <sub>η</sub> [kN]	R <sub>ξ</sub> [kN]	R <sub>ξ,lok</sub> [kN]	R <sub>z,lok</sub> [kN]
1	SLS 7	221	187	1058	24	-288	-4	1096
2	SLS 7	-59	24	-282	24	59	-17	-292
3	SLS 7	59	24	-282	-24	59	-17	-292
4	SLS 7	-221	187	1058	-24	-288	-4	1096

#### Omhullenden ongeacht stijl

Belasting	Combinatie	R <sub>x</sub> [kN]	R <sub>y</sub> [kN]	R <sub>z</sub> [kN]	R <sub>η</sub> [kN]	R <sub>ξ</sub> [kN]	R <sub>ξ,lok</sub> [kN]	R <sub>z,lok</sub> [kN]
Max. druk	SPLS 3_80 Ah All Cts	-721	850	<b>4217</b>	91	-1110	23	4367
Max. trek	SPLS 3_0.9_80 Ah All Cts	-566	695	<b>-3478</b>	-91	892	-43	-3601
Max. pos. torsie	SPLS 3_90 Ah Ct1	268	-226	47	<b>350</b>	-30	-17	49
Max. neg. torsie	SPLS 3_90 Ba Ct1	-273	-222	72	<b>-350</b>	-36	-17	74
Comb. trek+torsie	SPLS 3_0.9_80 Ah All Cts	-566	695	<b>-3478</b>	<b>-91</b>	892	-43	-3601

#### Maximale trekbelasting SLS

Stijl	Combinatie	R <sub>x</sub> [kN]	R <sub>y</sub> [kN]	R <sub>z</sub> [kN]	R <sub>η</sub> [kN]	R <sub>ξ</sub> [kN]	R <sub>ξ,lok</sub> [kN]	R <sub>z,lok</sub> [kN]
1	SPLS 3_0.9_90 Ah All Cts	-249	-440	<b>-1951</b>	135	487	-38	-2020
2	SPLS 3_0.9_80 Ah All Cts	-566	695	<b>-3478</b>	-91	892	-43	-3601
3	SPLS 3_0.9_100 Ba All Cts	561	688	<b>-3446</b>	90	883	-43	-3569
4	SPLS 3_0.9_0 Ba All Cts	284	-445	<b>-2015</b>	-114	516	-26	-2087

#### Maximale drukbelasting SLS

Stijl	Combinatie	R <sub>x</sub> [kN]	R <sub>y</sub> [kN]	R <sub>z</sub> [kN]	R <sub>η</sub> [kN]	R <sub>ξ</sub> [kN]	R <sub>ξ,lok</sub> [kN]	R <sub>z,lok</sub> [kN]
1	SPLS 3_0.9_100 Ba All Cts	694	823	<b>4087</b>	-91	-1073	26	4232
2	SPLS 3_0.9_0 Ba All Cts	419	-579	<b>2658</b>	113	-706	8	2752
3	SPLS 3_80 Ah All Cts	-400	-593	<b>2683</b>	-136	-702	19	2778
4	SPLS 3_80 Ah All Cts	-721	850	<b>4217</b>	91	-1110	23	4367



Project: RLL-TLB380  
Masttype: HB+6\_c - 160gr  
Mast: 1079

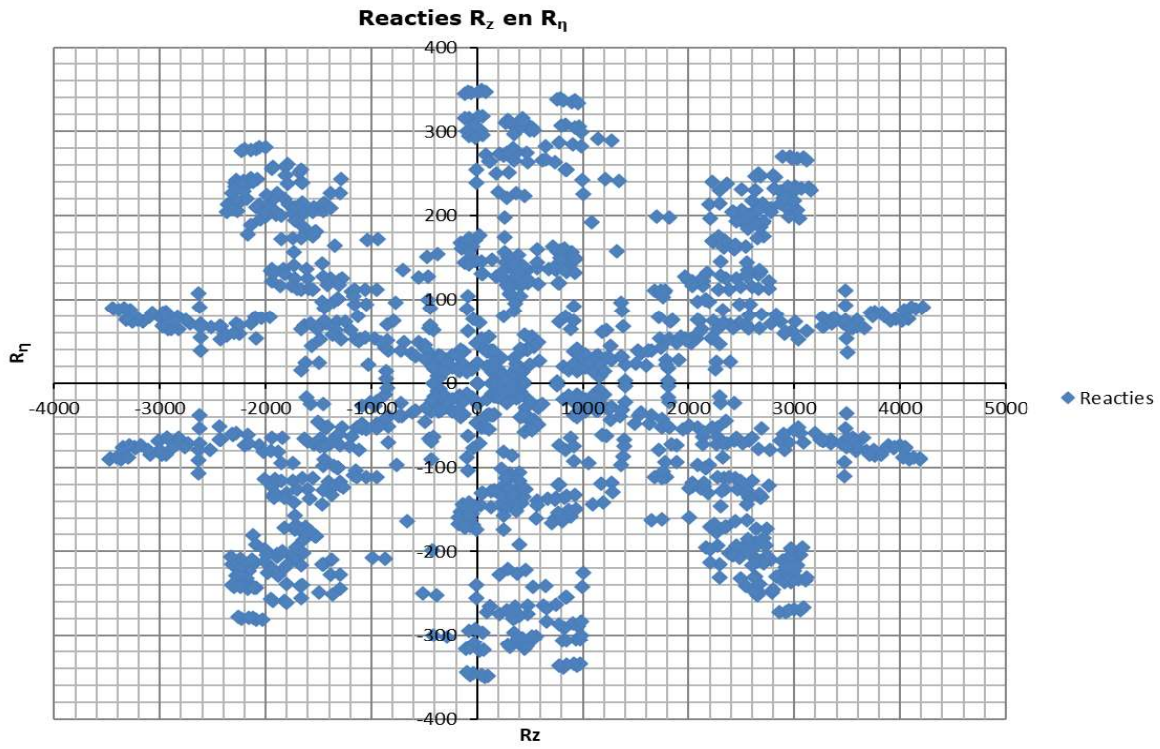



Project: RLL-TLB380  
 Tower: HB+6\_c - bouwfase  
 Number: 1079

Auteur: TBR  
 Versie: v12.0

### Geleiderbelastingen

#### Algemeen

Benaming HB+6\_c - bouwfase  
 Masttype Hoekmast  
 Aantal circuits 2  
 Configuratie 2-circuit-verticaal  
 Aantal bliksemgeleiders 1

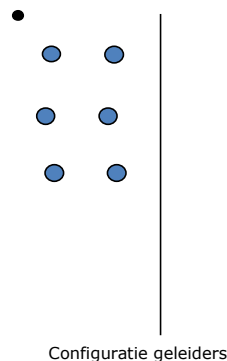

#### Uitgangspunten

Norm NEN-EN50341-2-15:2019  
 Gevolgklasse initieel CC2  
 Betrouwbaarheidsniveau initieel Nieuwbouw  
 Referentieperiode initieel 15 jaar  
 CC2  
 Betrouwbaarheidsniveau na aanpassing n.v.t.  
 15 jaar  
 Windgebied III  
 Windsnelheid (m/s) 24.5 m/s  
 Terreincategorie II  
 Reductiefactor  $C_{dir}$  1.00  
 IJsg gebied fasegeleider B  
 IJsg gebied bliksemgeleider A

#### Geleiders Back

Omschrijving	Spanning	Geleider Back	Bundel Ba	IJsg gebied	Toeslag gewicht	Toeslag diameter	Intrekwaarden $P_{back}$
Circuit 1	380 kV	AAAC-AL7 620	4	B	3 %	3 %	1800
Circuit 2	150 kV	AAAC-AL7 620	2	B	3 %	3 %	1800
Bliksemdraad 1		AACSR 241-AL3-39-A20SA	1	A	2 %	2 %	1800

#### Geleiders Ahead

Omschrijving	Spanning	Geleider Ahead	Bundel Ah	IJsg gebied	Toeslag gewicht	Toeslag diameter	Intrekwaarden $P_{ahead}$
Circuit 1	380 kV	AAAC-AL7 620	4	B	3 %	3 %	1800
Circuit 2	150 kV	AAAC-AL7 620	2	B	3 %	3 %	1800
Bliksemdraad 1		AACSR 241-AL3-39-A20SA	1	A	2 %	2 %	1800

#### Isolatoren (1)

Omschrijving	Ophanging	Gewicht [kN]	Lengte [m]	Windopp. [m <sup>2</sup> ]
Circuit 1	Afspanketting	3.00	6.50	1.10
Circuit 2	Afspanketting	3.00	6.50	1.10
Bliksemdraad 1	Afspanketting	0.10	0.20	0.10

1. Eigenschappen gelden voor geheel van de isolatorset

#### Ophanghoogte en positie in mast

Circuits	Aanduiding	Nummer	Ophanghoogte	Aangrijppunt	Positie in mast Horizontale afstand
Circuit 1	10	380ct1f1	54.0 m	54.0 m	-11.3 m
Circuit 1	11	380ct1f2	44.0 m	44.0 m	-14.8 m
Circuit 1	12	380ct1f3	34.5 m	34.5 m	-11.9 m
Circuit 2	40	150ct2f1	54.0 m	54.0 m	-4.5 m
Circuit 2	41	150ct2f2	44.0 m	44.0 m	-8.0 m
Circuit 2	42	150ct2f3	34.5 m	34.5 m	-5.1 m
Bliksemdraad 1	1	bl1	59.1 m	59.1 m	-17.0 m

Project: RLL-TLB380  
 Tower: HB+6\_c - bouwfase  
 Number: 1079

**Hoogteaanpassing naastgelegen masten** (aanpassing wind- en weight span)

	Back	Ahead	
Verhoging voor windbelasting	12.0 m	6.0 m	(positief: omhoog)
Verlaging voor verticale belasting	-9.0 m	-9.0 m	(negatief: omlaag, grotere weight span)
Verlaging:	Niet in 0,9EG-combinaties		

**Hoogteafwijking mastbeeld naastgelegen masten en richtingsverandering t.o.v. Lijnrichting**

Circuits	Aanduiding	Nummer	Hoogteverschil		Richtingsverandering	
			$\Delta h$ back	$\Delta h$ ahead	$\Delta y$ back	$\Delta y$ ahead
Circuit 1	10	380ct1f1	0.0	0.0 m	0.0	0.0 m
Circuit 1	11	380ct1f2	0.0	0.0 m	0.0	0.0 m
Circuit 1	12	380ct1f3	0.0	0.0 m	0.0	0.0 m
Circuit 2	40	150ct2f1	0.0	0.0 m	0.0	0.0 m
Circuit 2	41	150ct2f2	0.0	0.0 m	0.0	0.0 m
Circuit 2	42	150ct2f3	0.0	0.0 m	0.0	0.0 m
Bliksemdraad 1	1	bl1	0.0	0.0 m	0.0	0.0 m

**Lijn- en mastgegevens**

	Back	Ahead
Ruling span $\sqrt{(\Sigma L^3)/\Sigma L}$	400.0	400.0 m
Lijnhoek $\beta$	160 °	
Rotatie mast t.o.v. bissectrice $\theta$	0 °	
Vaklengte	400	400 m
Hoogte onderkant mast t.o.v. maaiveld	0.5 m	
Beschouwde windrichtingen	$\alpha_1$	0 °
Windrichtingen volgens:	$\alpha_2$	45 °
Geleiderbelastingen	$\alpha_3$	90 °
	$\alpha_4$	135 °
	$\alpha_5$	80 °
	$\alpha_6$	100 °

Windrichtingen gelden t.o.v. hoofdrichting mastconstructie, niet t.o.v. bissectrice.

Windrichtingen en positieve richtingen belastingen

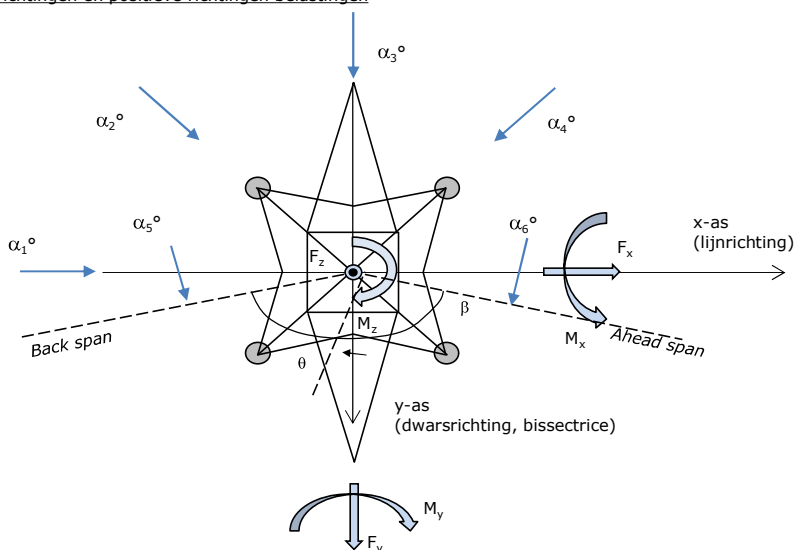

**Beschouwd aantal windrichtingen**

1a	6
3	6
4	1
6	1
Overig	1

Project: RLL-TLB380  
 Tower: HB+6\_c - bouwfase  
 Number: 1079

### Geleiderafval

		SPLS - torsie		SPLS - Enkelzijdige trek		5a - geleiderbreuk	
		Aanw.	Afw.	Aanw.	Afw.	Aanw.	Afw.
Circuit 1	380ct1f1	1	0	1	0	1	0
Circuit 1	380ct1f2	1	0	1	0	1	0
Circuit 1	380ct1f3	1	0	1	0	1	0
Circuit 2	150ct2f1	0	1	1	0	1	0
Circuit 2	150ct2f2	0	1	1	0	1	0
Circuit 2	150ct2f3	0	1	1	0	1	0
Bliksemdraad 1	bl1	1	0	1	0	1	0

### Belastingsituaties SPLS

Beschouwde situaties SPLS: 1 t/m 6, alle mogelijke situaties.

Principe belastingssituaties:

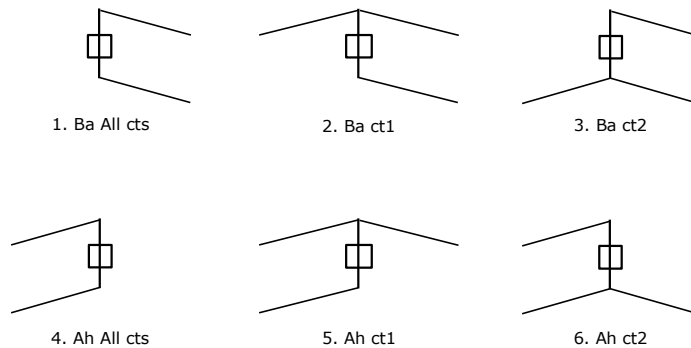

### Belastingsituaties 5a. Geleiderbreuk

Beschouwde situaties geleiderbreuk 5a: 1 en 2, alle mogelijke situaties.

Principe belastingssituaties:

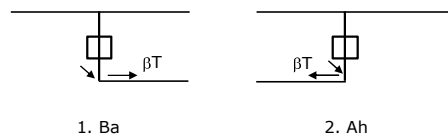

Project: RLL-TLB380  
 Tower: HB+6\_c - bouwfase  
 Number: 1079

### Belastingsituaties 6. Bouw- en onderhoud

Onder 6a wordt de belasting door aanwezigheid lijnwagen of lijnfiets in combinatie met puntlast op traverse in rekening gebracht. Combinatie 6b bevat geen belastingen in geleider of op traverse. Deze combinatie is toegevoegd om te kunnen combineren met separate controle bordessen etc. De situaties worden in ULS en in iedere SPLS-situatie (in geval van hoekmast) toegepast.

	Fase	Bliksem
Lijnwagen	4.0 kN	2.0 kN
Puntlast op traverse	1.0 kN	1.0 kN

Beschouwde situaties bouw- en onderhoud 6a: 1 t/m 4, alle mogelijke situaties.

Aanwezigheid lijnwagen: Circuit, belasting tegelijk aanwezig in alle geleiders per circuit.

Principe belastingssituaties:

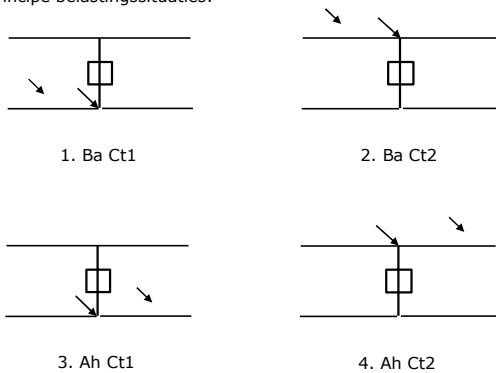

### Belastingsituaties 8. Lijndansen als statische belasting

Geleider		
Steunmast fase	0.866 W	1.5 W
Steunmast bliksem	1.5 EDS	1.5 W
Hoekmast fase en bliksem	1.5 EDS	1.5 W

Beschouwde situaties lijndansen 8: 1 en 2, alle mogelijke situaties.

Belasting tegelijk aanwezig in alle geleiders van het circuit.

Principe belastingssituaties:

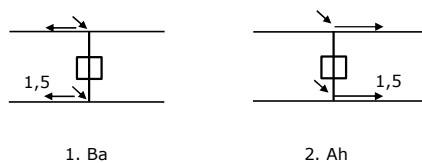

### Belastingcombinatie 8. Lijndansen als dynamische belasting

Alleen van toepassing op hoek- en eindmasten  
 Belasting bestaat uit EDS-trekbelasting in één van de geleiders aan één zijde van de mast  
 Door gebruiker via het belastingsspectrum van tabel 4.11/NL.1 om te zetten naar spanningspectrum

Project: RLL-TLB380  
 Tower: HB+6\_c - bouwfase  
 Number: 1079

## Mastconstructie

### Eigenschappen

Masttype	Hoekmast	
Mastbenaming	HB+6_c - bouwfase	
Voetplaat t.o.v. maaiveld	0.5 m	
Masthoogte t.o.v. voetplaat	59.1 m	
Gewicht mast	1139.9 kN	
<i>Breedte en helling mast bij fundatie</i>		
	x-ri.	y-ri.
Pootsprei	14.04	14.04 m
Helling van de randstijl	0.190	0.190 -
Factor spatkracht	1.1	1.1 -

### Berekening windbelasting

Dynamische invloed $G_T$	1.00 ( <i>Masthoogte &lt; 60 m</i> )
Windbelasting overhoeks op mastlichaam evenredig met:	$(A1C1\sin^2(\phi)+A2C2\cos^2(\phi))$
Windbelasting overhoeks op traverse evenredig met:	$(A1C1\sin^2(\phi)+A2C2\cos^2(\phi))$
Vergroting wind overhoeks mastlichaam	$(1+0,2\sin^2(2\phi))$
Vergroting wind overhoeks traverse	$(1+0,2\sin^2(2\phi))$
Factor wind evenwijdig t.o.v. haaks op traverse	0.4

### Eigenschappen mastsecties langsrichting (vooraanzicht, yz-vlak)

Omschrijving	h [m]	b <sub>1</sub> [m]	b <sub>2</sub> [m]	Δh [m]	Δ <sub>x</sub> [m]	A <sub>0</sub> [m <sup>2</sup> ]	A <sub>1</sub> [m <sup>2</sup> ]	χ = A <sub>1</sub> /A <sub>0</sub> [-]	C <sub>t</sub>
Broekstuk	21.40	14.04	5.91	21.40	0.190	213.49	49.54	0.23	2.79
Eerste tussenstuk	28.20	5.91	5.23	6.80	0.050	37.88	13.54	0.36	2.34
Tweede tussenstuk	34.50	5.23	4.60	6.30	0.050	30.96	9.94	0.32	2.46
Bovenstuk 1	44.00	4.60	3.65	9.50	0.050	39.19	12.67	0.32	2.45
Bovenstuk 2	57.40	3.65	2.31	13.40	0.050	39.93	13.01	0.33	2.45
Topstuk	59.10	2.31		1.70		1.96	0.33	0.17	3.08
Ondertraverse	34.50	9.95		3.10		15.42	4.52	0.29	2.56
Middentraverse	44.00	13.30		3.20		21.28	6.53	0.31	2.51
Boventraverse	54.00	15.68		5.10		39.97	7.67	0.19	2.97

### Eigenschappen mastsecties dwarsrichting (zijaanzicht, xz-vlak)

Omschrijving	h [m]	b <sub>1</sub> [m]	b <sub>2</sub> [m]	Δh [m]	Δ <sub>x</sub> [m]	A <sub>0</sub> [m <sup>2</sup> ]	A <sub>1</sub> [m <sup>2</sup> ]	χ = A <sub>1</sub> /A <sub>0</sub> [-]	C <sub>t</sub>
Broekstuk	21.40	14.04	5.91	21.40	0.190	213.49	49.54	0.23	2.79
Eerste tussenstuk	28.20	5.91	5.23	6.80	0.050	37.88	13.54	0.36	2.34
Tweede tussenstuk	34.50	5.23	4.60	6.30	0.050	30.96	9.94	0.32	2.46
Bovenstuk 1	44.00	4.60	3.65	9.50	0.050	39.19	12.67	0.32	2.45
Bovenstuk 2	57.40	3.65	2.31	13.40	0.050	39.93	13.01	0.33	2.45
Topstuk	59.10	2.31		1.70		1.96	0.33	0.17	3.08
Ondertraverse	34.50	9.95		3.10		15.42	4.52	0.29	2.56
Middentraverse	44.00	13.30		3.20		21.28	6.53	0.31	2.51
Boventraverse	54.00	15.68		5.10		39.97	7.67	0.19	2.97

NB: oppervlakte traverse dwarsrichting van de tabel wordt in berekening gereduceerd.  
 NB: oppervlakte traverse per zijde, dus helft van totaal van twee traverses.

Project: RLL-TLB380  
 Tower: HB+6\_c - bouwfase  
 Number: 1079

#### Windoppervlak feeders telecominstallaties

Onderdeel	A (m <sup>2</sup> /m)	Factor	Δh	A <sub>1</sub>
Broekstuk	0.14	0.71	21.4	2.1
Eerste tussenstuk	0.14	0.71	6.8	0.7
Tweede tussenstuk	0.14	0.71	6.3	0.6
Bovenstuk 1	0.14	0.71	9.5	0.9
Bovenstuk 2				

#### Invoer antennes

Omschrijving	A (m <sup>2</sup> )	h (m)	C <sub>i</sub> (m)
Antenne top			
Antenne o.t.	4.7	40.7	1.5

#### Belastingen mastsectie langsrichting (x-richting) per windrichting

Omschrijving	P <sub>w</sub> [kN/m <sup>2</sup> ]	F <sub>x1</sub> [kN]	F <sub>x2</sub> [kN]	F <sub>x3</sub> [kN]	F <sub>x4</sub> [kN]	h <sub>ef</sub> [m]	M <sub>y1</sub> [kNm]	M <sub>y2</sub> [kNm]	M <sub>y3</sub> [kNm]	M <sub>y4</sub> [kNm]
Broekstuk	0.72	99.4	84.3	0.0	-84.3	10.7	1063.2	902.2	0.0	-902.2
Eerste tussenstuk	0.94	29.7	25.2	0.0	-25.2	24.8	736.1	624.6	0.0	-624.6
Tweede tussenstuk	1.00	24.5	20.8	0.0	-20.8	31.4	767.4	651.2	0.0	-651.2
Bovenstuk 1	1.07	33.2	28.2	0.0	-28.2	39.3	1303.9	1106.4	0.0	-1106.4
Bovenstuk 2	1.14	36.3	30.8	0.0	-30.8	50.7	1837.9	1559.5	0.0	-1559.5
Topstuk	1.18	1.2	1.0	0.0	-1.0	58.3	69.6	59.1	0.0	-59.1
Ondertraverse	1.04	24.0	14.2	0.0	-14.2	35.5	852.1	506.1	0.0	-506.1
Middentraverse	1.10	36.2	21.5	0.0	-21.5	45.1	1632.0	969.4	0.0	-969.4
Boventraverse	1.17	53.1	31.6	0.0	-31.6	55.7	2960.0	1758.2	0.0	-1758.2
<b>Totaal</b>		<b>337.5</b>	<b>257.6</b>	<b>0.0</b>	<b>-257.6</b>		<b>11222.3</b>	<b>8136.6</b>	<b>0.0</b>	<b>-8136.6</b>

#### Belastingen mastsectie dwarsrichting (y-richting) per windrichting

Omschrijving	P <sub>w</sub> [kN/m <sup>2</sup> ]	F <sub>y1</sub> [kN]	F <sub>y2</sub> [kN]	F <sub>y3</sub> [kN]	F <sub>y4</sub> [kN]	h <sub>ef</sub> [m]	M <sub>x1</sub> [kNm]	M <sub>x2</sub> [kNm]	M <sub>x3</sub> [kNm]	M <sub>x4</sub> [kNm]
Broekstuk	0.72	0.0	84.3	99.4	84.3	10.7	0.0	902.2	1063.2	902.2
Eerste tussenstuk	0.94	0.0	25.2	29.7	25.2	24.8	0.0	624.6	736.1	624.6
Tweede tussenstuk	1.00	0.0	20.8	24.5	20.8	31.4	0.0	651.2	767.4	651.2
Bovenstuk 1	1.07	0.0	28.2	33.2	28.2	39.3	0.0	1106.4	1303.9	1106.4
Bovenstuk 2	1.14	0.0	30.8	36.3	30.8	50.7	0.0	1559.5	1837.9	1559.5
Topstuk	1.18	0.0	1.0	1.2	1.0	58.3	0.0	59.1	69.6	59.1
Ondertraverse	1.04	0.0	14.2	9.6	14.2	35.5	0.0	506.1	340.9	506.1
Middentraverse	1.10	0.0	21.5	14.5	21.5	45.1	0.0	969.4	652.8	969.4
Boventraverse	1.17	0.0	31.6	21.3	31.6	55.7	0.0	1758.2	1184.0	1758.2
<b>Totaal</b>		<b>0.0</b>	<b>257.6</b>	<b>269.5</b>	<b>257.6</b>		<b>0.0</b>	<b>8136.6</b>	<b>7955.8</b>	<b>8136.6</b>

#### Resulterende belastingen vanuit mastconstructie incl. antenne zonder geleiders niveau fundatie (kar. waarde)

Belasting / windrichting	F <sub>x</sub> [kN]	F <sub>y</sub> [kN]	F <sub>z</sub> [kN]	M <sub>x</sub> [kNm]	M <sub>y</sub> [kNm]	M <sub>z</sub> [kNm]
Permanente belasting	0	0	1140	0	0	0
Windrichting 0°	345	0	0	0	11531	0
Windrichting 45°	263	263	0	8355	8355	0
Windrichting 90°	0	277	0	8264	0	0
Windrichting 135°	-263	263	0	8355	-8355	0



Project: RLL-TLB380  
 Tower: HB+6\_c - bouwfase  
 Number: 1079

### Tussenresultaten geleiderbelastingen

#### Geleiders back

Circuit	Geleider	Diameter [mm]	A [mm <sup>2</sup> ]	G [N/m]	E [N/mm <sup>2</sup> ]	$\alpha T$ [-]
Circuit 1	AAAC-AL7 620	32.4	621.0	17.71	56000	2.30E-05
Circuit 2	AAAC-AL7 620	32.4	621.0	17.71	56000	2.30E-05
Bliksemdraad 1	AACSR 241-AL3-39-A20SA	21.8	281.0	9.38	70165	1.97E-05

#### Geleiders ahead

Circuit	Geleider	Diameter [mm]	A [mm <sup>2</sup> ]	G [N/m]	E [N/mm <sup>2</sup> ]	$\alpha T$ [-]
Circuit 1	AAAC-AL7 620	32.4	621.0	17.71	56000	2.30E-05
Circuit 2	AAAC-AL7 620	32.4	621.0	17.71	56000	2.30E-05
Bliksemdraad 1	AACSR 241-AL3-39-A20SA	21.8	281.0	9.38	70165	1.97E-05

#### Verticale belasting back

Circuit	Bundel [-]	Toeslag [%]	$W_{z,G}$ [N/m]	IJsgebied	Formule	$W_{z,ijs}$ [N/m]	$W_{z,ijs,bundel}$ [N/m]
Circuit 1	4	3	73.0	B	4+0,2d	10.5	41.9
Circuit 2	2	3	36.5	B	4+0,2d	10.5	21.0
Bliksemdraad 1	1	2	9.6	A	15+0,4d	23.7	23.7

#### Verticale belasting ahead

Circuit	Bundel [-]	Toeslag [%]	$W_{z,G}$ [N/m]	IJsgebied	Formule	$W_{z,ijs}$ [N/m]	$W_{z,ijs,bundel}$ [N/m]
Circuit 1	4	3	73.0	B	4+0,2d	10.5	41.9
Circuit 2	2	3	36.5	B	4+0,2d	10.5	21.0
Bliksemdraad 1	1	2	9.6	A	15+0,4d	23.7	23.7

#### Isolatoren

Geleider	$G_{isolator}$ [kN]	Aantal	$F_{v,iso}$ [kN]	Lengte [m]	Windopp. [m <sup>2</sup> ]	Windhoogte [m]	Stuwdruk [kN/m <sup>2</sup> ]	Vormfactor [-]	$F_{h,iso}$ [kN]
380ct1f1	3.00	1	3	6.5	1.1	54.50	1.16	1.2	1.53
380ct1f2	3.00	1	3	6.5	1.1	44.50	1.10	1.2	1.45
380ct1f3	3.00	1	3	6.5	1.1	35.00	1.03	1.2	1.36
150ct2f1	3.00	1	3	6.5	1.1	54.50	1.16	1.2	1.53
150ct2f2	3.00	1	3	6.5	1.1	44.50	1.10	1.2	1.45
150ct2f3	3.00	1	3	6.5	1.1	35.00	1.03	1.2	1.36
bl1	0.10	1	0.1	0.2	0.1	59.60	1.19	1.2	0.14

Project: RLL-TLB380  
 Tower: HB+6\_c - bouwfase  
 Number: 1079

#### Windbelasting back

Geleider	hoogte		$G_{c,dwars}$	$G_{c,trek}$	$C_c$	$d_{toeslag}$	$W_y$	$W_{y,vak}$	$D_{jjs,toeslag}$	$W_{y,ijs}$	$W_{y,ijs,vak}$
	wind [m]	Stuwdruk [kN/m <sup>2</sup> ]									
380ct1f1	53.1	1.15	0.62	0.68	0.95	33.37	91.4	100.4	51.8	178.5	196.2
380ct1f2	43.1	1.09	0.61	0.67	0.97	33.37	85.9	94.5	51.8	164.5	181.0
380ct1f3	33.6	1.02	0.59	0.65	1.00	33.37	79.5	87.5	51.8	148.8	163.8
150ct2f1	53.1	1.15	0.62	0.68	0.95	33.37	45.7	50.2	51.8	89.2	98.1
150ct2f2	43.1	1.09	0.61	0.67	0.97	33.37	42.9	47.2	51.8	82.3	90.5
150ct2f3	33.6	1.02	0.59	0.65	1.00	33.37	39.7	43.7	51.8	74.4	81.9
bl1	58.2	1.18	0.63	0.69	1.18	22.24	19.4	21.3	63.1	56.3	61.8

#### Windbelasting ahead

Geleider	hoogte		$G_{c,dwars}$	$G_{c,trek}$	$C_c$	$d_{toeslag}$	$W_y$	$W_{y,vak}$	$D_{jjs,toeslag}$	$W_{y,ijs}$	$W_{y,ijs,vak}$
	wind [m]	Stuwdruk [kN/m <sup>2</sup> ]									
380ct1f1	50.1	1.14	0.62	0.68	0.96	33.37	89.8	98.8	51.8	174.5	191.9
380ct1f2	40.1	1.07	0.60	0.66	0.98	33.37	84.0	92.4	51.8	159.9	175.9
380ct1f3	30.6	0.99	0.58	0.64	1.00	33.37	77.1	84.9	51.8	143.2	157.6
150ct2f1	50.1	1.14	0.62	0.68	0.96	33.37	44.9	49.4	51.8	87.3	95.9
150ct2f2	40.1	1.07	0.60	0.66	0.98	33.37	42.0	46.2	51.8	79.9	88.0
150ct2f3	30.6	0.99	0.58	0.64	1.00	33.37	38.6	42.4	51.8	71.6	78.8
bl1	55.2	1.17	0.62	0.69	1.18	22.24	19.1	21.0	63.1	55.2	60.6

NB: belastingen  $w_v$  gelden voor bundel

Project: RLL-TLB380  
 Masttype: HB+6\_c - bouwfase  
 Mast: 1079

Auteur: TBR  
 Versie: v12.0

### Geleiderbelastingen

#### Uitgangspunten

Betrouwbaarheidsniveau Nieuwbouw CC2  
 Referentieperiode 15 jaar

ULS (bezwijksterkte)		NEN-EN50341-2-15:2019							
Belastingsgeval	omschrijving	Temp °C	$\gamma_G$		$\gamma_Q$			$\gamma_a$ $A_k$	
			$G_{k,mast}$	$G_{k,geleider}$	$Q_{pk}$	$Q_{wk}$	$Q_{ik}$		
ULS 1a	Wind	10°	1.20	1.20	0.00	1.25	0.00	0.0	
ULS 1a_0,9	Wind 0,9Gk alleen mast	10°	0.90	1.20	0.00	1.25	0.00	0.0	
ULS 1a_0,9_0,9	Wind 0,9Gk ook geleider	10°	0.90	0.90	0.00	1.25	0.00	0.0	
ULS 3	Wind+ijs	-5°	1.20	1.20	0.00	0.38	1.07	0.0	
ULS 3_0,9	Wind+ijs 0,9	-5°	0.90	1.20	0.00	0.38	1.07	0.0	
ULS 4	Koude+wind	-20°	1.20	1.20	0.00	0.25	0.00	0.0	
ULS 4_0,9	Koude+wind 0,9	-20°	0.90	1.20	0.00	0.25	0.00	0.0	
ULS 5a	Torsiebelastingen	10°	1.00	1.00	1.00	0.00	0.00	1.0	
ULS 5b	Longitudinale belastingen	10°	1.00	1.00	0.00	0.00	0.00	1.0	
ULS 6	Bouw en onderhoud	5°	1.20	1.20	1.50	0.25	0.00	0.0	
ULS 6_0,9	Bouw en onderhoud	5°	1.20	1.20	0.00	0.25	0.00	0.0	
ULS 7	Permanent	10°	1.35	1.35	0.00	0.00	0.00	0.0	
ULS 8	Special	10°	1.00	1.00	0.00	0.00	0.00	1.0	
<b>SPLS</b> (Bezwijksterkte, enkel voor hoekmasten: afwezigheid geleiders)			$\gamma_G$		$\gamma_Q$				
			$G_k$	$G_k$	$Q_{pk}$	$Q_{wk}$	$Q_{ik}$	$A_k$	
SPLS 1a	Wind	10°	1.20	1.20	0.0	0.78	0.00	0.0	
SPLS 1a_0,9	Wind 0,9	10°	0.90	1.20	0.0	0.78	0.00	0.0	
SPLS 1a_0,9_0,9	Wind 0,9	10°	0.90	0.90	0.0	0.78	0.00	0.0	
SPLS 3	Wind+ijs	-5°	1.20	1.20	0.0	0.36	0.34	0.0	
SPLS 3_0,9	Wind+ijs 0,9	-5°	0.90	1.20	0.0	0.36	0.34	0.0	
SPLS 4	Koude+wind	-20°	1.20	1.20	0.0	0.24	0.00	0.0	
SPLS 4_0,9	Koude+wind 0,9	-20°	0.90	1.20	0.0	0.24	0.00	0.0	
SPLS 6	Bouw en onderhoud	5°	1.20	1.20	1.2	0.24	0.0	0.0	
SPLS 6_0,9	Bouw en onderhoud	5°	1.20	1.20	0.0	0.24	0.0	0.0	
<b>SLS</b> (controle van de vervormingen, vermoeiing, EDS)			$G_k$		$Q_{pk}$	$Q_{wk}$	$Q_{ik}$	$A_k$	
SLS 1a	Wind	10°	1.00	1.00	0.0	0.87	0.0	0.0	
SLS 3	Wind+ijs	-5°	1.00	1.00	0.0	0.26	0.71	0.0	
SLS 4	Wind	-20°	1.00	1.00	0.0	0.17	0.0	0.0	
SLS 6	Bouw en onderhoud	5°	1.00	1.00	0.0	0.17	0.0	0.0	
SLS 7	PB (EDS, geen wind)	10°	1.00	1.00	0.0	0.00	0.0	0.0	

Aantal windrichtingen 6  
 Aantal belastingcombinaties ULS 68  
 Aantal belastingcombinaties SPLS 222  
 Aantal belastingcombinaties SLS 15  
 Aantal knooplasten 5185

Project: RLL-TLB380  
 Masttype: HB+6\_c - bouwfase  
 Mast: 1079

### Samenvattingstabellen geleiderbelastingen

In de onderstaande vier tabellen is weergegeven:

- De maximale geleiderbelasting in het globale assenstelsel, gesplitst in aandeel van back en ahead span
- De gecombineerde geleiderbelasting (Ba+Ah) in het globale assenstelsel met in het lokale assenstelsel de maximaal optredende trekkracht. Componenten Fx en Fy als absolute waarde
- De alledaagse (EDS) waarden van de gecombineerde geleiderbelastingen (Ba+Ah) met bijbehorende trekkrachten
- Controle op uplift, waar een negatieve waarde duidt op uplift

#### Maximale waarden voor back en ahead span

Geleider	Fx_ba [kN]	Fx_ah [kN]	Fy_ba [kN]	Fy_ah [kN]	Fz_ba [kN]	Fz_ah [kN]
bl1	-54.0	53.8	13.9	13.7	8.2	8.2
380ct1f1	-239.7	238.8	65.4	64.7	35.6	35.6
380ct1f2	-236.6	235.7	62.8	61.9	35.5	35.5
380ct1f3	-233.4	232.4	59.8	58.7	35.5	35.4
Post-isolato	0.0	0.0	0.0	0.0	0.0	
Post-isolato	0.0	0.0	0.0	0.0	0.0	
Post-isolato	0.0	0.0	0.0	0.0	0.0	
150ct2f1	-119.8	119.3	33.7	33.3	22.5	22.5
150ct2f2	-118.3	117.8	32.4	31.9	22.5	22.5
150ct2f3	-116.7	116.1	30.8	30.3	22.5	22.5

#### Min. Weight span (m)

Weight spar Combinatie1

Geleider	SLS 1a	SLS 4	SLS 7
bl1	481.1	496.9	481.0
380ct1f1	481.0	496.0	481.0
380ct1f2	481.0	495.8	481.0
380ct1f3	481.0	495.5	481.0
Post-isolator 1			
Post-isolator 2			
Post-isolator 3			
150ct2f1	481.0	496.0	481.0
150ct2f2	481.0	495.8	481.0
150ct2f3	481.0	495.5	481.0

#### Max. Weight span (m)

Weight spar Combinatie1

Geleider	ULS 1a	ULS 3
bl1	558.6	472.2
380ct1f1	519.0	482.9
380ct1f2	515.3	481.9
380ct1f3	511.0	480.7
Post-isolator 1		
Post-isolator 2		
Post-isolator 3		
150ct2f1	519.0	482.9
150ct2f2	515.3	481.9
150ct2f3	511.0	480.7

Omhullende weight span over alle combinaties (incl. 0,9 combinaties)

Voor alle geleiders

	Max. weight span	Min. weight span	Wind / Weight span verhouding
	558.6 m	194.1 m	1.396 -
			0.485 -

Project: RLL-TLB380  
 Masttype: HB+6\_c - bouwfase  
 Mast: 1079

**Maximale waarden back+ahead span      Maximale waarden trekkracht geleider**

Geleider	Maximale waarden back+ahead span		Maximale waarden trekkracht geleider		
	Fx [kN]	Fy [kN]	Fz [kN]	Ft_ba [kN]	Ft_ah [kN]
bl1	39.2	27.2	8.2	-55.6	55.3
380ct1f1	206.9	127.4	35.6	-245.8	244.9
380ct1f2	203.1	122.2	35.5	-242.6	241.5
380ct1f3	199.0	116.1	35.5	-239.1	237.9
Post-isolato	3.7	3.7	6.8	0.0	
Post-isolato	2.8	2.8	4.7	0.0	
Post-isolato	4.2	4.2	6.8	0.0	
150ct2f1	108.3	65.5	22.5	-122.9	122.4
150ct2f2	108.2	63.0	22.5	-121.3	120.8
150ct2f3	108.1	59.9	22.5	-119.6	119.0

**EDS-belastingen geleiders**

Geleider	Fx	Fy	Fz	Ft_ba	Ft_ah
	[kN]	[kN]	[kN]	[kN]	[kN]
bl1	17.0	3.0	2.4	-17.2	17.2
380ct1f1	129.3	22.8	20.5	-131.3	131.3
380ct1f2	129.3	22.8	20.5	-131.3	131.3
380ct1f3	129.3	22.8	20.5	-131.3	131.3
Post-isolato	0.0	0.0	5.0	0.0	
Post-isolato	0.0	0.0	3.5	0.0	
Post-isolato	0.0	0.0	5.0	0.0	
150ct2f1	64.7	11.4	11.8	-65.7	65.7
150ct2f2	64.7	11.4	11.8	-65.7	65.7
150ct2f3	64.7	11.4	11.8	-65.7	65.7

**Controle uplift SLS-wind**

Combinatie: Geleider	Fz_ba	Fz_ah
	[kN]	[kN]
SLS 4 bl1	0.0	0.0
380ct1f1	0.0	0.0
380ct1f2	0.0	0.0
380ct1f3	0.0	0.0
Post-isolato	0.0	
Post-isolato	0.0	
Post-isolato	0.0	
150ct2f1	0.0	0.0
150ct2f2	0.0	0.0
150ct2f3	0.0	0.0

Project: RLL-TLB380  
 Masttype: HB+6\_c - bouwfase  
 Mast: 1079

**ULS-fundatiebelasting combinatie 1 en 3 wind haaks op de lijn of bissectrice en EDS, vanuit geleiders**

Combinatie	Combination	$F_x$ [kN]	$F_y$ [kN]	$F_z$ [kN]	$M_x$ [kNm]	$M_y$ [kNm]	$M_z$ [kNm]
ULS 1a_90		-11	588	269	24099	-470	115
ULS 1a_0.9_0		12	245	186	9296	529	126
ULS 1a_0.9_0.9_90		-12	565	122	24500	-528	130
ULS 3_0		4	364	359	12930	173	35
SLS 7		0	211	212	7536	0	0

**ULS-fundatiebelasting combinatie 1 en 3 wind haaks op de lijn of bissectrice en EDS, totaal geleiders en mast**

Combinatie	$F_x$ [kN]	$F_y$ [kN]	$F_z$ [kN]	$M_x$ [kNm]	$M_y$ [kNm]	$M_z$ [kNm]
ULS 1a_90	-11	936	1637	34455	-470	115
ULS 1a_0.9_0.9_90	-12	912	1148	34855	-528	130
SLS 7	0	211	1352	7536	0	0

**Fundatiebelastingen, selectie belastingcombinaties op basis grootste waarde**

Combinatie	$F_x$ [kN]	$F_y$ [kN]	$F_z$ [kN]	$M_x$ [kNm]	$M_y$ [kNm]	$M_z$ [kNm]
ULS 1a_0.9_90	-11	936	1196	<b>35408</b>	-470	115
SPLS 3_90 Ah All Cts	-946	305	1544	10763	<b>-42466</b>	10091
SPLS 3_80 Ah All Cts	-934	308	1544	10901	-42207	<b>10168</b>
SPLS 1a_0.9_90 Ah All Cts	-844	448	1137	<b>16025</b>	<b>-37812</b>	8968

*Noot: grootste waarden kunnen in meerdere combinaties voorkomen, een combinatie is weergegeven.*

**Oplegreacties op fundering per randstijl**

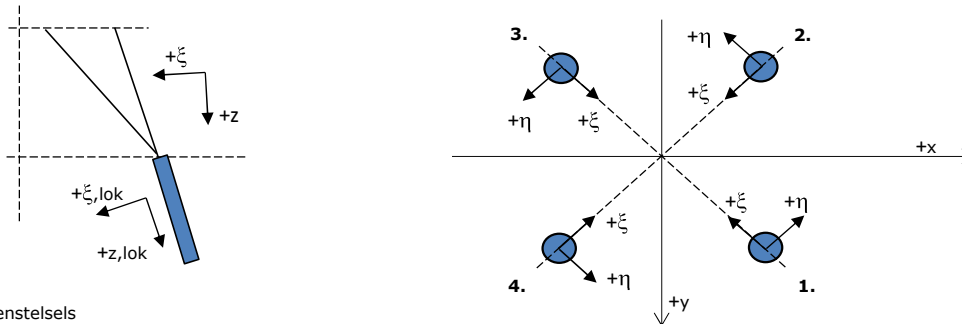

Assenstelsels

**Maximale drukbelasting**

Stijl	Combinatie	$R_x$ [kN]	$R_y$ [kN]	$R_z$ [kN]	$R_\eta$ [kN]	$R_\xi$ [kN]	$R_{\xi,lok}$ [kN]	$R_{z,lok}$ [kN]
1	SPLS 1a_90 Ba All Cts	246	629	<b>2271</b>	-271	-619	-9	2352
2	SPLS 3_0 Ba All Cts	439	-196	<b>1678</b>	-172	-449	2	1737
3	ULS 8 Ba	-433	-161	<b>1613</b>	192	-420	13	1670
4	SPLS 1a_90 Ah All Cts	-247	633	<b>2284</b>	273	-622	-9	2365

**Maximale trekbelasting**

Stijl	Combinatie	$R_x$ [kN]	$R_y$ [kN]	$R_z$ [kN]	$R_\eta$ [kN]	$R_\xi$ [kN]	$R_{\xi,lok}$ [kN]	$R_{z,lok}$ [kN]
1	ULS 8 Ba	50	-356	<b>-921</b>	287	216	-32	-954
2	SPLS 1a_0.9_90 Ah All Cts	-430	174	<b>-1633</b>	181	428	-11	-1691
3	SPLS 1a_0.9_90 Ba All Cts	425	172	<b>-1612</b>	-179	423	-11	-1669
4	SPLS 3_0.9_0 Ba All Cts	-17	-367	<b>-992</b>	-272	247	-19	-1027

**Maximale torsiebelasting (positief)**

Stijl	Combinatie	$R_x$ [kN]	$R_y$ [kN]	$R_z$ [kN]	$R_\eta$ [kN]	$R_\xi$ [kN]	$R_{\xi,lok}$ [kN]	$R_{z,lok}$ [kN]
1	SPLS 3_0.9_80 Ah All Cts	92	-358	-811	<b>318</b>	188	-30	-839
2	SPLS 3_0.9_80 Ah All Cts	-439	150	-1622	<b>205</b>	417	-19	-1679
3	SPLS 3_80 Ah All Cts	-414	-137	1501	<b>196</b>	-389	14	1554
4	SPLS 3_80 Ah All Cts	-214	653	2277	<b>310</b>	-613	-1	2358

**Maximale torsiebelasting (negatief)**

Index	Combinatie	$R_x$ [kN]	$R_y$ [kN]	$R_z$ [kN]	$R_\eta$ [kN]	$R_\xi$ [kN]	$R_{\xi,lok}$ [kN]	$R_{z,lok}$ [kN]
1	SPLS 3_100 Ba All Cts	213	649	2265	<b>-308</b>	-610	-1	2345
2	SPLS 3_100 Ba All Cts	412	-136	1494	<b>-195</b>	-388	14	1547
3	SPLS 3_0.9_100 Ba All Cts	434	148	-1601	<b>-202</b>	412	-18	-1657
4	SPLS 3_0.9_100 Ba All Cts	-92	-355	-806	<b>-316</b>	186	-30	-834

Project: RLL-TLB380  
 Masttype: HB+6\_c - bouwfase  
 Mast: 1079

#### Combinatie Ftrek+Fhor

Stijl	Combinatie	R <sub>x</sub> [kN]	R <sub>y</sub> [kN]	R <sub>z</sub> [kN]	R <sub>η</sub> [kN]	R <sub>ξ</sub> [kN]	R <sub>ξ,lok</sub> [kN]	R <sub>z,lok</sub> [kN]
1	ULS 8 Ba	50	-356	<b>-921</b>	<b>287</b>	216	-32	-954
2	SPLS 3_0.9_80 Ah All Cts	-439	150	<b>-1622</b>	<b>205</b>	417	-19	-1679
3	SPLS 3_0.9_90 Ba All Cts	435	151	<b>-1605</b>	<b>-201</b>	414	-17	-1662
4	SPLS 3_0.9_0 Ba All Cts	-17	-367	<b>-992</b>	<b>-272</b>	247	-19	-1027

#### Permanente belasting

Stijl	Combinatie	R <sub>x</sub> [kN]	R <sub>y</sub> [kN]	R <sub>z</sub> [kN]	R <sub>η</sub> [kN]	R <sub>ξ</sub> [kN]	R <sub>ξ,lok</sub> [kN]	R <sub>z,lok</sub> [kN]
1	SLS 7	127	123	606	2	-177	-14	628
2	SLS 7	15	-18	70	2	-23	-4	72
3	SLS 7	-15	-18	70	-2	-23	-4	72
4	SLS 7	-127	123	606	-2	-177	-14	628

#### Omhullenden ongeacht stijl

Belasting	Combinatie	R <sub>x</sub> [kN]	R <sub>y</sub> [kN]	R <sub>z</sub> [kN]	R <sub>η</sub> [kN]	R <sub>ξ</sub> [kN]	R <sub>ξ,lok</sub> [kN]	R <sub>z,lok</sub> [kN]
Max. druk	SPLS 1a_90 Ah All Cts	-247	633	<b>2284</b>	273	-622	-9	2365
Max. trek	SPLS 1a_0.9_90 Ah All Cts	-430	174	<b>-1633</b>	181	428	-11	-1691
Max. pos. torsie	SPLS 3_0.9_80 Ah All Cts	92	-358	-811	<b>318</b>	188	-30	-839
Max. neg. torsie	SPLS 3_0.9_100 Ba All Cts	-92	-355	-806	<b>-316</b>	186	-30	-834
Comb. trek+torsie	SPLS 3_0.9_80 Ah All Cts	-439	150	<b>-1622</b>	<b>205</b>	417	-19	-1679

#### Maximale trekbelasting SLS

Stijl	Combinatie	R <sub>x</sub> [kN]	R <sub>y</sub> [kN]	R <sub>z</sub> [kN]	R <sub>η</sub> [kN]	R <sub>ξ</sub> [kN]	R <sub>ξ,lok</sub> [kN]	R <sub>z,lok</sub> [kN]
1	SPLS 3_0.9_90 Ah All Cts	87	-360	<b>-825</b>	316	193	-29	-854
2	SPLS 1a_0.9_90 Ah All Cts	-430	174	<b>-1633</b>	181	428	-11	-1691
3	SPLS 1a_0.9_90 Ba All Cts	425	172	<b>-1612</b>	-179	423	-11	-1669
4	SPLS 3_0.9_0 Ba All Cts	-17	-367	<b>-992</b>	-272	247	-19	-1027

#### Maximale drukbelasting SLS

Stijl	Combinatie	R <sub>x</sub> [kN]	R <sub>y</sub> [kN]	R <sub>z</sub> [kN]	R <sub>η</sub> [kN]	R <sub>ξ</sub> [kN]	R <sub>ξ,lok</sub> [kN]	R <sub>z,lok</sub> [kN]
1	SPLS 1a_0.9_90 Ba All Cts	228	610	<b>2187</b>	-270	-593	-5	2264
2	SPLS 3_0.9_0 Ba All Cts	417	-176	<b>1573</b>	-170	-419	3	1629
3	SPLS 3_100 Ah All Cts	-415	-144	<b>1513</b>	192	-395	12	1566
4	SPLS 1a_100 Ah All Cts	-253	628	<b>2278</b>	265	-623	-11	2358

Project: RLL-TLB380  
Masttype: HB+6\_c - bouwfase  
Mast: 1079

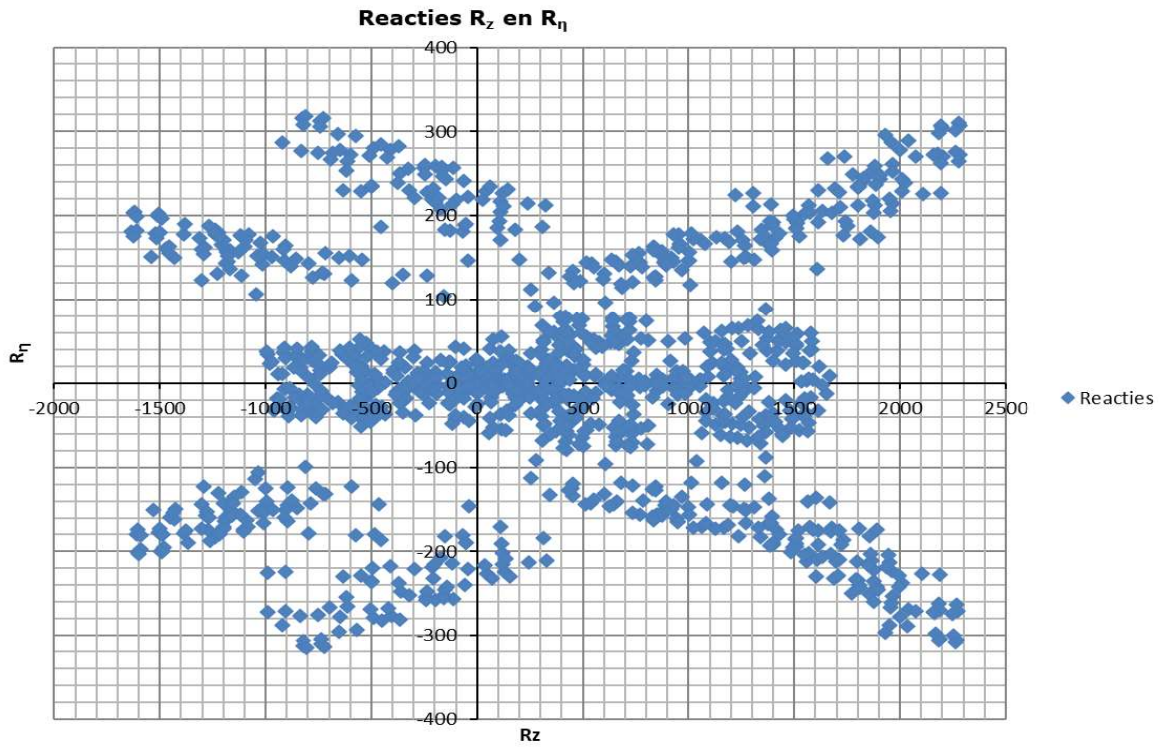



## Belastinggeval - afspannen

Date: 2021-05-21  
 Author: TBR  
 Version: 1.1

RLL-TLB  
 HB+6\_c (afspannen)

### Invoergegevens

#### **Hoogteafwijking mastbeeld naastgelegen masten en richtingsverandering t.o.v. Lijnrichting**

Circuits	Aanduiding	Nummer	Hoogteverschil		Richtingsverandering	
			Dh_back	Dh_ahead	Dy_back	Dy_ahead
Circuit 1	10	380ct1f1	0,0	-9,0 m	0,0	0,0 m
Circuit 1	11	380ct1f2	0,0	-9,0 m	0,0	0,0 m
Circuit 1	12	380ct1f3	0,0	-9,0 m	0,0	0,0 m
Circuit 2	40	380ct2f1	-54,0	0,0 m	0,0	0,0 m
Circuit 2	41	380ct2f2	-44,0	0,0 m	0,0	0,0 m
Circuit 2	42	380ct2f3	-34,5	0,0 m	0,0	0,0 m
Circuit 3	20	150ct3f1	0,0	-9,0 m	0,0	0,0 m
Circuit 3	21	150ct3f2	0,0	-9,0 m	0,0	0,0 m
Circuit 3	22	150ct3f3	0,0	-9,0 m	0,0	0,0 m
Circuit 4	30	150ct4f1	-54,0	0,0 m	0,0	0,0 m
Circuit 4	31	150ct4f2	-44,0	0,0 m	0,0	0,0 m
Circuit 4	32	150ct4f3	-34,5	0,0 m	0,0	0,0 m
Bliksemdraad 1	1	bl1	0,0	-9,0 m	0,0	0,0 m
Bliksemdraad 2	3	bl2	-59,1	0,0 m	0,0	0,0 m

### **Lijn- en mastgegevens**

		Back	Ahead
Ruling span $\sqrt{(SL3/SL)}$		82,5	400,0 m
Lijnhoek	$\beta$	180 °	
Rotatie mast t.o.v. bissectrice	$\theta$	-20 °	
Vaklengte		83	400 m
Hoogte onderkant mast t.o.v. maaiveld		0,5 m	
Beschouwde windrichtingen	a1	0 °	
Windrichtingen volgens:	a2	45 °	
<i>Geleiderbelastingen</i>	a3	90 °	
	a4	135 °	
	a5	110 °	
	a6	110 °	

*Windrichtingen gelden t.o.v. hoofdrichting mastconstructie, niet t.o.v. bissectrice.*

In onderstaande tabel zijn de optredende belastingen weergegeven, voor deze situatie geldt:

- belasting op geleider1, 10 t/m 12 en 20 t/m 22 zijn permanent aanwezig
- van de belasting op de overige geleiders is er telkens één aanwezig per belastingcombinatie

### Uitvoer geleiderbelastingen

Belastingcombi	nummer	Fxtotaal	Fytotaal	Fztotaal	Ftrekahead	Ftrekback
<b>ULS 6b_90</b>	1	<b>20,0</b>	<b>8,2</b>	<b>3,4</b>	21,6	0,0
	10	<b>147,9</b>	<b>58,6</b>	<b>28,3</b>	159,0	0,0
	11	<b>147,5</b>	<b>58,1</b>	<b>28,2</b>	158,5	0,0
	12	<b>147,1</b>	<b>57,6</b>	<b>28,2</b>	157,9	0,0
	20	<b>73,9</b>	<b>29,4</b>	<b>14,7</b>	79,5	0,0
	21	<b>73,7</b>	<b>29,1</b>	<b>14,7</b>	79,2	0,0
	22	<b>73,5</b>	<b>28,9</b>	<b>14,7</b>	79,0	0,0
	40	<b>-141,0</b>	<b>-50,2</b>	<b>121,5</b>	0,0	-149,7
	41	<b>-141,0</b>	<b>-50,2</b>	<b>103,3</b>	0,0	-149,6
	42	<b>-140,9</b>	<b>-50,2</b>	<b>86,1</b>	0,0	-149,5
	30	<b>-70,6</b>	<b>-25,0</b>	<b>61,4</b>	0,0	-74,8
	31	<b>-70,5</b>	<b>-25,0</b>	<b>52,3</b>	0,0	-74,8
	32	<b>-70,5</b>	<b>-25,0</b>	<b>43,6</b>	0,0	-74,8
	3	<b>-18,6</b>	<b>-6,6</b>	<b>16,8</b>	0,0	-19,7



## **APPENDIX B**

### **Resultaten PLS-TOWER**

---

Deze Appendix bevat de resultaten uit PLS-TOWER voor de verschillende masttypen. De samenstelling van de bovenstukken zijn voor alle masttypen gelijk. De resultaten van het bovenstuk zijn dan ook alleen opgenomen van het maatgevende masttype HB+6/c. De resultaten van het onderstuk zijn voor alle masten opgenomen.

Resultaten opgenomen voor:

- Masttype HB+0/c
- Masttype HB+6/c

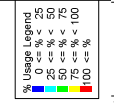
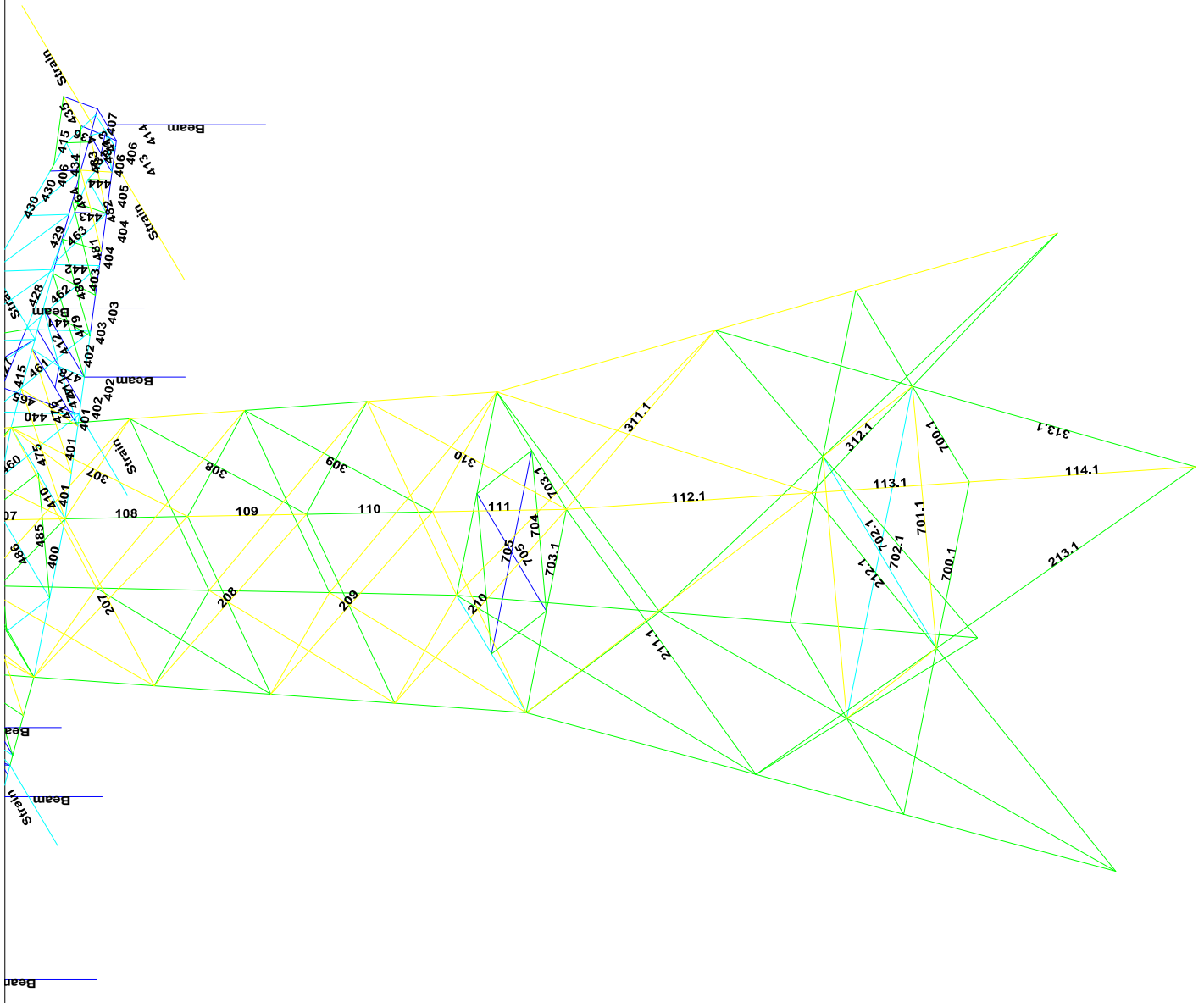



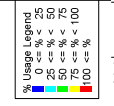
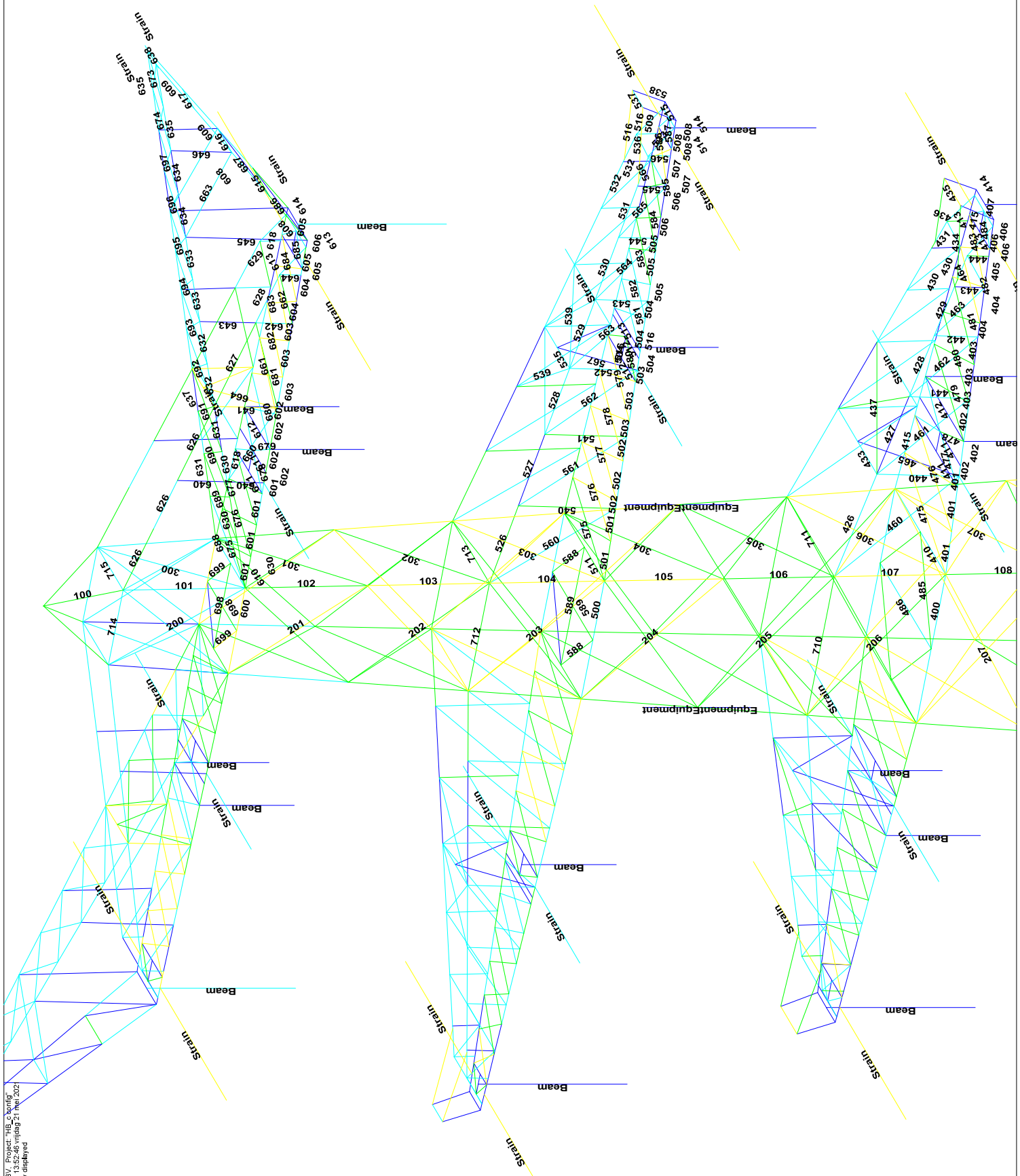









Assessment of angle groups - Tower top

Date  
Author  
Version

16-7-2021  
MRE  
1.0

RLI-TBG  
HB+6\_C

Group Label	Description	Type	Profile	Steel Qual	Bolts	#sh-p1	L2	p1	RLX	RLY	RLZ	Slenderness	Compression	Lead Case (Compression)	Buckling	Shear (Comp) (ring (Comp))	U.C. (Comp) (ring (Comp))	Tension	Lead Case (Tension)	Net section (ring (Tens))	U.C. (Tens) (ring (Tens))
696	Earth peak disp upper plane	EA	60x60x6	S355	M16-8.8	1	35	25	0.54	0.54	0.54	87	-17.6	S15 S 3.00 All Cts. 160g	111.6	60.3	76.6	17.2	S15 S 3.00 All Cts. 160g	66.3	53.4
697	Earth peak disp lower plane	EA	150x150x12	S355	40x24-8.8	1	55	40	1.00	1.00	1.00	58	-55.6	S15 S 3.00 EA All Cts. 160g	888.9	542.2	846.7	54.7	S15 S 3.00 EA All Cts. 160g	75.3	58.4
698	Wind bracing top ca.	EA	150x150x12	S355	40x24-8.8	1	55	40	1.00	1.00	1.00	58	-55.6	S15 S 3.00 EA All Cts. 160g	888.9	542.2	846.7	54.7	S15 S 3.00 EA All Cts. 160g	75.3	58.4
699	Wind bracing top ca.	EA	150x150x12	S355	40x24-8.8	1	55	40	1.00	1.00	1.00	58	-55.6	S15 S 3.00 EA All Cts. 160g	888.9	542.2	846.7	54.7	S15 S 3.00 EA All Cts. 160g	75.3	58.4
710	Horizontal top of mid ca.	EA	150x150x10	S355	20x24-8.8	1	55	40	1.00	1.00	1.00	182	-137.4	U.S. 3.00 EA All Cts. 160g	176.2	271.1	352.6	13.1	U.S. 3.00 EA All Cts. 160g	379.9	271.1
711	Horizontal top of lower ca.	EA	150x150x10	S355	20x24-8.8	1	55	40	1.00	1.00	1.00	182	-137.4	U.S. 3.00 EA All Cts. 160g	176.2	271.1	352.6	13.1	U.S. 3.00 EA All Cts. 160g	379.9	271.1
712	Horizontal top of mid ca.	EA	150x150x12	S355	40x24-8.8	1	55	40	1.00	1.00	1.00	142	-95.6	S15 S 3.00 All Cts. 160g	228.8	542.2	846.7	16.6	S15 S 3.00 All Cts. 160g	522.0	462.2
713	Horizontal top of lower ca.	EA	150x150x12	S355	40x24-8.8	1	55	40	1.00	1.00	1.00	142	-95.6	S15 S 3.00 All Cts. 160g	228.8	542.2	846.7	16.6	S15 S 3.00 All Cts. 160g	522.0	462.2
714	Horizontal top of top ca.	EA	150x150x12	S355	40x24-8.8	1	55	40	1.00	1.00	1.00	98	-17.7	S15 S 3.00 EA All Cts. 160g	352.6	542.2	846.7	10.9	U.S. 3.00 EA All Cts. 160g	522.0	462.2
715	Horizontal top of top ca.	EA	150x150x10	S355	20x24-8.8	1	55	40	1.00	1.00	1.00	152	-18.7	U.S. 3.00 EA All Cts. 160g	352.6	271.1	352.6	11.1	U.S. 3.00 EA All Cts. 160g	305.3	271.1







Project: ZW-Oost  
Mast: H\_C

### Angle check

NEN-EN1993-1-1 and EN1993-3-1

Datum: 2021-05-26  
Auteur: TBR  
Versie: 3.0

Member name	Group 108-109	Conclusion
Section	XEA 200x200x24	U.C. (compression) <b>0.78 &lt; 1,0 OK</b>
		U.C. (tension) <b>0.53 &lt; 1,0 OK</b>

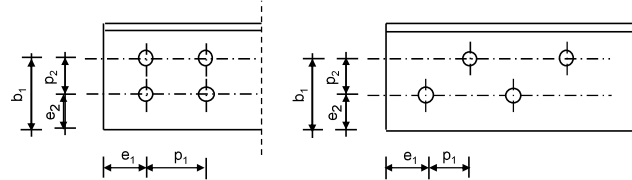
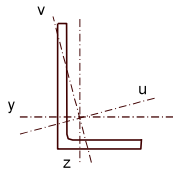

Steel grade **S355**

#### Member loads

Compressive force  $N_{Ed} =$  **4098 kN**  
Tensile force **-3656 kN**

#### Crossing diagonal loads

Applicable: **No**  
Min. tensile force diagonal 2 **1 kN**  
Max. comp. force diagonal 1 **1 kN**  
Position crossing diagonal y-axis **1.00 m**

#### Construction loads

Vertical construction load **1.0 kN**  
Member angle to horizontal **0 °**  
Bending around axis **y-axis**

#### Geometry

System length y-axis  $L_{y,buc} =$  **1.66 m**  
System length z-axis  $L_{z,buc} =$  **1.66 m**  
System length v-axis  $L_{v,buc} =$  **1.66 m**  
System length x-axis  $L_{tk,buc} =$  **1.66 m**  
Member type **Leg**  
Type bracing **Non staggered**

#### End conditions

Begin **Continuous**  
End **Continuous**  
Restraint code TOWER **C4**

#### Bolted connection

Bolt type **M24**  
Bolt class **8.8**  
Number of bolts per leg **6** (24 total)  
Shearplane through **Thread**  
Bolt pattern **Zigzag**  
Bolt pattern (leg-member only) **Staggered**

End distance  $e_1 =$  **55 mm** **Ok**  
Separation distance //  $p_1 =$  **70 mm** **Ok**  
Separation distance |  $p_2 =$  **100 mm** **Ok**  
End distance  $e_2 =$  **50 mm** **Ok**  
Double strap or single strap **Double**  
Tie plate  $b_p =$  **230 mm** **OK**  
 $t_p =$  **15 mm** **OK**  
 $e_2 =$  **40 mm** **OK**

A **18118 mm<sup>2</sup>**  
G **144.9 kg/m**  
Partial safety factor  $\gamma_{f;Q} =$  **1.50**  
Material factors  $\gamma_{M0} =$  **1.00**  
 $\gamma_{M1} =$  **1.00**  
 $\gamma_{M2} =$  **1.25**  
Shear strength bolt  $F_{v;b;Rd} =$  **135.6 kN**

Slenderness  $\lambda_{max} = L / i :$  **22 -**  
Allowed: **120** **OK**

#### Bending due to vertical construction load

$M_{y,Ed} = 1/4 F_{Ed} L_{pr} =$  **0.62 kNm**  
U.C. = **0.00 < 1,00 OK**

#### Results stability

	$\lambda_{eff,rel}$	$\lambda_{eff}$	$\lambda_{eff,mod}$	$\chi_{buc}$	$\eta$	$N_{b,Rd} = \eta \chi A_f \gamma / \gamma_{M1}$
$L_{y,buc} =$ 1.66 m	0.26	1,00 I	0.26	0.98	1	6299 <b>0.65</b>
$L_{z,buc} =$ 1.66 m	0.26	1,00 I	0.26	0.98	1	6299 <b>0.65</b>
$L_{v,buc} =$ 1.66 m	0.28	0,10+0,80 I	0.28	0.97	1	6237 <b>0.66</b>
$L_{tk,buc} =$ 1.66 m	0.55			0.81	1	5229 <b>0.78</b>

#### Bolted connection

Compression	$F_{Rd}$ (kN)	U.C.	Tension	$F_{Rd}$ (kN)	U.C.
Cross section angle	$F_{u;Rd} =$ 6432	<b>0.64</b>	Net section angle	$F_{u;Rd} =$ 6987	<b>0.52</b>
Cross section tie plate	$F_{u;Rd} =$ 8094	<b>0.51</b>	Net section tie plate	$F_{u;Rd} =$ 6943	<b>0.53</b>
Shear strength	$F_{v;Rd} =$ 8675	<b>0.47</b>	Block shear	$F_{u;Rd} =$ 10634	<b>0.34</b>
Bearing strength	$F_{b;Rd} =$ 11695	<b>0.35</b>	Shear strength	$F_{v;Rd} =$ 8675	<b>0.42</b>
Combined effect	$F_{v;Rd} =$ 8675	<b>0.47</b>	Bearing strength	$F_{b;Rd} =$ 11825	<b>0.31</b>
		elastisch	Combined effect	$F_{v;Rd} =$ 8675	<b>0.42</b> elastisch

Project: ZW-Oost  
Mast: H\_C

### Angle check

NEN-EN1993-1-1 and EN1993-3-1

Datum: 2021-05-26  
Auteur: TBR  
Versie: 3.0

Member name	Group 110-111	Conclusion
Section	XEA 250x250x24	U.C. (compression) <b>0.81 &lt; 1,0 OK</b>
		U.C. (tension) <b>0.66 &lt; 1,0 OK</b>

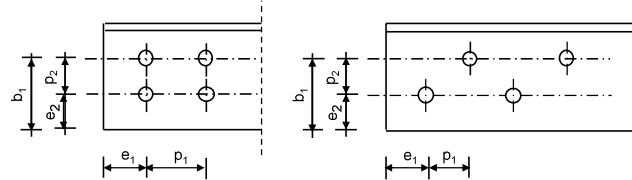
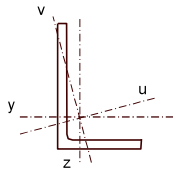

Steel grade **S355**

#### Member loads

Compressive force  $N_{Ed} =$  **5089 kN**  
Tensile force **-4602 kN**

#### Crossing diagonal loads

Applicable: **No**  
Min. tensile force diagonal 2 **1 kN**  
Max. comp. force diagonal 1 **1 kN**  
Position crossing diagonal y-axis **1.00 m**

#### Construction loads

Vertical construction load **1.0 kN**  
Member angle to horizontal **0 °**  
Bending around axis **y-axis**

#### Geometry

System length y-axis  $L_{y,buc} =$  **1.81 m**  
System length z-axis  $L_{z,buc} =$  **1.81 m**  
System length v-axis  $L_{v,buc} =$  **1.81 m**  
System length x-axis  $L_{tk,buc} =$  **1.81 m**  
Member type **Leg**  
Type bracing **Non staggered**

#### End conditions

Begin **Continuous**  
End **Continuous**  
Restraint code TOWER **C4**

#### Bolted connection

Bolt type **M24**  
Bolt class **8.8**  
Number of bolts per leg **6** (24 total)  
Shearplane through **Thread**  
Bolt pattern **Zigzag**  
Bolt pattern (leg-member only) **Staggered**

End distance  $e_1 =$  **55 mm** **Ok**  
Separation distance //  $p_1 =$  **70 mm** **Ok**  
Separation distance |  $p_2 =$  **100 mm** **Ok**  
End distance  $e_2 =$  **50 mm** **Ok**  
Double strap or single strap **Double**  
Tie plate  $b_p =$  **230 mm** **OK**  
 $t_p =$  **15 mm** **OK**  
 $e_2 =$  **40 mm** **OK**

A **23036 mm<sup>2</sup>**  
G **184.3 kg/m**  
Partial safety factor  $\gamma_{f;Q} =$  **1.50**  
Material factors  $\gamma_{M0} =$  **1.00**  
 $\gamma_{M1} =$  **1.00**  
 $\gamma_{M2} =$  **1.25**  
Shear strength bolt  $F_{v;Rd} =$  **135.6 kN**

Slenderness  $\lambda_{max} = L / i :$  **19 -**  
Allowed: **120 OK**

#### Bending due to vertical construction load

$M_{y,Ed} = 1/4 F_{Ed} L_{pr} =$  **0.68 kNm**  
U.C. = **0.00 < 1,00 OK**

#### Results stability

	$\lambda_{eff,rel}$	$\lambda_{eff}$	$\lambda_{eff,mod}$	$\chi_{buc}$	$\eta$	$N_{b,Rd} = \eta \chi A_f \gamma / \gamma_{M1}$
$L_{y,buc} =$ 1.81 m	0.23	1,00 I	0.23	0.99	1	8098 <b>0.63</b>
$L_{z,buc} =$ 1.81 m	0.23	1,00 I	0.23	0.99	1	8098 <b>0.63</b>
$L_{v,buc} =$ 1.81 m	0.25	0,10+0,80 I	0.25	0.98	1	8045 <b>0.63</b>
$L_{tk,buc} =$ 1.81 m	0.64			0.76	1	6250 <b>0.81</b>

#### Bolted connection

Compression	$F_{Rd}$ (kN)	U.C.	Tension	$F_{Rd}$ (kN)	U.C.
Cross section angle $F_{u;Rd} =$	8178	<b>0.62</b>	Net section angle $F_{u;Rd} =$	6987	<b>0.66</b>
Cross section tie plate $F_{u;Rd} =$	8094	<b>0.63</b>	Net section tie plate $F_{u;Rd} =$	6943	<b>0.66</b>
Shear strength $F_{v;Rd} =$	8675	<b>0.59</b>	Block shear $F_{u;Rd} =$	10634	<b>0.43</b>
Bearing strength $F_{b;Rd} =$	11695	<b>0.44</b>	Shear strength $F_{v;Rd} =$	8675	<b>0.53</b>
Combined effect $F_{v;Rd} =$	8675	<b>0.59</b> elastisch	Bearing strength $F_{b;Rd} =$	11825	<b>0.39</b>
			Combined effect $F_{v;Rd} =$	8675	<b>0.53</b> elastisch

Project: ZW-Oost  
Mast: H\_C

**Angle check**

NEN-EN1993-1-1 and EN1993-3-1

Datum: 2021-05-26  
Auteur: TBR  
Versie: 3.0

<b>Member name</b>	<b>Group 112.1-113.1-114.1</b>	<b>Conclusion</b>
<b>Section</b>	<b>XEA 250x250x24</b>	U.C. (compression) <b>0.85 &lt; 1,0 OK</b>
		U.C. (tension) <b>0.62 &lt; 1,0 OK</b>

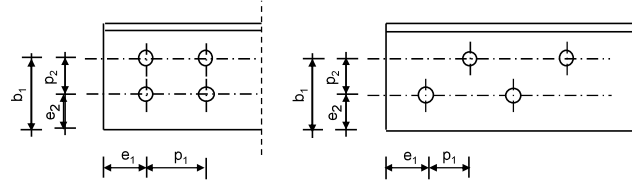
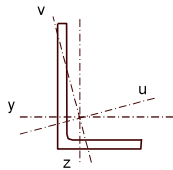

Steel grade **S355**

**Member loads**

Compressive force  $N_{Ed} =$  **5283 kN**  
Tensile force **-4323 kN**

**Crossing diagonal loads**

Applicable: **No**  
Min. tensile force diagonal 2 **1 kN**  
Max. comp. force diagonal 1 **1 kN**  
Position crossing diagonal y-axis **1.00 m**

**Construction loads**

Vertical construction load **1.0 kN**  
Member angle to horizontal **0 °**  
Bending around axis **y-axis**

**Geometry**

System length y-axis  $L_{y,buc} =$  **1.96 m**  
System length z-axis  $L_{z,buc} =$  **1.96 m**  
System length v-axis  $L_{v,buc} =$  **1.96 m**  
System length x-axis  $L_{tk,buc} =$  **1.96 m**  
Member type **Leg**  
Type bracing **Non staggered**

**End conditions**

Begin **Continuous**  
End **Continuous**  
Restraint code TOWER **C4**

**Bolted connection**

Bolt type **M24**  
Bolt class **8.8**  
Number of bolts per leg **6** (24 total)  
Shearplane through **Thread**  
Bolt pattern **Zigzag**  
Bolt pattern (leg-member only) **Staggered**

End distance  $e_1 =$  **55 mm** **Ok**  
Separation distance //  $p_1 =$  **70 mm** **Ok**  
Separation distance |  $p_2 =$  **100 mm** **Ok**  
End distance  $e_2 =$  **50 mm** **Ok**  
Double strap or single strap **Double**  
Tie plate  $b_p =$  **230 mm** **OK**  
 $t_p =$  **15 mm** **OK**  
 $e_2 =$  **40 mm** **OK**

A **23036 mm<sup>2</sup>**  
G **184.3 kg/m**  
Partial safety factor  $\gamma_{f;Q} =$  **1.50**  
Material factors  $\gamma_{M0} =$  **1.00**  
 $\gamma_{M1} =$  **1.00**  
 $\gamma_{M2} =$  **1.25**  
Shear strength bolt  $F_{v;b;Rd} =$  **135.6 kN**

**Slenderness**  $\lambda_{max} = L / i :$  **20 -**  
Allowed: **120** **OK**

**Bending due to vertical construction load**

$M_{y,Ed} = 1/4 F_{Ed} L_{pr} =$  **0.74 kNm**  
U.C. = **0.00 < 1,00 OK**

**Results stability**

	$\lambda_{eff,rel}$	$\lambda_{eff}$	$\lambda_{eff,mod}$	$\chi_{buc}$	$\eta$	$N_{b,Rd} = \eta \chi A_f \gamma / \gamma_{M1}$
$L_{y,buc} =$ 1.96 m	0.25	1,00 I	0.25	0.98	1	8043 <b>0.66</b>
$L_{z,buc} =$ 1.96 m	0.25	1,00 I	0.25	0.98	1	8043 <b>0.66</b>
$L_{v,buc} =$ 1.96 m	0.27	0,10+0,80 I	0.27	0.98	1	7985 <b>0.66</b>
$L_{tk,buc} =$ 1.96 m	0.64			0.76	1	6216 <b>0.85</b>

**Bolted connection**

Compression	$F_{Rd}$ (kN)	U.C.	Tension	$F_{Rd}$ (kN)	U.C.
Cross section angle $F_{u;Rd} =$	8178	<b>0.65</b>	Net section angle $F_{u;Rd} =$	6987	<b>0.62</b>
Cross section tie plate $F_{u;Rd} =$	8094	<b>0.65</b>	Net section tie plate $F_{u;Rd} =$	6943	<b>0.62</b>
Shear strength $F_{v;Rd} =$	8675	<b>0.61</b>	Block shear $F_{u;Rd} =$	10634	<b>0.41</b>
Bearing strength $F_{b;Rd} =$	11695	<b>0.45</b>	Shear strength $F_{v;Rd} =$	8675	<b>0.50</b>
Combined effect $F_{v;Rd} =$	8675	<b>0.61</b> elastisch	Bearing strength $F_{b;Rd} =$	11825	<b>0.37</b>
			Combined effect $F_{v;Rd} =$	8675	<b>0.50</b> elastisch

Project: ZW-Oost  
Mast: H\_C

### Angle check

NEN-EN1993-1-1 and EN1993-3-1

Datum: 2021-05-10  
Auteur: TBR  
Versie: 3.0

Member name	Group 112.2-113.2-114.2	Conclusion
Section	XEA 250x250x24	U.C. (compression) <b>0.83 &lt; 1,0 OK</b>
		U.C. (tension) <b>0.66 &lt; 1,0 OK</b>

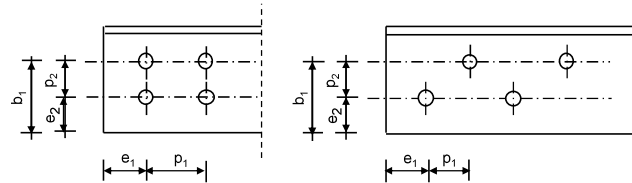
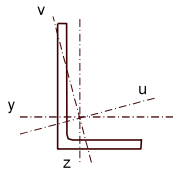

Steel grade **S355**

#### Member loads

Compressive force  $N_{Ed} =$  **5130 kN**  
Tensile force **-4595 kN**

#### Crossing diagonal loads

Applicable: **No**  
Min. tensile force diagonal 2 **1 kN**  
Max. comp. force diagonal 1 **1 kN**  
Position crossing diagonal y-axis **1.00 m**

#### Construction loads

Vertical construction load **1.0 kN**  
Member angle to horizontal **0 °**  
Bending around axis **y-axis**

#### Geometry

System length y-axis  $L_{y,buc} =$  **2.08 m**  
System length z-axis  $L_{z,buc} =$  **2.08 m**  
System length v-axis  $L_{v,buc} =$  **2.08 m**  
System length x-axis  $L_{tk,buc} =$  **2.08 m**  
Member type **Leg**  
Type bracing **Non staggered**

#### End conditions

Begin **Continuous**  
End **Continuous**  
Restraint code TOWER **C4**

#### Bolted connection

Bolt type **M24**  
Bolt class **8.8**  
Number of bolts per leg **6** (24 total)  
Shearplane through **Thread**  
Boltpattern **Zigzag**  
Boltpattern (leg-member only) **Staggered**

End distance  $e_1 =$  **55 mm** **Ok**  
Separation distance //  $p_1 =$  **70 mm** **Ok**  
Separation distance |  $p_2 =$  **100 mm** **Ok**  
End distance  $e_2 =$  **50 mm** **Ok**  
Double strap or single strap **Double**  
Tie plate  $b_p =$  **230 mm** **OK**  
 $t_p =$  **15 mm** **OK**  
 $e_2 =$  **40 mm** **OK**

A **23036 mm<sup>2</sup>**  
G **184.3 kg/m**  
Partial safety factor  $\gamma_{f;Q} =$  **1.50**  
Material factors  $\gamma_{M0} =$  **1.00**  
 $\gamma_{M1} =$  **1.00**  
 $\gamma_{M2} =$  **1.25**  
Shear strength bolt  $F_{v;b;Rd} =$  **135.6 kN**

Slenderness  $\lambda_{max} = L / i :$  **22 -**  
Allowed: **120** **OK**

#### Bending due to vertical construction load

$M_{y,Ed} = 1/4 F_{Ed} L_{pr} =$  **0.78 kNm**  
U.C. = **0.00 < 1,00 OK**

#### Results stability

	$\lambda_{eff,rel}$	$\lambda_{eff}$	$\lambda_{eff,mod}$	$\chi_{buc}$	$\eta$	$N_{b,Rd} = \eta \chi A_f \gamma / \gamma_{M1}$
$L_{y,buc} =$ 2.08 m	0.26	1,00 I	0.26	0.98	1	7998 <b>0.64</b>
$L_{z,buc} =$ 2.08 m	0.26	1,00 I	0.26	0.98	1	7998 <b>0.64</b>
$L_{v,buc} =$ 2.08 m	0.28	0,10+0,80 I	0.28	0.97	1	7937 <b>0.65</b>
$L_{tk,buc} =$ 2.08 m	0.65			0.76	1	6194 <b>0.83</b>

#### Bolted connection

Compression	$F_{Rd}$ (kN)	U.C.	Tension	$F_{Rd}$ (kN)	U.C.
Cross section angle	$F_{u;Rd} =$ 8178	<b>0.63</b>	Net section angle	$F_{u;Rd} =$ 6987	<b>0.66</b>
Cross section tie plate	$F_{u;Rd} =$ 8094	<b>0.63</b>	Net section tie plate	$F_{u;Rd} =$ 6943	<b>0.66</b>
Shear strength	$F_{v;Rd} =$ 8675	<b>0.59</b>	Block shear	$F_{u;Rd} =$ 10634	<b>0.43</b>
Bearing strength	$F_{b;Rd} =$ 11695	<b>0.44</b>	Shear strength	$F_{v;Rd} =$ 8675	<b>0.53</b>
Combined effect	$F_{v;Rd} =$ 8675	<b>0.59</b> elastisch	Bearing strength	$F_{b;Rd} =$ 11825	<b>0.39</b>
			Combined effect	$F_{v;Rd} =$ 8675	<b>0.53</b> elastisch

Project: ZW-Oost  
Mast: H\_C



**Angle check**

NEN-EN1993-1-1 and EN1993-3-1

Datum: 2021-05-26  
Auteur: TBR  
Versie: 3.0

<b>Member name</b>	<b>Group 112.3-113.3-114.3</b>	<b>Conclusion</b>
<b>Section</b>	<b>XEA 250x250x24</b>	U.C. (compression) <b>0.91 &lt; 1,0 OK</b>
		U.C. (tension) <b>0.72 &lt; 1,0 OK</b>

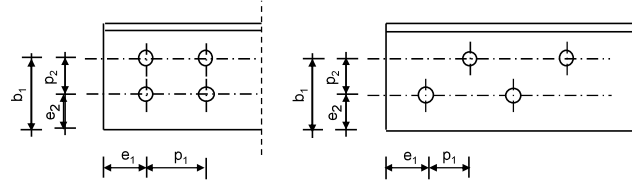
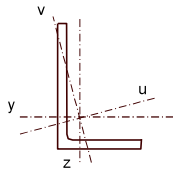

Steel grade **S355**

**Member loads**  
Compressive force  $N_{Ed} =$  **5596 kN**  
Tensile force **-5021 kN**

**Crossing diagonal loads**  
Applicable: **No**  
Min. tensile force diagonal 2 **1 kN**  
Max. comp. force diagonal 1 **1 kN**  
Position crossing diagonal y-axis **1.00 m**

**Construction loads**  
Vertical construction load **1.0 kN**  
Member angle to horizontal **0 °**  
Bending around axis **y-axis**

**Geometry**  
System length y-axis  $L_{y,buc} =$  **2.38 m**  
System length z-axis  $L_{z,buc} =$  **2.38 m**  
System length v-axis  $L_{v,buc} =$  **2.38 m**  
System length x-axis  $L_{tk,buc} =$  **2.38 m**  
Member type **Leg**  
Type bracing **Non staggered**

**End conditions**  
Begin **Continuous**  
End **Continuous**  
Restraint code TOWER **C4**

**Bolted connection**  
Bolt type **M24**  
Bolt class **8.8**  
Number of bolts per leg **6** (24 total)  
Shearplane through **Thread**  
Boltpattern **Zigzag**  
Boltpattern (leg-member only) **Staggered**

End distance  $e_1 =$  **55 mm** **Ok**  
Separation distance //  $p_1 =$  **70 mm** **Ok**  
Separation distance |  $p_2 =$  **100 mm** **Ok**  
End distance  $e_2 =$  **50 mm** **Ok**  
Double strap or single strap **Double**  
Tie plate  $b_p =$  **230 mm** **OK**  
 $t_p =$  **15 mm** **OK**  
 $e_2 =$  **40 mm** **OK**

A **23036 mm<sup>2</sup>**  
G **184.3 kg/m**  
Partial safety factor  $\gamma_{F;Q} =$  **1.50**  
Material factors  $\gamma_{M0} =$  **1.00**  
 $\gamma_{M1} =$  **1.00**  
 $\gamma_{M2} =$  **1.25**  
Shear strength bolt  $F_{v;b;Rd} =$  **135.6 kN**

**Slenderness**  $\lambda_{max} = L / i :$  **25 -**  
Allowed: **120 OK**

**Bending due to vertical construction load**  
 $M_{y,Ed} = 1/4 F_{Ed} L_{pr} =$  **0.89 kNm**  
U.C. = **0.00 < 1,00 OK**

**Results stability**

	$\lambda_{eff,rel}$	$\lambda_{eff}$	$\lambda_{eff,mod}$	$\chi_{buc}$	$\eta$	$N_{b,Rd} = \eta \chi A_f \gamma / \gamma_{M1}$
$L_{y,buc} =$ 2.38 m	0.30	1,00 I	0.30	0.96	1	7887 <b>0.71</b>
$L_{z,buc} =$ 2.38 m	0.30	1,00 I	0.30	0.96	1	7887 <b>0.71</b>
$L_{v,buc} =$ 2.38 m	0.32	0,10+0,80 I	0.32	0.96	1	7814 <b>0.72</b>
$L_{tk,buc} =$ 2.38 m	0.66			0.75	1	6150 <b>0.91</b>

**Bolted connection**

	$F_{Rd}$ (kN)	U.C.		$F_{Rd}$ (kN)	U.C.
Compression			Tension		
Cross section angle $F_{u;Rd} =$	8178	<b>0.68</b>	Net section angle $F_{u;Rd} =$	6987	<b>0.72</b>
Cross section tie plate $F_{u;Rd} =$	8094	<b>0.69</b>	Net section tie plate $F_{u;Rd} =$	6943	<b>0.72</b>
Shear strength $F_{v;Rd} =$	8675	<b>0.65</b>	Block shear $F_{u;Rd} =$	10634	<b>0.47</b>
Bearing strength $F_{b;Rd} =$	11695	<b>0.48</b>	Shear strength $F_{v;Rd} =$	8675	<b>0.58</b>
Combined effect $F_{v;Rd} =$	8675	<b>0.65</b> elastisch	Bearing strength $F_{b;Rd} =$	11825	<b>0.42</b>
			Combined effect $F_{v;Rd} =$	8675	<b>0.58</b> elastisch

## APPENDIX C

### Knikverkorters

---

Niet in PLS-TOWER gemodelleerde elementen in de constructie worden aanvullend getoetst. Hieronder vallen de knikverkorters van de randstijl en profielen onderdeel van stabiliteitsverbanden. De staven worden getoetst op:

- voldoende trek- of druksterkte als steunegend profiel voor randstijl, 1% van de knikcapaciteit van de randstijl;
- slankheid;
- klimbelasting

Voor de beloopbaarheid zijn staven in de traverse aanwezig. Deze zijn niet constructief (voorzien van slobgaten) en worden enkel getoetst op de klimbelasting van 1,0 kN. Zie hoofdstuk 4.2.5 en 5.7.2. van het uitgangspuntenrapport.

De knikverkorters van het bovenstuk zijn voor alle masttypen in de groep van combi-hoekmasten gelijk. Om deze reden worden alléén voor masttype HB+0/c de knikverkorters van het bovenstuk en het onderstuk getoetst. Voor de overige masttypen worden alleen de knikverkorters van het onderstuk getoetst.

Profielen uit horizontaalverbanden van het onderstuk zijn in PLS-TOWER aanwezig maar worden in deze Appendix aanvullend getoetst op buiging. Profielafmeting en boutverbinding uit PLS-TOWER is leidend.



# Overzicht knikverkorters – HB+0/c

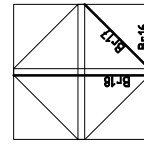
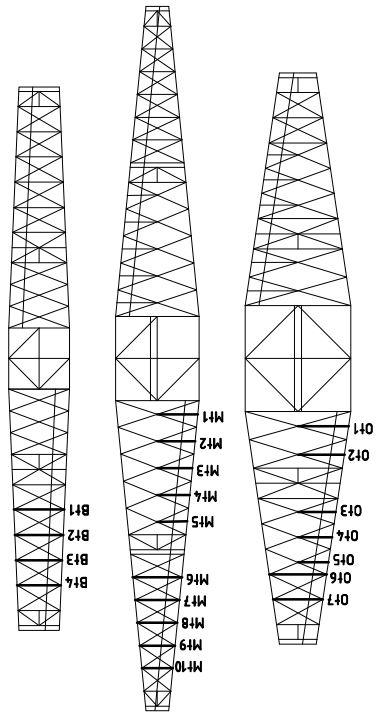

Tussenschot +15,9m

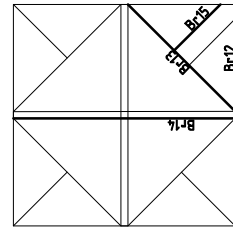

Tussenschot +6,04m

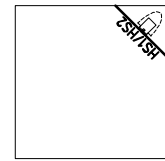

Standaard frame

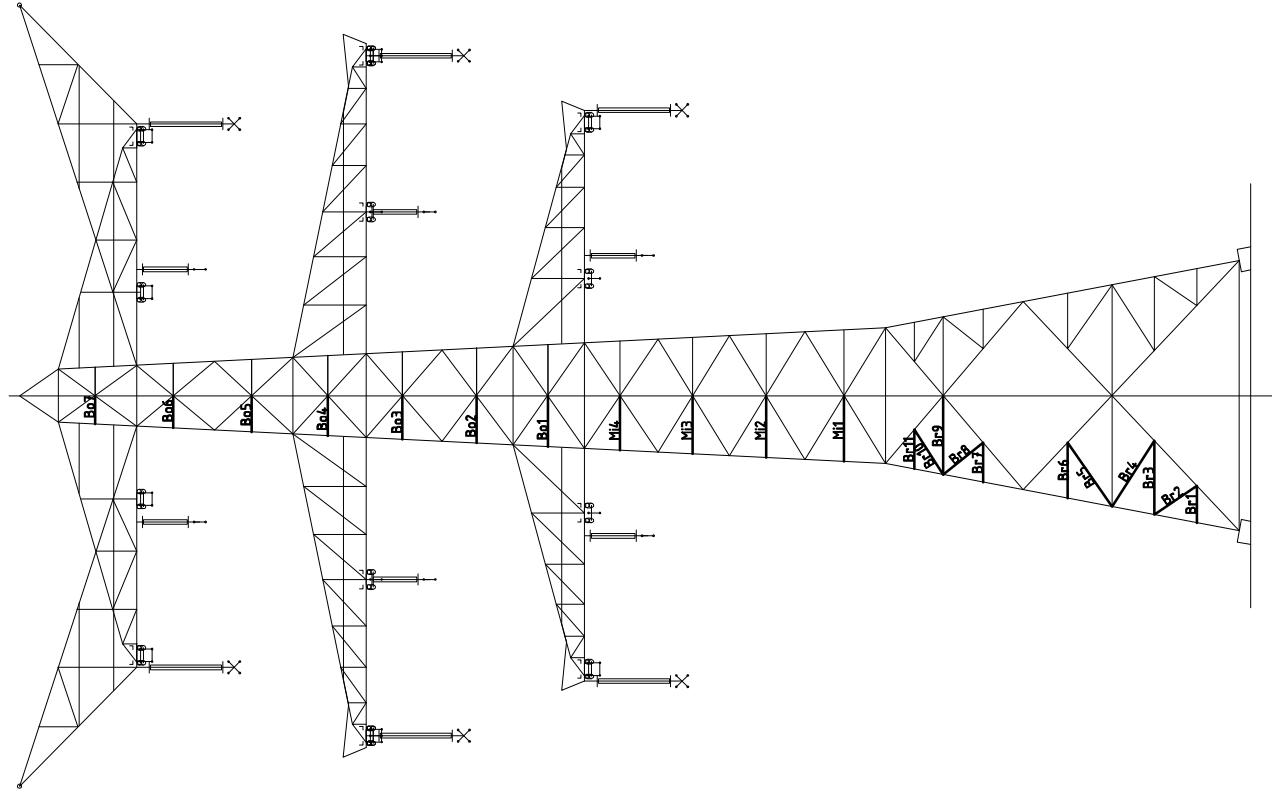



**Redundant members**

RLI-TLB  
HB+0/c

Date: 2021-07-09  
Author: MRE  
Version: 1.9

Posnr.	Section	Schematization	Profile	Steel Quality	Bolt Quality	Length (m)	Angle (°)	Slenderness	Normal Force (kN)	Moment (kNm)	Buckling Cap. (kN)	Shear Cap. Bolt (kN)	Bearing Cap. (kN)	Net Section Cap. (kN)	Moment Cap. (kNm)	Highest U.C.	Max. usage	Notes
B1	Broekstuk	Enkele staaf	L70x6	S355J0	M20	8.8	1.62	0	118	62.0	0.61	85.4	94.1	71.3	112.9	1.99	0.87	Bearing
B2	Broekstuk	Enkele staaf	L80x6	S355J0	M20	8.8	2.24	55	142	62.0	0.00	77.3	94.1	71.3	136.4	2.68	0.87	Bearing
B3	Broekstuk	Enkele staaf	L90x8	S355J0	M20	8.8	3.23	0	183	62.0	1.21	80.6	94.1	95.0	213.2	4.34	0.77	Buckling
B4	Broekstuk	Enkele staaf	L90x8	S355J0	M20	8.8	3.41	33	194	62.0	0.00	74.2	94.1	95.0	213.2	4.34	0.84	Buckling
B5	Broekstuk	Enkele staaf	L90x8	S355J0	M20	8.8	3.40	33	193	62.0	0.00	74.5	94.1	95.0	213.2	4.34	0.83	Buckling
B6	Broekstuk	Enkele staaf	L80x6	S355J0	M20	8.8	2.50	0	159	62.0	0.94	66.6	94.1	71.3	136.4	2.68	0.93	Buckling
B7	Broekstuk	Enkele staaf	L70x6	S355J0	M20	8.8	1.72	0	125	62.0	0.64	79.3	94.1	71.3	112.9	1.99	0.87	Bearing
B8	Broekstuk	Enkele staaf	L80x6	S355J0	M20	8.8	2.23	51	141	62.0	0.00	78.0	94.1	71.3	136.4	2.68	0.87	Bearing
B9	Broekstuk	Enkele staaf	L90x8	S355J0	M20	8.8	3.43	0	195	62.0	1.29	73.5	94.1	95.0	213.2	4.34	0.84	Buckling
B10	Broekstuk	Enkele staaf	L80x6	S355J0	M20	8.8	2.32	33	148	62.0	0.44	71.6	94.1	71.3	136.4	2.68	0.87	Bearing
B11	Broekstuk	Enkele staaf	L70x6	S355J0	M20	8.8	1.17	0	86	62.0	0.00	119.0	94.1	71.3	112.9	1.99	0.87	Bearing
B12	Tussenschot +6,04m	Enkele staaf	L100x8	S355J0	M16	8.8	4.83	0	245	0.0	1.81	57.4	60.3	69.7	257.2	5.49	0.34	Bending
B13	Tussenschot +6,04m	Kruisende staaf halverwege	L100x8	S355J0	M16	8.8	6.83	0	222	0.0	2.56	56.8	60.3	69.7	257.2	7.19	0.25	Bending
B14	Tussenschot +6,04m	Enkele staaf	L70x6	S355J0	M16	8.8	3.41	0	245	0.0	1.81	57.4	60.3	69.7	257.2	7.19	0.25	Bending
B15	Tussenschot +6,04m	Enkele staaf	L130x12	S355J0	M16	8.8	2.94	0	249	0.7	1.28	29.4	60.3	52.3	122.3	1.99	0.67	Bending
B16	Tussenschot +15,9m	Enkele staaf	L90x8	S355J0	M16	8.8	4.17	0	74	0.0	1.10	380.6	60.3	104.5	620.9	17.91	0.06	Bending
B17	Tussenschot +15,9m	Enkele staaf	L90x8	S355J0	M16	8.8	5.91	0	237	0.0	1.56	54.4	60.3	69.7	225.8	4.34	0.37	Bending
B18	Tussenschot +15,9m	Kruisende staaf halverwege	L80x8	S355J0	M20	8.8	2.87	0	168	0.0	1.11	91.6	60.3	69.7	225.8	5.70	0.19	Bending
M1	Middenstuk1	Enkele staaf	L80x8	S355J0	M20	8.8	2.70	0	184	62.3	1.07	71.0	94.1	95.0	181.9	3.33	0.88	Buckling
M2	Middenstuk1	Enkele staaf	L80x6	S355J0	M20	8.8	2.53	0	161	52.2	0.95	65.3	94.1	95.0	181.9	3.33	0.80	Buckling
M3	Middenstuk2	Enkele staaf	L80x6	S355J0	M20	8.8	2.38	0	151	52.2	0.89	71.4	94.1	71.3	136.4	2.68	0.80	Buckling
M4	Middenstuk2	Enkele staaf	L70x6	S355J0	M16	8.8	2.22	0	162	38.0	0.78	62.0	60.3	52.3	122.3	1.99	0.73	Bearing
B01	Bovenstuk1	Enkele staaf	L70x6	S355J0	M16	8.8	2.07	0	151	38.0	0.78	62.0	60.3	52.3	122.3	1.99	0.73	Bearing
B02	Bovenstuk1	Enkele staaf	L60x6	S355J0	M16	8.8	1.90	0	163	38.0	0.71	47.5	60.3	52.3	98.8	1.4	0.80	Buckling
B03	Bovenstuk2	Enkele staaf	L50x5	S355J0	M16	8.8	1.74	0	179	13.6	0.65	28.8	60.3	41.3	43.1	0.8	0.83	Bending
B04	Bovenstuk2	Enkele staaf	L50x5	S355J0	M16	8.8	1.58	0	162	13.6	0.59	33.3	60.3	41.3	43.1	0.8	0.75	Bending
B05	Bovenstuk2	Enkele staaf	L50x5	S355J0	M16	8.8	1.41	0	144	13.6	0.53	39.0	60.3	41.3	43.1	0.8	0.67	Bending
B06	Bovenstuk2	Enkele staaf	L50x5	S355J0	M16	8.8	1.24	0	127	7.4	0.46	46.0	60.3	41.3	43.1	0.8	0.59	Bending
B07	Bovenstuk2	Enkele staaf	L60x6	S355J0	M16	8.8	2.20	0	188	0.0	0.83	38.5	60.3	52.3	98.8	1.4	0.61	Bending
O1	Ondertaverse	Enkele staaf	L50x5	S355J0	M16	8.8	2.02	0	208	0.0	0.76	23.1	60.3	41.3	43.1	0.8	0.97	Bending
O2	Ondertaverse	Enkele staaf	L50x5	S355J0	M16	8.8	1.65	0	170	0.0	0.62	31.2	60.3	41.3	43.1	0.8	0.79	Bending
O3	Ondertaverse	Enkele staaf	L50x5	S355J0	M16	8.8	1.48	0	152	0.0	0.56	36.3	60.3	41.3	43.1	0.8	0.71	Bending
O4	Ondertaverse	Enkele staaf	L50x5	S355J0	M16	8.8	1.32	0	136	0.0	0.50	42.3	60.3	41.3	43.1	0.8	0.63	Bending
O5	Ondertaverse	Enkele staaf	L60x6	S355J0	M16	8.8	2.50	0	214	0.0	0.94	31.7	60.3	52.3	98.8	1.4	0.69	Bending
O6	Ondertaverse	Enkele staaf	L60x6	S355J0	M16	8.8	2.18	0	187	0.0	0.82	28.2	60.3	52.3	98.8	1.4	0.60	Bending
O7	Ondertaverse	Enkele staaf	L50x5	S355J0	M16	8.8	1.77	0	182	0.0	0.66	39.0	60.3	41.3	43.1	0.8	0.85	Bending
M1	Middentraverse	Enkele staaf	L50x5	S355J0	M16	8.8	1.65	0	170	0.0	0.62	31.2	60.3	41.3	43.1	0.8	0.79	Bending
M2	Middentraverse	Enkele staaf	L50x5	S355J0	M16	8.8	1.54	0	158	0.0	0.58	34.4	60.3	41.3	43.1	0.8	0.74	Bending
M3	Middentraverse	Enkele staaf	L50x5	S355J0	M16	8.8	1.42	0	146	0.0	0.53	38.4	60.3	41.3	43.1	0.8	0.68	Bending
M4	Middentraverse	Enkele staaf	L50x5	S355J0	M16	8.8	1.31	0	135	0.0	0.49	42.7	60.3	41.3	43.1	0.8	0.63	Bending
M5	Middentraverse	Enkele staaf	L60x6	S355J0	M16	8.8	2.14	0	183	0.0	0.80	40.1	60.3	52.3	98.8	1.4	0.59	Bending
M6	Middentraverse	Enkele staaf	L50x5	S355J0	M16	8.8	1.95	0	200	0.0	0.73	24.4	60.3	41.3	43.1	0.8	0.93	Bending
M7	Middentraverse	Enkele staaf	L50x5	S355J0	M16	8.8	1.75	0	180	0.0	0.66	28.6	60.3	41.3	43.1	0.8	0.84	Bending
M8	Middentraverse	Enkele staaf	L50x5	S355J0	M16	8.8	1.56	0	160	0.0	0.59	40.7	60.3	41.3	43.1	0.8	0.75	Bending
M9	Middentraverse	Enkele staaf	L50x5	S355J0	M16	8.8	1.36	0	140	0.0	0.51	47.0	60.3	41.3	43.1	0.8	0.65	Bending
M10	Middentraverse	Enkele staaf	L60x6	S355J0	M16	8.8	2.21	0	189	0.0	0.83	38.3	60.3	52.3	98.8	1.4	0.61	Bending
B11	Boventraverse	Enkele staaf	L60x6	S355J0	M16	8.8	2.21	0	189	0.0	0.83	38.3	60.3	52.3	98.8	1.4	0.61	Bending



**Redundant members**

RLL-TLB  
HB+0/c

Date: 2021-07-09  
Author: MRE  
Version: 1.9

Posnr.	Section	Schematization	Profile	Steel Quality	Bolt Quality	Length (m)	Angle (°)	Slenderness	Normal Force (kN)	Moment (kNm)	Buckling Cap. (kN)	Shear Cap. Bolt (kN)	Bearing Cap. (kN)	Net Section Cap. (kN)	Moment Cap. (kNm)	Highest U.C.	Max. usage	Notes
B2	Boventraverse	Enkele staaf	L60x6	S355/0	M16	8.8	2.11	0	181	0.0	41.0	60.3	52.3	98.8	1.4	0.58	Bending	
B3	Boventraverse	Enkele staaf	L50x5	S355/0	M16	8.8	2.02	0	208	0.0	23.1	60.3	41.3	43.1	0.8	0.97	Bending	
B4	Boventraverse	Enkele staaf	L50x5	S355/0	M16	8.8	1.92	0	197	0.0	24.9	60.3	41.3	43.1	0.8	0.97	Bending	
H51	High Step	Enkele staaf	L80x6	S355/0	M16	8.8	3.25	0	207	0.0	45.2	60.3	52.3	145.8	2.7	0.95	Bending	
H52	High Step	Enkele staaf	L70x7	S355/0	M16	8.8	2.80	0	205	0.0	46.0	60.3	61.0	142.7	2.2	0.97	Bending	

# Overzicht knikverkorters – HB+6/c

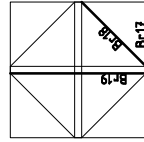
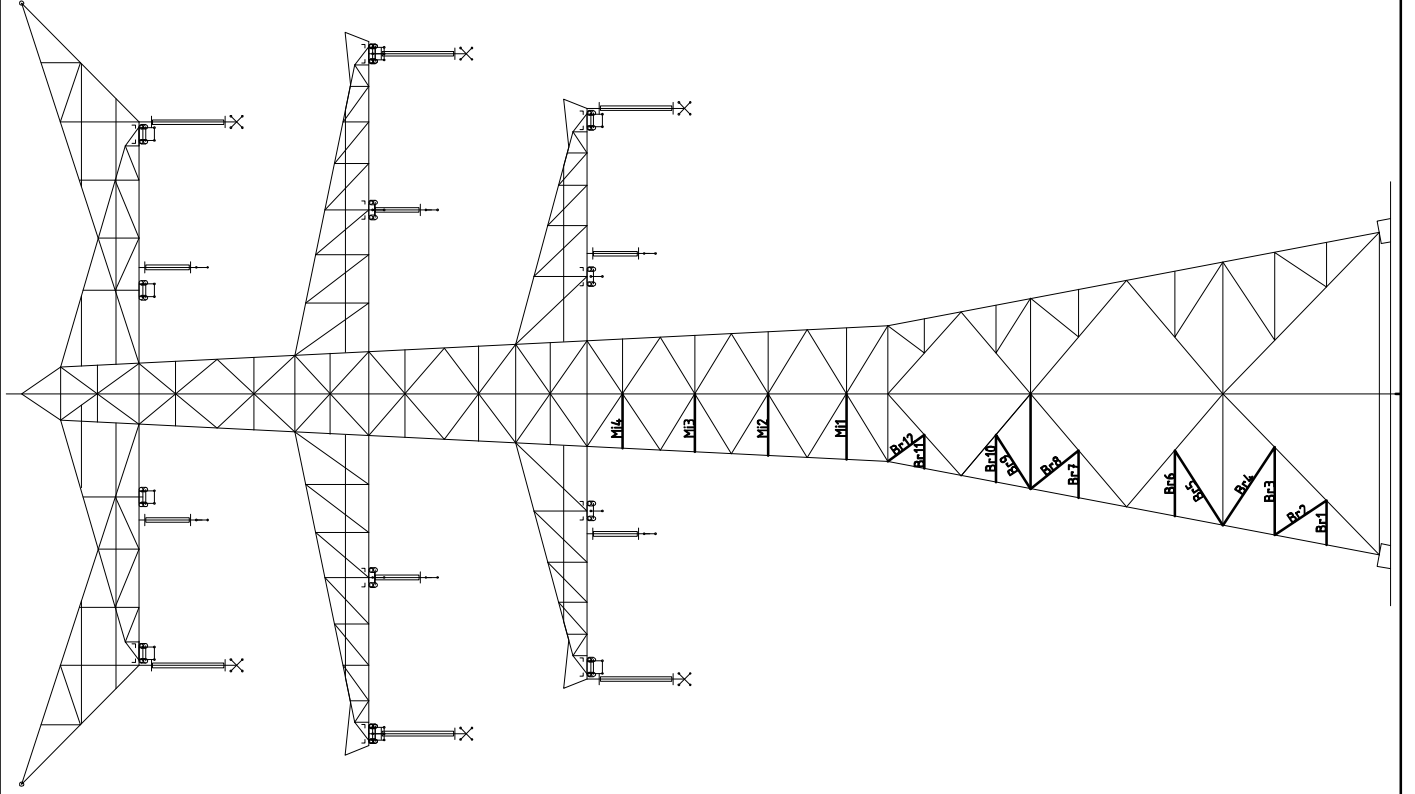

Tussenschot +21,9m

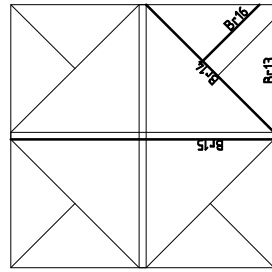

Tussenschot +7,3m



**Redundant members**

RLL-TLB  
HB+6/c

Date: 2021-07-09  
Author: MRE  
Version: 1.9

Posnr.	Section	Schematization	Profile	Steel Quality	Bolt Quality	Length (m)	Angle (°)	Slenderness	Normal Force (kN)	Moment (kNm)	Buckling Cap. (kN)	Shear Cap. Bolt (kN)	Bearing Cap. (kN)	Net Section Cap. (kN)	Moment Cap. (kNm)	Highest U.C.	Max. usage	Notes
Br1	Broekstuk	Enkele staaf	L70x6	S355J0	M20	8.8	1.94	0	141	61.5	0.73	67.8	94.1	71.3	112.9	1.99	0.91	Buckling
Br2	Broekstuk	Enkele staaf	L80x8	S355J0	M20	8.8	2.71	56	174	61.5	0.00	77.0	94.1	95.0	181.9	3.33	0.80	Buckling
Br3	Broekstuk	Enkele staaf	L90x9	S355J0	M20	8.8	3.83	0	218	1.44	1.44	69.0	94.1	106.9	239.9	4.73	0.89	Buckling
Br4	Broekstuk	Enkele staaf	L100x10	S355J0	M20	8.8	4.08	30	209	61.5	1.33	91.4	94.1	118.8	305.8	6.49	0.67	Buckling
Br5	Broekstuk	Enkele staaf	L90x9	S355J0	M20	8.8	3.88	30	221	61.5	1.26	67.6	94.1	106.9	239.9	4.73	0.91	Buckling
Br6	Broekstuk	Enkele staaf	L80x8	S355J0	M20	8.8	2.86	0	183	61.5	1.07	71.2	94.1	95.0	181.9	3.33	0.86	Buckling
Br7	Broekstuk	Enkele staaf	L80x6	S355J0	M20	8.8	2.07	0	132	61.5	0.78	85.6	94.1	71.3	136.4	2.68	0.86	Bearing
Br8	Broekstuk	Enkele staaf	L80x8	S355J0	M20	8.8	2.68	51	172	61.5	0.00	78.3	94.1	95.0	181.9	3.33	0.79	Buckling
Br9	Broekstuk	Enkele staaf	L80x8	S355J0	M20	8.8	2.80	30	180	61.5	0.91	73.4	94.1	83.2	131.7	2.23	0.84	Buckling
Br10	Broekstuk	Enkele staaf	L70x7	S355J0	M20	8.8	2.07	0	152	61.5	0.78	71.3	94.1	95.0	181.9	3.33	0.86	Buckling
Br11	Broekstuk	Enkele staaf	L60x6	S355J0	M20	8.8	1.48	0	127	61.5	0.56	66.4	94.1	64.7	65.9	1.40	0.94	Bearing
Br12	Broekstuk	Enkele staaf	L70x6	S355J0	M20	8.8	1.98	54	144	61.5	0.00	66.0	94.1	71.3	112.9	1.99	0.93	Buckling
Br13	Tussenschot +6,04m	Enkele staaf	L120x10	S355J0	M16	8.8	4.83	0	203	0.0	1.81	115.2	60.3	87.1	395.8	9.77	0.19	Bending
Br14	Tussenschot +6,04m	Kniksteun op 0,5L	L110x10	S355J0	M16	8.8	6.83	0	203	0.0	2.56	87.7	60.3	87.1	360.6	10.69	0.24	Bending
Br15	Tussenschot +6,04m	Kruisende staaf halverwege	L120x10	S355J0	M16	8.8	9.65	0	203	0.0	1.81	115.3	60.3	87.1	395.8	12.83	0.14	Bending
Br16	Tussenschot +6,04m	Enkele staaf	L70x6	S355J0	M16	8.8	3.41	0	299	0.0	1.28	29.4	60.3	52.3	122.3	1.99	0.67	Bending
Br17	Tussenschot +15,9m	Kniksteun op 0,5L	L130x12	S355J0	M16	8.8	2.94	0	74	0.0	1.10	380.6	60.3	104.5	620.9	17.91	0.06	Bending
Br18	Tussenschot +15,9m	Enkele staaf	L90x8	S355J0	M16	8.8	4.17	0	237	0.0	1.56	54.4	60.3	69.7	225.8	4.34	0.37	Bending
Br19	Tussenschot +15,9m	Kruisende staaf halverwege	L90x8	S355J0	M16	8.8	5.91	0	168	0.0	1.11	91.6	60.3	69.7	225.8	5.70	0.19	Bending
M1	Middenstuk1	Enkele staaf	L80x8	S355J0	M20	8.8	2.87	0	184	62.3	1.07	71.0	94.1	95.0	181.9	3.33	0.88	Buckling
M2	Middenstuk1	Enkele staaf	L80x8	S355J0	M20	8.8	2.70	0	173	62.3	1.01	77.6	94.1	95.0	181.9	3.33	0.80	Buckling
M3	Middenstuk2	Enkele staaf	L80x6	S355J0	M20	8.8	2.53	0	161	52.2	0.95	65.3	94.1	71.3	136.4	2.68	0.80	Buckling
M4	Middenstuk2	Enkele staaf	L80x6	S355J0	M20	8.8	2.38	0	151	52.2	0.89	71.4	94.1	71.3	136.4	2.68	0.73	Bearing



## **APPENDIX D**

### **Blokdeuvels**

---



Het uitgangspunt voor de berekening van de ingestorte rand met blokdeuvels zijn de belastingen op de fundatie uit de uitvoer van het geleiderbelastingprogramma van DNV. De belastingen in de richting van de randstijl zijn van toepassing. In de tabellen is dit opgenomen in de laatste kolom  $R_{z,lok}$ . De controles zijn uitgevoerd met een spreadsheet. Vanwege de helling van de drukdiagonaal wordt per krachtrichting bepaald hoeveel deuvels effectief zijn, hierdoor is het aantal ingevoerde deuvels in de berekening kleiner dan het aantal deuvels op de principetekening.

Er wordt voor gekozen om de blokdeuvels universeel uit te werken op basis van het profiel van de randstijl, dit betreft een XEA250x250x24-profiel en heeft betrekking op de volgende masttypen:

- Masttype HA+0/c, HA+0/ci, HA+3/c, HA+3/ca en HA+6/c;
- Masttype HB+0/c en HB+6/c;
- Masttype HC+0/c;
- Masttype WA+0/c en WA+6/c;
- Masttype WB+0/c;
- Masttype EA-3/co.

De blokdeuvels worden getoetst op de maatgevende belasting van bovenstaande masttypen. De belasting is opgenomen in Appendix A van het betreffende masttype, masttype HC+0/c is maatgevend. De optredende belastingen van masttype HC+0/c zijn 5503kN (druk) en -4739kN (trek), deze worden ruim naar boven afgerond op **5600kN** (druk) en **-4800kN** (trek). Met deze belastingen worden alle masttypen geborgd en hebben eventuele kleine aanpassingen geen invloed op deze uitwerking.

# Principe blokdeuvels - combi-hoek-, combi-wissel en combi-eindmasten

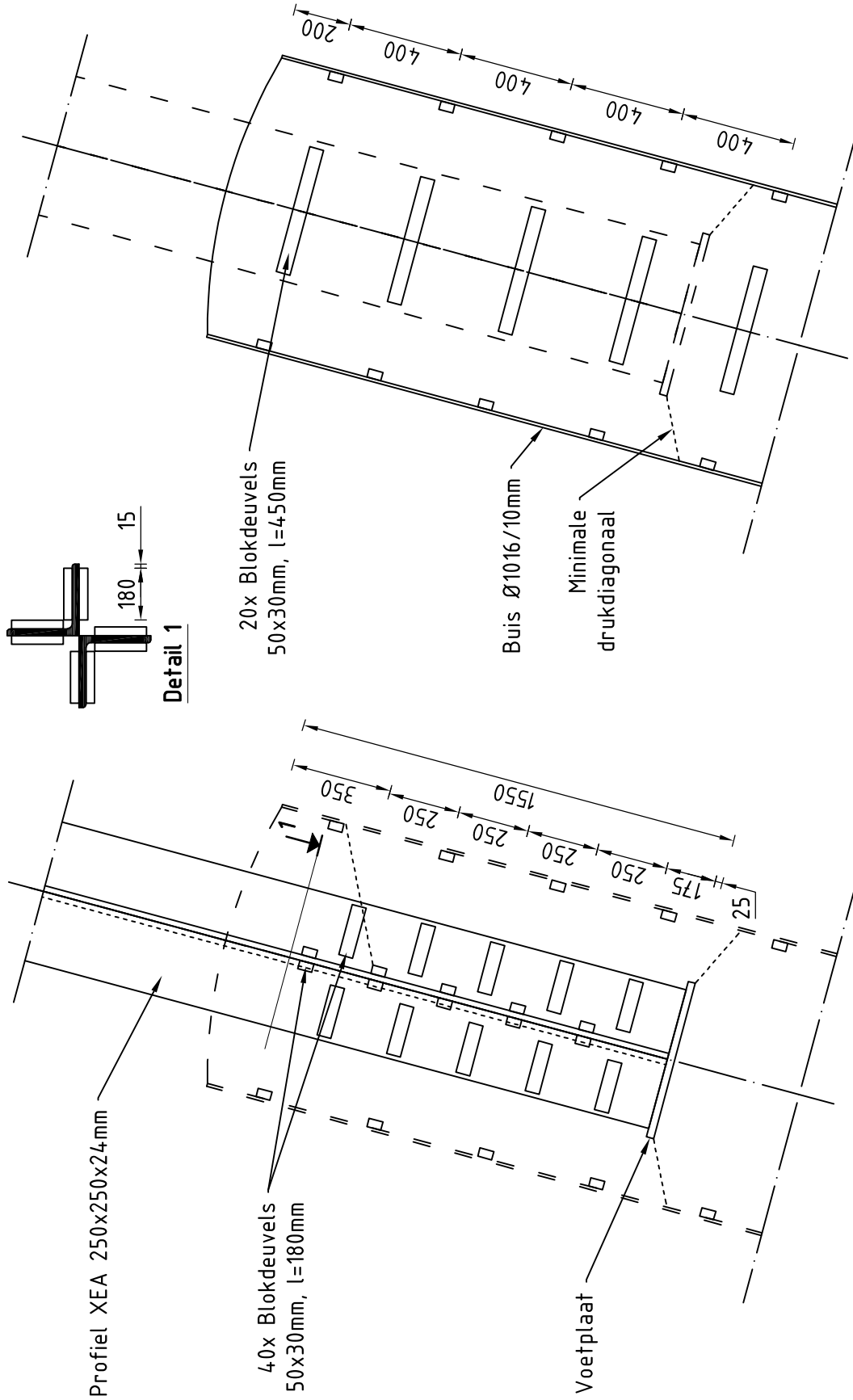

## Algemene opmerkingen

- Aarding niet aangegeven
- Spiraalwapening niet aangegeven



Project: RLL-TBG  
Mast: HA-B-C/c & WA-B/c & EA-co

**Shear blocks**

NEN-EN 1993-1-1 en NEN-EN 1994-1-1

Datum: 2021-07-09

Auteur: TBR

Versie: 1.5

Load			Results		
Compression	$F_{Ed,c}$	5600 kN	Compression	U.C.	0.87 < 1,00 OK
Tension	$F_{Ed,t}$	4800 kN	Tension	U.C.	0.78 < 1,00 OK

**Main leg**

Profile		<b>XEA 250x250x24</b>
Type		Double (XEA)
Steel material		S355
Cross section		22934 mm <sup>2</sup>
Axial capacity	$N_{pl}$	8142 kN
Width	b	500 mm
Thickness	t	24 mm
Length in concrete		1550 mm

**Capacity shear blocks main leg**

$A_{f1} = A_{f1,out} + A_{f1,in} =$	10800 mm <sup>2</sup>
$A_{f2} = A_{f2,out} + A_{f2,in} =$	31807.5 mm <sup>2</sup>
Slope	1 : 5
$C_A = \sqrt{(A_{f2}/A_{f1})} =$	1.72
$f_{jd} = C_A \times f_{cd} =$	25.8 N/mm <sup>2</sup>
$F_{Rd,c} = n_c \times A_{f1} \times f_{jd} =$	4459 kN
$F_{Rd,t} = n_t \times A_{f1} \times f_{jd} =$	4459 kN

**Shear blocks main leg**

Sides		2
Width	b	50 mm
Thickness	h	30 mm
Length - outside	$L_{out}$	180 mm
Length - inside	$L_{in}$	180 mm
Eccentricity	e	15 mm
Welds	a	5 mm
c.t.c. separation	s	250 mm
Number for compr.	$n_c$	16 -
Number for tension	$n_t$	16 -

**Capacity foot plate**

$k_d =$	1.73 -
$f_{jd} = C_A \times f_{cd} =$	26.0 N/mm <sup>2</sup>
$c = t\sqrt{(f_{yd} / 3f_{jd})} =$	53 mm
$m^* = \min(c, m) =$	30 mm
Type foot plate	Extending
Effective for	Compr. and tension
$A_{p,c} =$	86534 mm <sup>2</sup>
$F_{Rd,c} = A_{p,druk} \times f_{jd} =$	2254 kN
$A_{p,t} =$	63600 mm <sup>2</sup>
$F_{Rd,t} = A_{p,t} \times f_{jd} =$	1657 kN

**Foot plate**

Thickness	t	25 mm
Ext. length	m	30 mm
Welds	a	5 mm

**Capacities**

$F_{rd,c,plate} =$	2254 kN
$F_{rd,blocks,c} =$	4459 kN
$F_{rd,c} = F_{rd,blk} + F_{rd,footplate} =$	<b>6713 kN</b>
U.C. compression	0.83 < 1,00 OK
Welds foot plate (see next page)	2454 kN
$F_{rd,t} = \min. (\text{welds} / \text{foot plate}) =$	1657 kN
$F_{rd,blocks,t} =$	4459 kN
$F_{rd,t} = F_{rd,blk} + F_{rd,footplate} =$	<b>6116 kN</b>
U.C. tension	0.78 < 1,00 OK
U.C. welds	0.47 < 1,00 OK

**Pile**

Name		Buispaal
Diameter		1016 mm
Thickness		10 mm
Cross section		31604 mm <sup>2</sup>
Steel material		S355
Capacity		11220 kN
Concrete strength		C30/37

**Shear blocks pile**

Width	b	50 mm
Thickness	h	30 mm
Length	L	450 mm
Welds	a	5 mm
c.t.c. separation	s	400 mm
Number for compr.	$n_c$	16 -
Number for tension	$n_t$	16 -
Blocks per row	$n_{bl}$	4 -
Effectivity of total	$C_{red}$	100% -

**Capacity shear blocks pile**

$A_{f1} =$	13500 mm <sup>2</sup>
$A_{f2} =$	53076 mm <sup>2</sup>
$C_A = \sqrt{(A_{f2}/A_{f1})} =$	1.98 -
$f_{jd} = k_d \times f_{cd} =$	29.8 N/mm <sup>2</sup>
$F_{Rd,c} = n_c \times A_{f1} \times f_{jd} \times C_{red} =$	<b>6440 kN</b>
U.C. compression	0.87 < 1,00 OK
$F_{Rd,t} = n_t \times A_{f1} \times f_{jd} \times C_{red} =$	<b>6440 kN</b>
U.C. tension	0.75 < 1,00 OK
U.C. welds	0.45 < 1,00 OK

**Design value concrete strength**

Material factor	$\gamma_c$	1.5
Add. mat. factor	$\gamma_m$	1.33 -
$f_{cd} =$		15.0 N/mm <sup>2</sup>

**"Splitting" of pile**

Spread of forces		45 °
Length force flow		1052 mm
Splitting force		2281 kN/m
Yield strength wall	$f_{yd} =$	355 N/mm <sup>2</sup>
Capacity tubular pile		7100 kN/m
U.C.		0.32 < 1,00 OK

**Steel tower stub**

Yield strength	$f_{yd} =$	355 N/mm <sup>2</sup>
Tensile strength	$f_{ud} =$	490 N/mm <sup>2</sup>

Project: RLL-TBG  
 Mast: HA-B-C/c & WA-B/c & EA-co

### Welds of shear blocks of main leg

Out-of-plane loading

#### Plate

t = 50 mm  
 Grade S355  
 $f_{yd} = 355 \text{ N/mm}^2$   
 $f_u = 490 \text{ N/mm}^2$

#### Member forces

Factor 1.2  
 $F_{t,Ed} = 0 \text{ kN}$   
 $F_{v,Ed} = F_{rd,c} / n = 334 \text{ kN}$   
 $F_{v//,Ed} = 0 \text{ kN}$   
 $M_{Ed} = 1/2 b / h \times F_{v,Ed} = 5.02 \text{ kNm}$

#### Check

$\sigma_{w,Ed} = 203 \text{ N/mm}^2 \leq$   
 $\sigma_1 = 102 \text{ N/mm}^2 \leq$

#### Welds

a = 5 mm  
 l = 360 mm  
 $\beta_w = 0.9 -$   
 $\gamma_{M2} = 1.25 -$

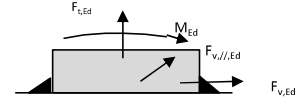

#### Stress components

$\sigma_1 = \tau_1 = F_{t,Ed} \sqrt{2} / 4al = 0 \text{ N/mm}^2$   
 $\sigma_1 = \tau_1 = F_{v,Ed} \sqrt{2} / 4al = 66 \text{ N/mm}^2$   

---

 $66 \text{ N/mm}^2$   
 $b^* = b + 2/3av^2 = 54.7 \text{ mm}$   
 $\sigma_1 = \tau_1 = 0.706M_{Ed} / al b^* = 36 \text{ N/mm}^2$   
 $\tau_{//} = F_{v//,Ed} / 2al = 0 \text{ N/mm}^2$   
 $\sigma_{w,Ed} = \sqrt{(\sigma_1^2 + 3\tau_1^2 + 3\tau_{//}^2)} = 203 \text{ N/mm}^2$

$f_u / \beta_w \gamma_{M2} = 436 \text{ N/mm}^2$  U.C. = **0.47 OK**  
 $0.9f_u / \gamma_{M2} = 353 \text{ N/mm}^2$  U.C. = **0.29 OK**

### Welds of shear blocks of pile

Out-of-plane loading

#### Plate

t = 50 mm  
 Grade S355  
 $f_{yd} = 355 \text{ N/mm}^2$   
 $f_u = 490 \text{ N/mm}^2$

#### Member forces

Factor 1.2  
 $F_{t,Ed} = 1/2 b / h \times F_{v,Ed} = 145 \text{ kN}$   
 $F_{v,Ed} = 483 \text{ kN}$   
 $F_{v//,Ed} = 0 \text{ kN}$   
 $M_{Ed} = 0.00 \text{ kNm}$

#### Check

$\sigma_{w,Ed} = 197 \text{ N/mm}^2 \leq$   
 $\sigma_1 = 99 \text{ N/mm}^2 \leq$

#### Welds

a = 5 mm  
 l = 450 mm  
 $\beta_w = 0.9 -$   
 $\gamma_{M2} = 1.25 -$

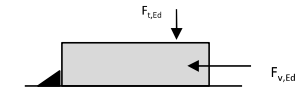

#### Stress components

$\sigma_1 = \tau_1 = F_{t,Ed} \sqrt{2} / 2al = 23 \text{ N/mm}^2$   
 $\sigma_1 = \tau_1 = F_{v,Ed} \sqrt{2} / 2al = 76 \text{ N/mm}^2$   

---

 $76 \text{ N/mm}^2$   
 $\tau_{//} = F_{v//,Ed} / 2al = 0 \text{ N/mm}^2$   
 $\sigma_{w,Ed} = \sqrt{(\sigma_1^2 + 3\tau_1^2 + 3\tau_{//}^2)} = 197 \text{ N/mm}^2$

$f_u / \beta_w \gamma_{M2} = 436 \text{ N/mm}^2$  U.C. = **0.45 OK**  
 $0.9f_u / \gamma_{M2} = 353 \text{ N/mm}^2$  U.C. = **0.28 OK**

### Welds of foot plate

$f_u / \beta_w \gamma_{M2} = 436 \text{ N/mm}^2$   
 Weld size a = 5 mm  
 Length l = 2b + 2b - t = 1952 mm  
 Capacity  $F_{Rd} = a \times l \times f_{w,d} / \sqrt{3} = 2454 \text{ kN}$



## **APPENDIX E**

### **Liggers**

---

## 1 BEREKENING OPHANGING POSTISOLATOREN

De volgende onderdelen worden berekend:

- De belastingen op de ophanging van de postisolatoren door wind en eigen gewicht;
- De dimensionering van de ophangconstructies.

Onderstaand zijn de optredende belastingen geschematiseerd:

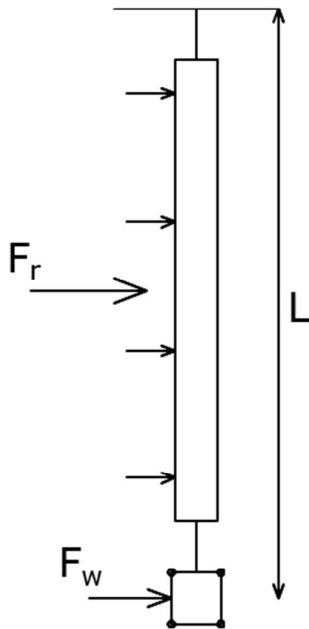

**Figuur 1** Belastingenschema

### 1.1 Uitgangspunten & afmetingen postisolatoren

Voor het berekenen van de liggers voor de ophanging van de postisolatoren in de mastkoppen van de HA-masten wordt één berekening gemaakt met de volgende uitgangspunten:

- Windgebied II;
  - Windhoogte 54,5m (gebaseerd op hoogste mast HB+6/c);
  - Onbebouwd;
- Referentieperiode 50 jaar;
- Belastingfactor 1,5.

De volgende factoren worden gehanteerd:

- Krachtcoëfficiënt 1,2 voor isolatoren
- Constructiefactor geleider 1,0;
- Krachtcoëfficiënt geleider 1,0;
- Constructiefactor geleider 1,0.

Conform het uitgangspuntendocument zijn de afmetingen als volgt:

**Tabel 1 Gegevens postisolatoren**

Omschrijving	Ophanging	Gewicht [kN]	Lengte [m]	Windopp. [m]
Fasegeleider 380 kV	Bretelfixatie	2,0	4,5	1,0
Fasegeleider 150 kV	Bretelfixatie	1,5	2,7	0,7

De diameter van de geleiders is 32mm.

## 1.2 Belastingen

De extreme stuwdruk  $q_{p(z)}$  in windgebied II op een hoogte van 54,5m is 1,41 kN/m<sup>2</sup>.

Er komen drie varianten voor:

1. 380 kV geleider met één postisolator;
  - Lengte geleider aan postisolator ca. 9 m;
2. 150 kV geleider met één postisolator;
  - Lengte geleider aan postisolator ca. 7 m;
3. 150 kV geleider met twee postisolatoren;
  - Lengte geleider aan postisolator ca. 3,5 m.

In het horizontale vlak bestaat er een afstand tussen het uiteinde van de afspanketting en de postisolator (zie figuur 2). Dit veroorzaakt een extra horizontale kracht vanuit de bretelle op de onderzijde van de postisolator (zie figuur 3). Het gewicht van de bretelle (380kV) is gelijk aan ( $4 \times 17,7\text{N/m} = 70,8\text{N/m}$ ). De horizontale kracht evenwijdig aan de brettelle is gelijk aan:

$$\bullet F_{h,evenw} = \frac{1}{8} \cdot q \cdot L^2 / u = \frac{1}{8} \cdot 0,0708\text{kN/m} \cdot (7,62\text{m})^2 / 1,2\text{m} = 0,4 \text{ kN.}$$

De horizontale kracht loodrecht op de postisolator is gelijk aan:

$$\bullet F_{h,gel} = 2 \cdot 0,4\text{kN} \cdot 3,75\text{m} / 7,62\text{m} = 0,4 \text{ kN.}$$

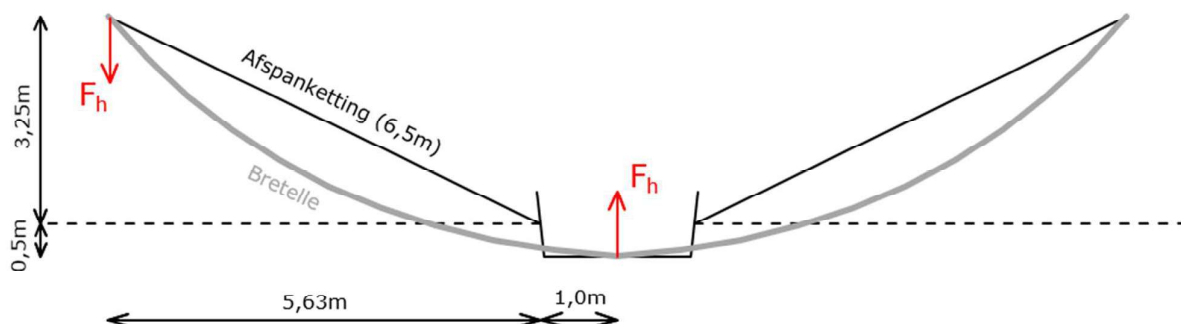

**Figuur 2 Bovenanzicht bretelle**

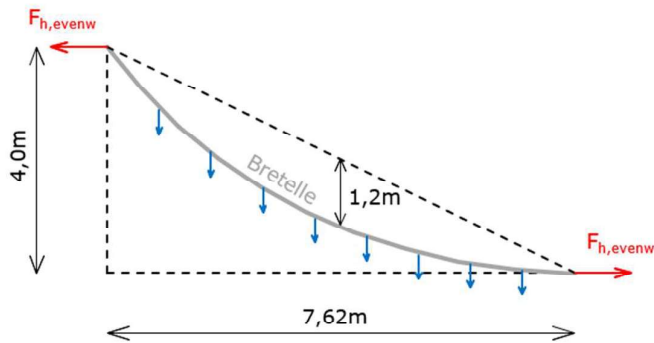

Figuur 3 Zij-aanzicht bretelle

Voor het 180kV-circuit wordt dezelfde berekening gemaakt. De afspanketting heeft een lengte van 4,0m en de tussen afstand is 2 x 2m (i.p.v. 2 x 1m). De postisolator hangt 1,0m naar buiten en de horizontale afstand (ten gevolge van de hoek) is gelijk aan  $(\sin(30^\circ) \cdot 4m =) 2m$ . De lengte is dan gelijk aan  $(\sqrt{((\cos(30^\circ) \cdot 4m + 2m)^2 + (2m + 1m)^2}) = 6,23m$ . De krachten zijn dan gelijk aan:

- $F_{h,evenw} = \frac{1}{8} \cdot q \cdot L^2 / u = \frac{1}{8} \cdot 0,0354kN/m \cdot (6,23m)^2 / 0,8m = 0,2 \text{ kN};$
- $F_{h,gel} = \frac{2 \cdot 0,4kN \cdot 3,0m}{6,23m} = 0,2 \text{ kN}.$

Belasting bij wind loodrecht op de geleider

Voor elke variant zijn in onderstaande tabellen de optredende reactiekrachten ( $F_h$ ,  $F_{v,tot}$  en  $M_{tot}$ ) op het ophangpunt van de postisolator berekend.

**Tabel 2 Optredende belastingen per variant – wind loodrecht**

Var.	$q_p(z)$ [kN/m <sup>2</sup> ]	$G_{post}$ [kN]	$L_{post}$ [m]	Opp [m <sup>2</sup> ]	$n_{gel}$ [n]	$\emptyset_{gel}$ [m]	$G_{gel}$ [kN/m]	$L_{gel}$ [m]	$F_{h,gel}$ [kN]
1	1,41	2	4,5	1	4	0,032	0,0177	9	0,4
2	1,41	1,5	2,7	0,7	2	0,032	0,0177	7	0,2
3	1,41	1,5	2,7	0,7	2	0,032	0,0177	3,5	0,1

Var.	$C_{f,r}$ [-]	$S_r$ [-]	$F_{r,k}$ [kN]	$M_{r,k}$ [kNm]	$C_{f,w}$ [-]	$S_w$ [-]	$F_{w,k}$ [kN]	$M_{w,k}$ [kNm]
1	1,2	1	1,69	3,81	1	1	1,62	7,31
2	1,2	1	1,18	1,60	1	1	0,63	1,71
3	1,2	1	1,18	1,60	1	1	0,32	0,85

Var.	$\gamma$ [-]	$F_{v,Ed}$ [kN]	$F_{h,tot,Ed}$ [kN]	$M_{tot,Ed}$ [kNm]
1	1,5	4,0	5,6	19,4
2	1,5	2,6	3,0	5,8
3	1,5	2,4	2,4	4,1

Belasting bij wind evenwijdig aan de geleider

Waar relevant wordt er ook getoetst aan wind evenwijdig aan de geleider. In onderstaande tabel zijn de optredende krachten weergegeven.

**Tabel 3 Optredende belastingen per variant – wind evenwijdig**

Var.	L <sub>post</sub> [m]	F <sub>h,gel</sub> [kN]	M <sub>r,-,k</sub> [kNm]	F <sub>r,k</sub> [kN]	M <sub>r,/,k</sub> [kNm]	F <sub>v,Ed</sub> [kN]	F <sub>h,-,Ed</sub> [kN]	M <sub>r,-,Ed</sub> [kNm]	F <sub>h,/,Ed</sub> [kN]	M <sub>r,/,Ed</sub> [kNm]
1	4,5	0,4	1,8	1,69	3,81	4,0	0,6	2,7	2,5	5,7
2	2,7	0,2	0,54	1,18	1,60	2,6	0,3	0,8	1,8	2,4
3	2,7	0,1	0,27	1,18	1,60	2,4	0,2	0,4	1,8	2,4

## 2 VARIANT 1 – 380 KV – 1 POSTISOLATOR

De ophanging van de postisolator bij variant 1 kent twee varianten:

- A. Ophanging aan enkele ligger (onderstaand links);
- B. Ophanging aan frame (onderstaand rechts).

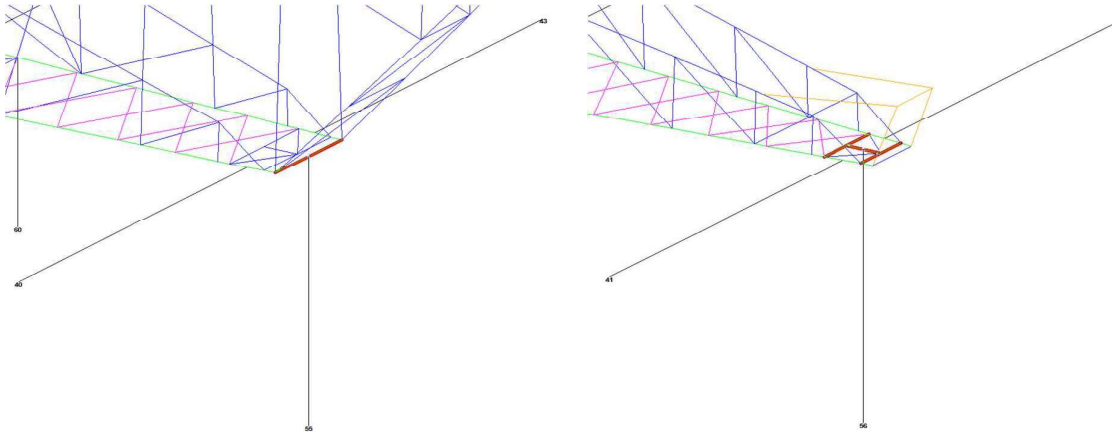

**Figuur 4** Principe ophanging variant 1A (links) en 1B (rechts)

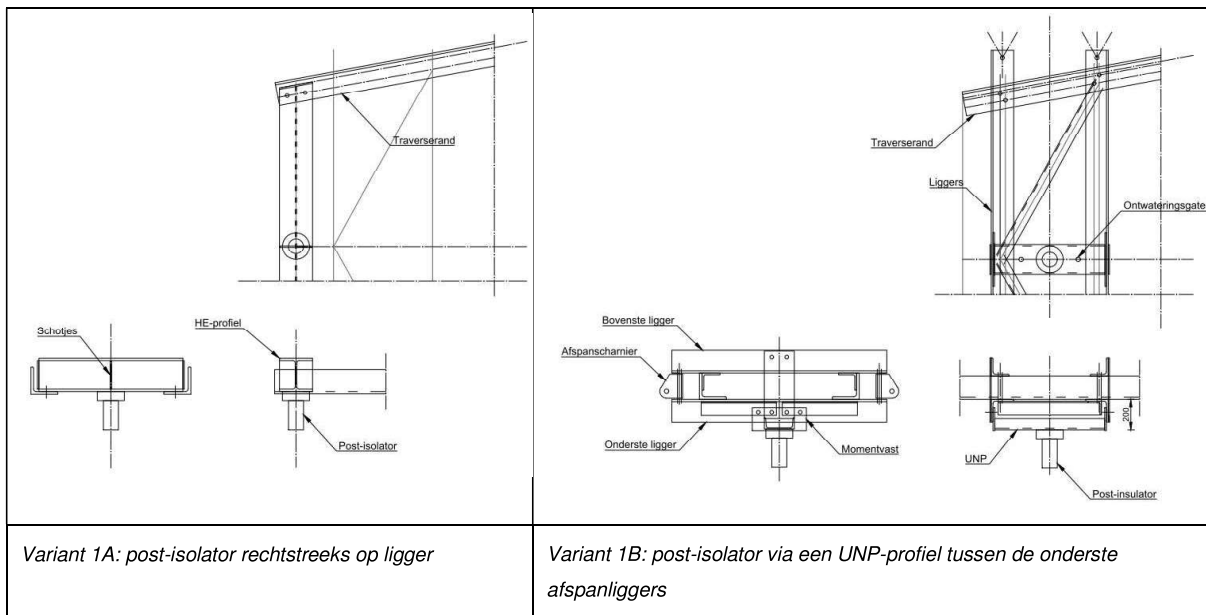

**Figuur 5** Principedetails voor bevestiging post-insulator variant 1A en 1B



## 2.1 Variant A

De postisolator wordt opgehangen aan een enkele stalen ligger. Deze ligger wordt daardoor in twee richtingen en op torsie belast. De optredende belastingen zijn:

- Verticaal  $F_v$  4,0 kN;
- Horizontaal  $F_{h,tot}$  5,6 kN;
- Torsiemoment  $M_{tot}$  19,4 kNm.

De maximale lengte van de ligger is 1,82m (boventraverse). Het profiel van de ligger is HEB220 (S355). De ligger wordt getoetst aan de hand van een excel-sheet. Uit berekening blijkt dat de ligger voldoet met een maximale UC van 0,78. Voor berekening, zie na pagina 6.

## 2.2 Variant B

Onderstaand is de situatie schematisch weergegeven. De hoeklijnen hebben een (minimale) doorsnede van 150x150x14mm. De afstand tussen de hoeklijnen is minimaal 600 mm. De bovenste en onderste hoeklijnen worden halverwege de overspanning gekoppeld.

De optredende maximale reactiekracht is gelijk aan  $(4,0\text{kN}/2 + 19,4\text{kNm}/0,6\text{m}) = 34,3\text{kN}$ . Per ligger is de kracht gelijk aan  $(34,3\text{kN} / 2) = 17,2\text{kN}$ .

De maximale overspanning is 2,5m (middentraverse → 150kV heeft langste ligger, deze als maatgevend aangehouden). Het totale moment in het hoekstaal wordt dan  $(0,25 \cdot (17,2\text{kN} + 5,3\text{kN}/2) \cdot 2,5\text{m}) = 12,4\text{kNm}$ .

Het weerstandsmoment is gelijk aan  $83500\text{mm}^3$ . De spanning is gelijk aan  $(12,4 \cdot 10^6 \text{ Nmm} / 83500\text{mm}^3) = 158\text{MPa}$ . De ligger voldoet met een UC van  $(158\text{MPa} / 355\text{MPa}) = 0,45$ .

De ligger die hoeklijnen koppelt heeft een doorsnede van UNP220 en wordt om de zwakke as belast. Het optredende moment is gelijk aan  $(1/4 \cdot 4,0\text{kN} \cdot 0,6\text{m} + 1/2 \cdot 19,4\text{kNm}) = 10,3\text{kNm}$ . De spanning is gelijk aan  $(10,3 \cdot 10^6 \text{ Nmm} / 33500\text{mm}^3) = 307\text{MPa}$ . De ligger voldoet met een UC van  $(307\text{MPa} / 355\text{MPa}) = 0,86$ .

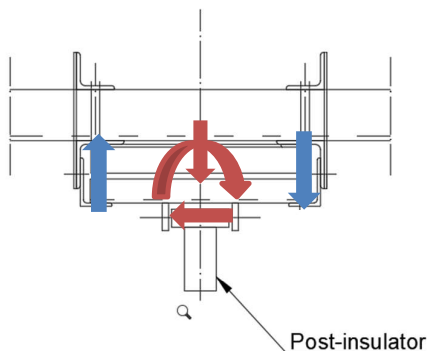

Figuur 6 Schematische weergave ophanging variant 1B

### 3 VARIANT 2 – 150 KV – 1 POSTISOLATOR

Bij deze variant wordt de postisolator opgehangen aan een frame, dit komt overeen met variant 1B. De optredende belastingen zijn:

- Verticaal  $F_v$  2,6 kN;
- Horizontaal  $F_{h,tot}$  3,0 kN;
- Torsiemoment  $M_{tot}$  5,8 kNm.

De belastingen zijn lager en de liggers maximaal even lang als bij variant 1B. Voor variant 2 voldoen profielen 150x150x14mm dus ook, voor uitwerking zie variant 1B.

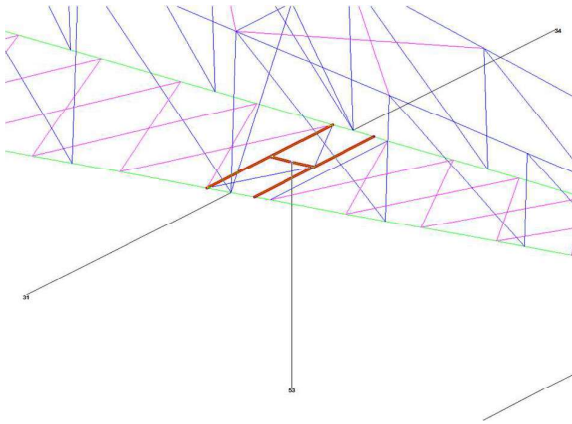

**Figuur 7 Principe ophanging variant 2**

## 4 VARIANT 3 – 150 KV – 2 POST-ISOLATOR

De postisolator wordt via een verlaagde console ingeklemd in twee richtingen opgehangen aan de onderrand van de traverse. De torsie op de onderrand wordt opgenomen door een ligger uit HE-profiel (diagonalen worden verwaarloosd), in de richting van de onderrand neemt de rand de momenten op. De optredende belastingen zijn:

- Verticaal  $F_v$  2,4 kN;
- Horizontaal  $F_{h,tot}$  2,4 kN;
- Torsiemoment  $M_{tot}$  4,1 kNm.

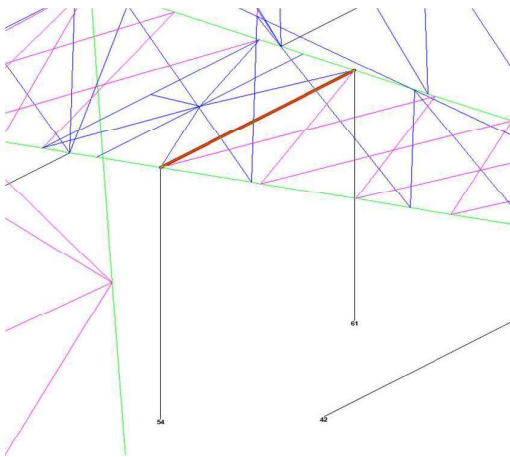

Figuur 8 Principe ophanging variant 3

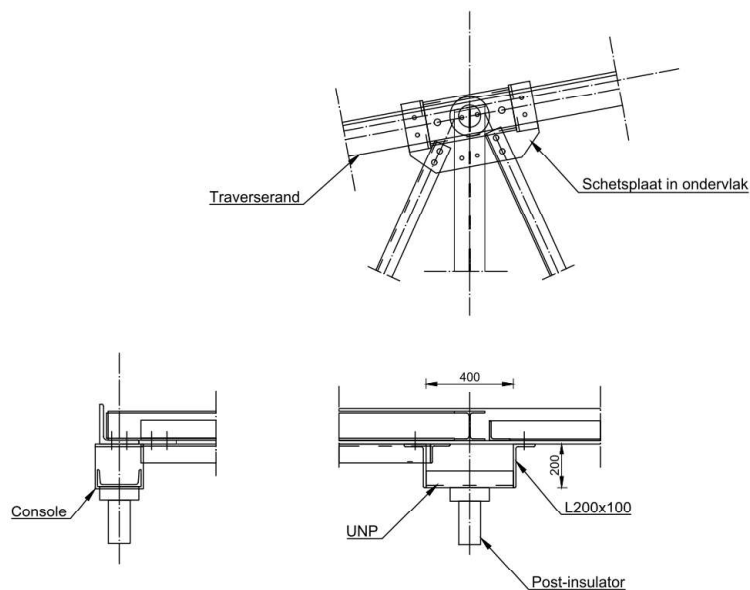

Figuur 9 Principedetail bevestiging post-isolator aan rand

De ligger wordt belast door een kopmoment. Dit moment is volgens Tabel 3 gelijk aan 2,4 kNm. Ligger met praktisch gekozen profiel HE140A volstaat.

Kritisch aspect in de verbinding is de krachtsoverdracht van het buigend moment uit het vlak van de console naar de ligger. De onderrand wordt lokaal (tussen de console en HE-ligger) op torsie belast en de flens van het hoekprofiel

wordt ook op buiging belast. Om de krachtsinleiding mogelijk te maken wordt de onderrand verstijfd met een schetsplaat waarmee de HE-ligger en diagonalen worden verbonden.

De controle is uitgevoerd met het programma AxisVM. Zowel buiging in het vlak als buiging uit het vlak is gecontroleerd. Als minimaal profiel van de onderrand is uitgegaan van L150x150x14. De maximale drukkracht in de rand is in combinatie met de buiging meegenomen.

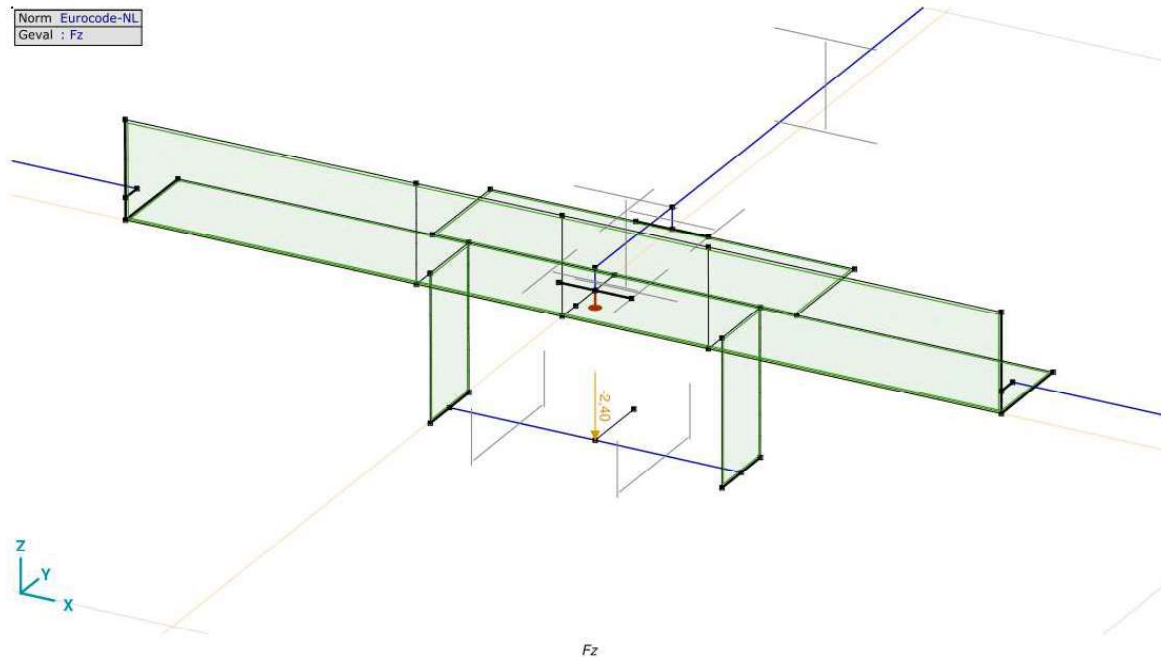

**Figuur 10 Rekenmodel krachtsinleiding post-isolator aan onderrand**

De belastingen zijn ontleend aan Tabel 2 en Tabel 3 voor de 150 kV post-isolator. De belastingen zijn in AxisVM gecombineerd met het verticale gewicht, en met twee richtingen van  $M_x$  en  $M_y$ , waarbij belastinggevallen zijn vermindert tot een factor 0,71.

**Tabel 4 Belastingen op console**

Var.	$F_{z,Ed}$ [kN]	$F_{x,Ed}$ [kN]	$F_{y,Ed}$ [kN]	$M_{x,Ed}$ [kNm]	$M_{y,Ed}$ [kNm]
$M_x$			1,8	2,4	
$M_y$		3,0			5,8
Fz	2,4				
N	600				

Uit de berekening blijkt dat de combinatie van spanningen door torsie en buiging toelaatbaar is.

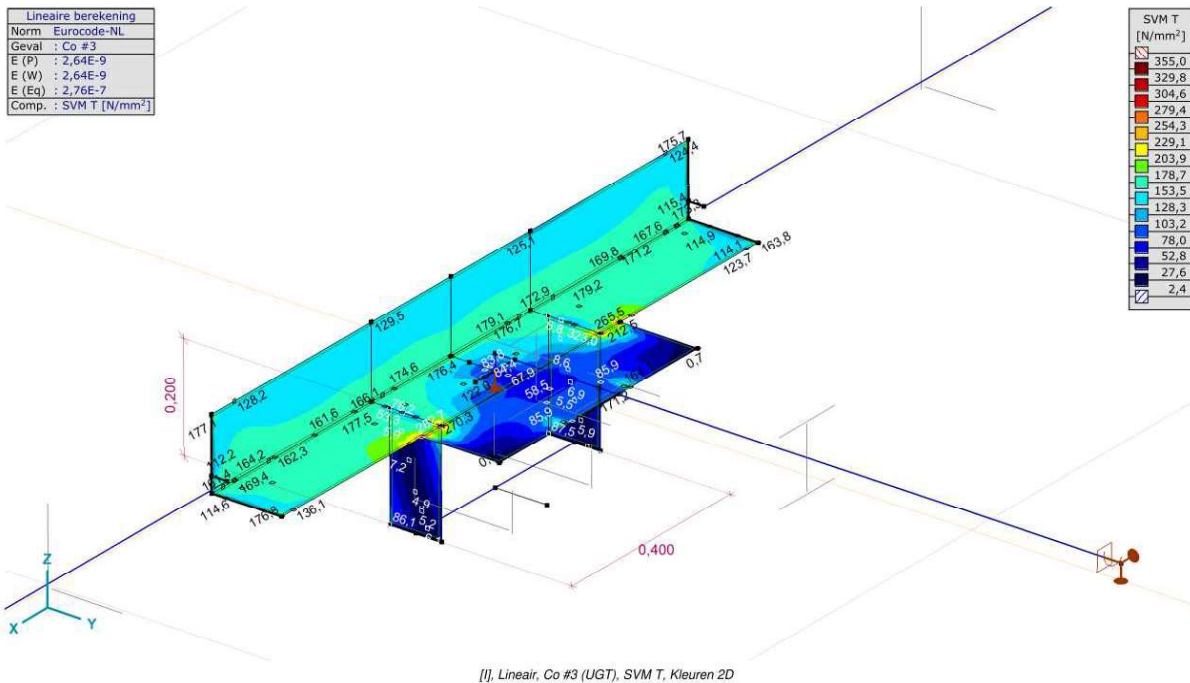

**Figuur 11 Spanningen in de maatgevende belastingcombinatie**

In het model treden elastisch berekend bij hoeken spanningsconcentraties op. Zie Figuur 11. In de uitvoer opgenomen in de bijlage blijkt dat de hoogste spanning 323 N/mm<sup>2</sup> bedraagt. De toetsing is:

$$U.C. = 323 \text{ N/mm}^2 / 355 \text{ N/mm}^2 = 0,91 \leq 1,00 \text{ OK.}$$

De staalprofielen voldoen.

## 5 CONTROLE AFSPANLIGGERS

De afspankettingen van de hoekmast worden bevestigd tussen twee paren van hoekprofielen. De liggers worden belast op buiging in het geval van een lijnhoek. Als gevolg van de belasting van het afspanscharnier wordt het hoekprofiel ook op lokale buiging belast.

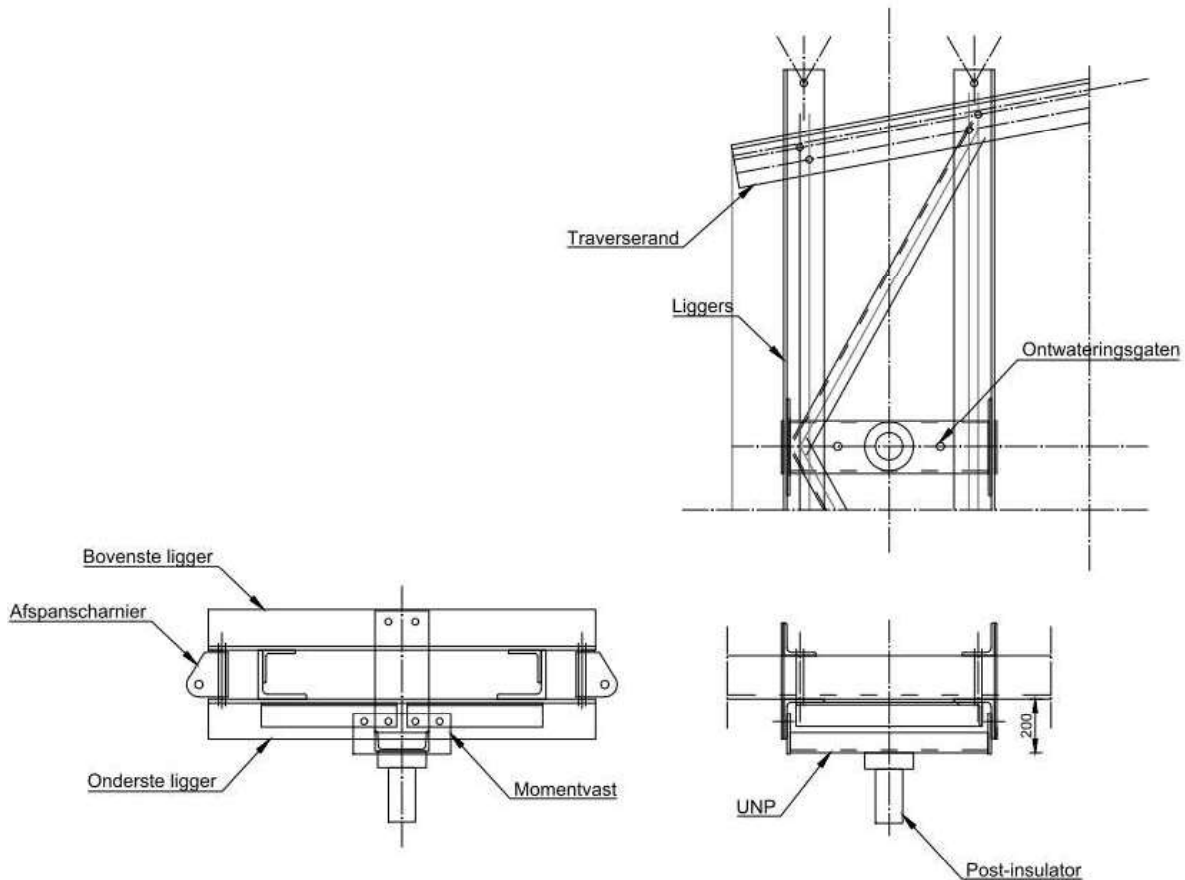

**Figuur 12 Principe van de afspanliggers. De uitragende ligger wordt in het geval van een lijnhoek op buiging belast door de kracht uit de afspanketting**

De profielen worden gecontroleerd op buiging met het programma AxisVM, de profielen worden geschematiseerd met plaalementen.

Vanwege uniformiteit over de masttypes in afspanscharnieren wordt de controle uitgevoerd op basis van het masttype met de grootste lijnhoek en de grootste uitkraging. Dit is de HC+0-mast van het solo-type, omdat de ondertraverse de grootste breedteverandering heeft, met bijbehorend grootste uitkraging.

In het DO zal de verbinding verder in detail worden gecontroleerd. Omdat de plaatbuiging bepalend is voor het profiel dat wordt toegepast, wordt nu de controle van de liggers op buiging uitgevoerd.

Twee profielen worden gecontroleerd: het profiel voor de 150 kV-afspankettingen (L150x150x14) en het profiel voor de 380 kV-afspankettingen (L150x150x18).

Voorlopig worden bovenste en onderste ligger gelijk genomen, in UO-fase kan de bovenste ligger nog geoptimaliseerd worden omdat deze niet door de verticale belasting belast wordt.

Schema

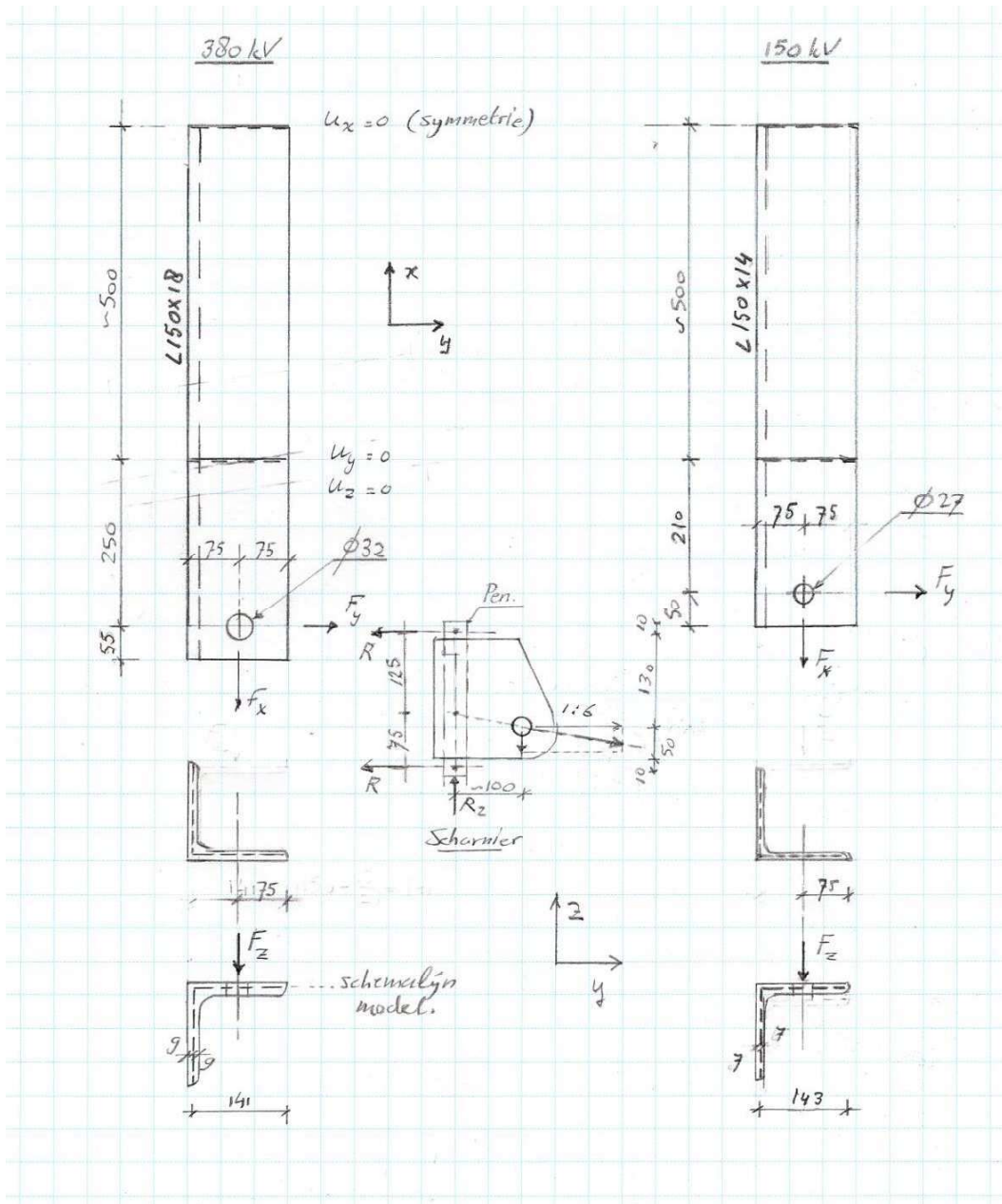

**Figuur 13 Schematisering liggers**

De helft van de ligger wordt berekend met symmetrie randvoorwaarden. De zwaartelij van de plaatdikte is het uitgangspunt voor de geometrie. De verbinding met de traverserand wordt vereenvoudigd tot een lijnoplegging aan de bovenflens met fixatie van y- en z-richting. De berekening is lineair-elastisch.

**Tabel 5 Geleiderbelastingen**

Belastingcombinatie	Spanning	Fxtotaal	Fytotaal	Fztotaal	Ftrekhead
ULS_3_120	380 kV	220,0	142,3	44,4	261,6
	150 kV	109,9	71,0	22,2	130,7

De belastingen worden omgezet naar een lijnlast rondom het gat voor de pen. De x- en y-belasting op de helft van de omtrek, de verticale belasting (z-richting) rondom de gehele omtrek.

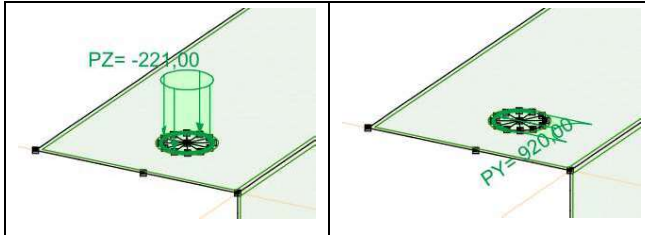

**Figuur 14 Invoer van belastingen als lijnlast rondom boutgat**

De belasting van Tabel 5 wordt verdeeld over twee kettingen. Vanwege de geometrie van het afspanscharnier wordt circa 65% van de belasting verdeeld naar de onderste ligger.

**Tabel 6 Schematisering belasting**

	d (mm)	Omtrek bij Fx (mm)	Omtrek bij Fy (mm)	Omtrek bij Fz (mm)
380 kV	32	50,3	50,3	100,5
150 kV	27	42,4	42,4	84,8
Verhouding afdracht		0,65	0,65	1

De lijnbelasting wordt berekend met:

$$q = 1/2 \cdot k \cdot F / O$$

In Tabel 7 zijn de lijnlasten berekend met bovenstaande formule. Deze zijn in AxisVM ingevoerd.

**Tabel 7 lijnlast rond gat**

	qx (kN/m)	qy (kN/m)	qz (kN/m)
380 kV	1422	920	221
150 kV	842	544	131



## Toetsing

Zie de uitvoer van AxisVM. De combinatie van buiging en lokale buiging op het bovenzvlak van het hoekprofiel ter plaatse van de lijnoplegging is maatgevend.

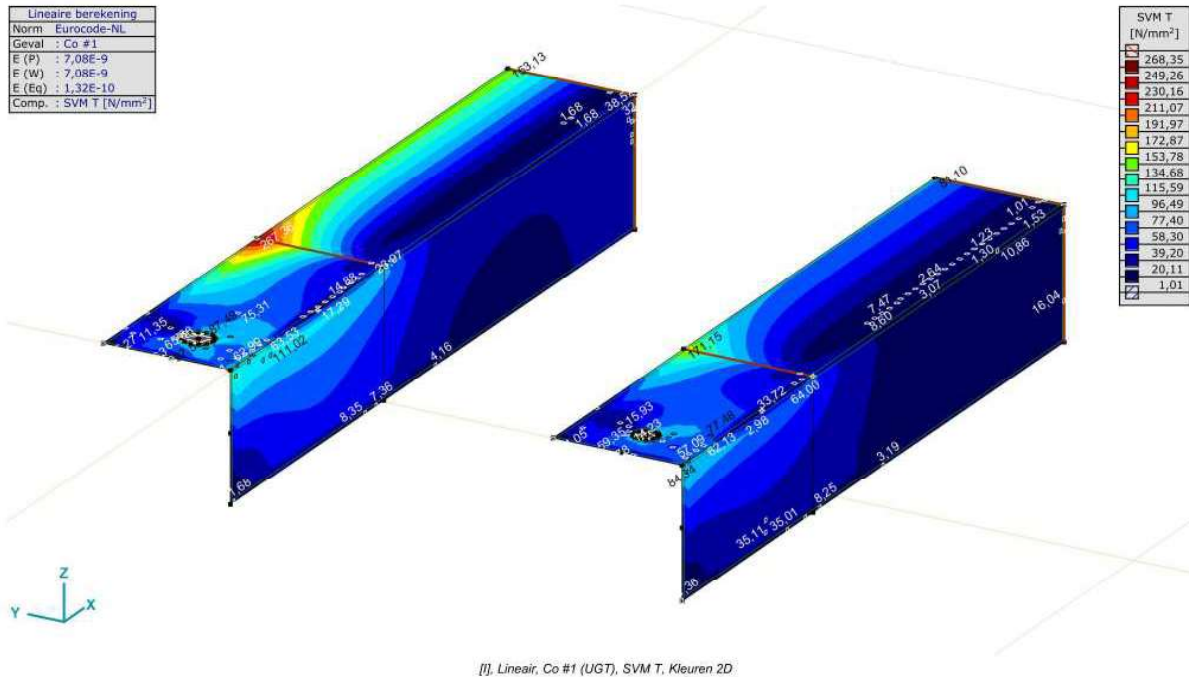

**Figuur 15 Maximale spanning in hoekprofiel voor 380 kV en 150 kV**

Toetsing:

L150x18: U.C. :  $267 / 355 = 0,75 \leq 1,00$  OK

L150x14: U.C. :  $171 / 355 = 0,48 \leq 1,00$  OK

De profielen voldoen.

## **Project:**

**Constructeur: DNV GL - Energy**

AxisVM X5 R4h - Geregistreerd aan DNV GL - Energy  
Post aan onderstrand HA\_s,axs



**Rapport**

## Rapport, Inhoudsopgave

Onderdeel		Pagina	Onderdeel	Pagina
Materialen		3	[I], Linear, Omhullende (Alle UGT), Tx, Lijnen (gevuld)	22
Knoppen en staven		4	[I], Linear, Co #1 (UGT), eR, Lijnen	23
Dikte		5	[I], Linear, Co #2 (UGT), eR, Lijnen	24
Profielen		6	[I], Linear, Co #3 (UGT), eR, Lijnen	25
Domeinen		7	[I], Linear, Co #4 (UGT), eR, Lijnen	26
Knooppieggingen		7	[I], Linear, Co #5 (UGT), eR, Lijnen	27
Mx: Knoopbelastingen		8	[I], Linear, Co #6 (UGT), eR, Lijnen	28
Mx		9	[I], Linear, Co #1 (UGT), SVM T, Kleuren 2D	29
My: Knoopbelastingen		10	[I], Linear, Co #2 (UGT), SVM T, Kleuren 2D	30
My		11	[I], Linear, Co #3 (UGT), SVM T, Kleuren 2D	31
Fz: Knoopbelastingen		12	[I], Linear, Co #4 (UGT), SVM T, Kleuren 2D	32
Fz		13	[I], Linear, Co #5 (UGT), SVM T, Kleuren 2D	33
N: Knoopbelastingen		14	[I], Linear, Co #6 (UGT), SVM T, Kleuren 2D	34
N		15	[I], Linear, Omhullende (Alle UGT), SVM B, Iso vlakken 3D	35
Gebruiker gedefinieerde belastingcombinaties uit belastinggevallen		16	[I], Linear, Omhullende (Alle UGT), SVM C, Iso vlakken 3D	36
[I], Linear, Omhullende (Alle UGT), Nx, Lijnen (gevuld)		17	[I], Linear, Omhullende (Alle UGT), SVM T, Iso vlakken 3D	37
[I], Linear, Omhullende (Alle UGT), My, Lijnen (gevuld)		18	Vlakspanningen [Linear, Omhullende (Alle UGT)]	38
[I], Linear, Omhullende (Alle UGT), Mz, Lijnen (gevuld)		19	[I], Linear, Omhullende (Alle UGT), S;x:minmax, Lijnen (gevuld)	39
[I], Linear, Omhullende (Alle UGT), Vz, Lijnen (gevuld)		20	Staatspanningen [Linear, Omhullende (Alle UGT)]	40
[I], Linear, Omhullende (Alle UGT), Vy, Lijnen (gevuld)		21	Interne krachten knooppiegging [Linear, Omhullende (Alle UGT)]	41

**Project:**  
 Constructeur: DNV GL - Energy  
 Model: Post aan onderrand HA\_s.axes

Materialen

Naam	Type	Nationale norm	Materiaalnorm	Model	$E_x$ [N/mm <sup>2</sup> ]	$E_y$ [N/mm <sup>2</sup> ]	$E_z$ [N/mm <sup>2</sup> ]	$\nu$	$\alpha_T$ [1/°C]	$\rho$ [kg/m <sup>3</sup> ]	Materiaal kleur	Contour kleur	Structuur	$P_1$
I S 355	Staal	Eurocode-NL	10025-2	Lineair	210000	210000	210000	0,30	1,2E-5	7850				$f_y$ [N/mm <sup>2</sup> ] = 355,00

Naam	$f_{t1}$ [N/mm <sup>2</sup> ]	$P_2$	$P_3$	$P_4$	$P_5$	$P_6$	$P_7$	$P_8$	$P_9$	$P_{10}$	$P_{11}$	$P_{12}$	$P_{13}$	$P_{14}$
I S 355	$f_{t1}$ [N/mm <sup>2</sup> ] = 510,00													

**Naam:** Materiaalnaam; **Type:** Type materiaal; **Model:** Materiaal model; **E<sub>x</sub>:** Elasticiteitsmodulus in lokale x richting; **E<sub>y</sub>:** Elasticiteitsmodulus in lokale y richting; **E<sub>z</sub>:** Elasticiteitsmodulus in lokale z richting;  **$\nu$ :** Poisson's verhouding;  **$\alpha_T$ :** Warmteuitzettingscoëfficiënt;  **$\rho$ :** Dichtheid; **Materiaal kleur:** Materiaalkleur;

**Contour kleur:** Contourkleur; **P<sub>1</sub>, P<sub>2</sub>, P<sub>3</sub>, P<sub>4</sub>, P<sub>5</sub>, P<sub>6</sub>, P<sub>7</sub>, P<sub>8</sub>, P<sub>9</sub>, P<sub>10</sub>, P<sub>11</sub>, P<sub>12</sub>, P<sub>13</sub>, P<sub>14</sub>:** Ontwerpparameter;

**Project:**

Constructeur: DNV GL - Energy

Model: Post aan onderrand HA\_s.axes

Norm Eurocode-NL  
Geval : Fz

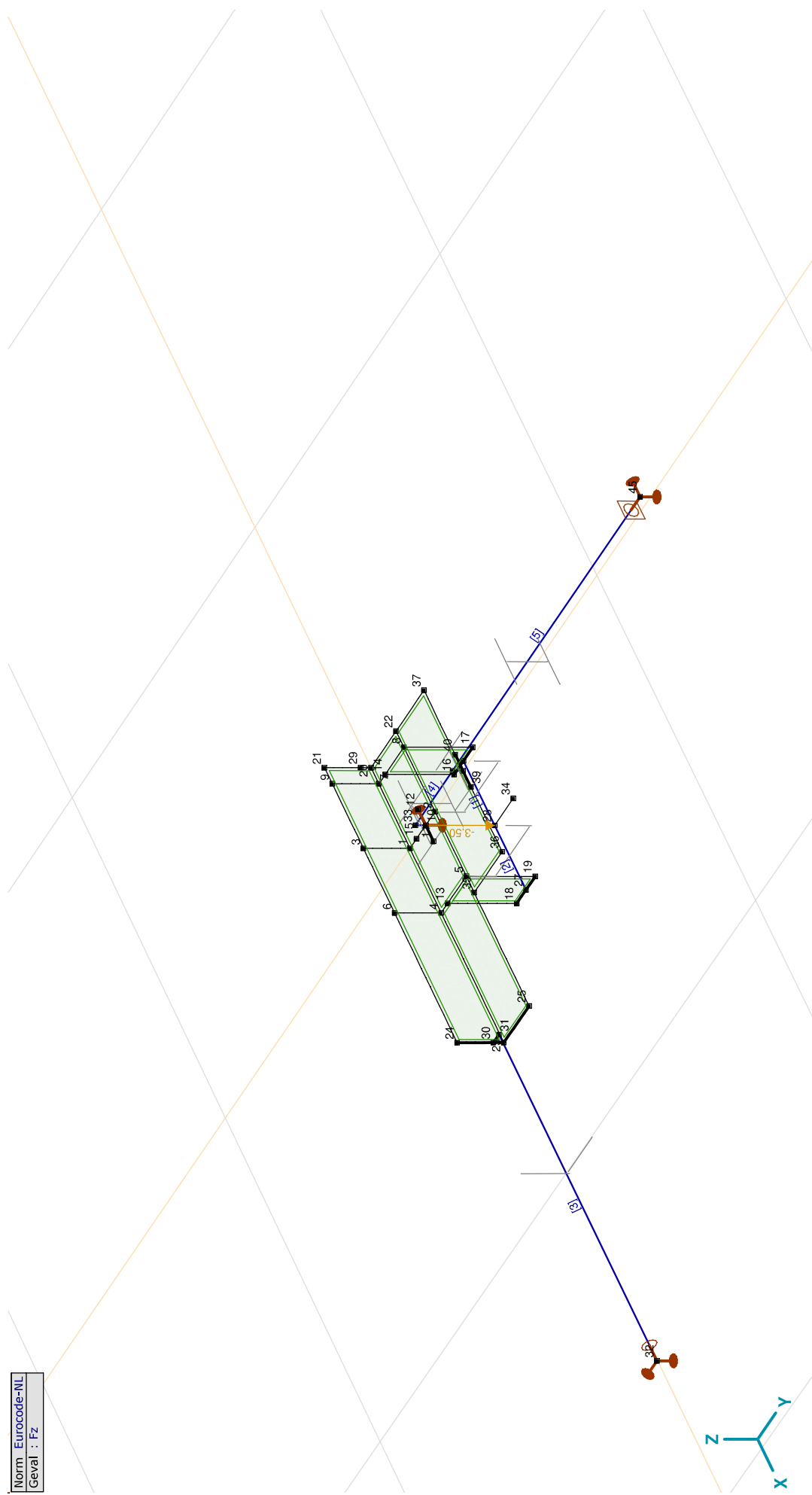

*Knoppen en staven*

**Project:**

Constructeur: DNV GL - Energy

Model: Post aan onderrand HA\_s.axes

Norm Eurocode-NL
Geval : N

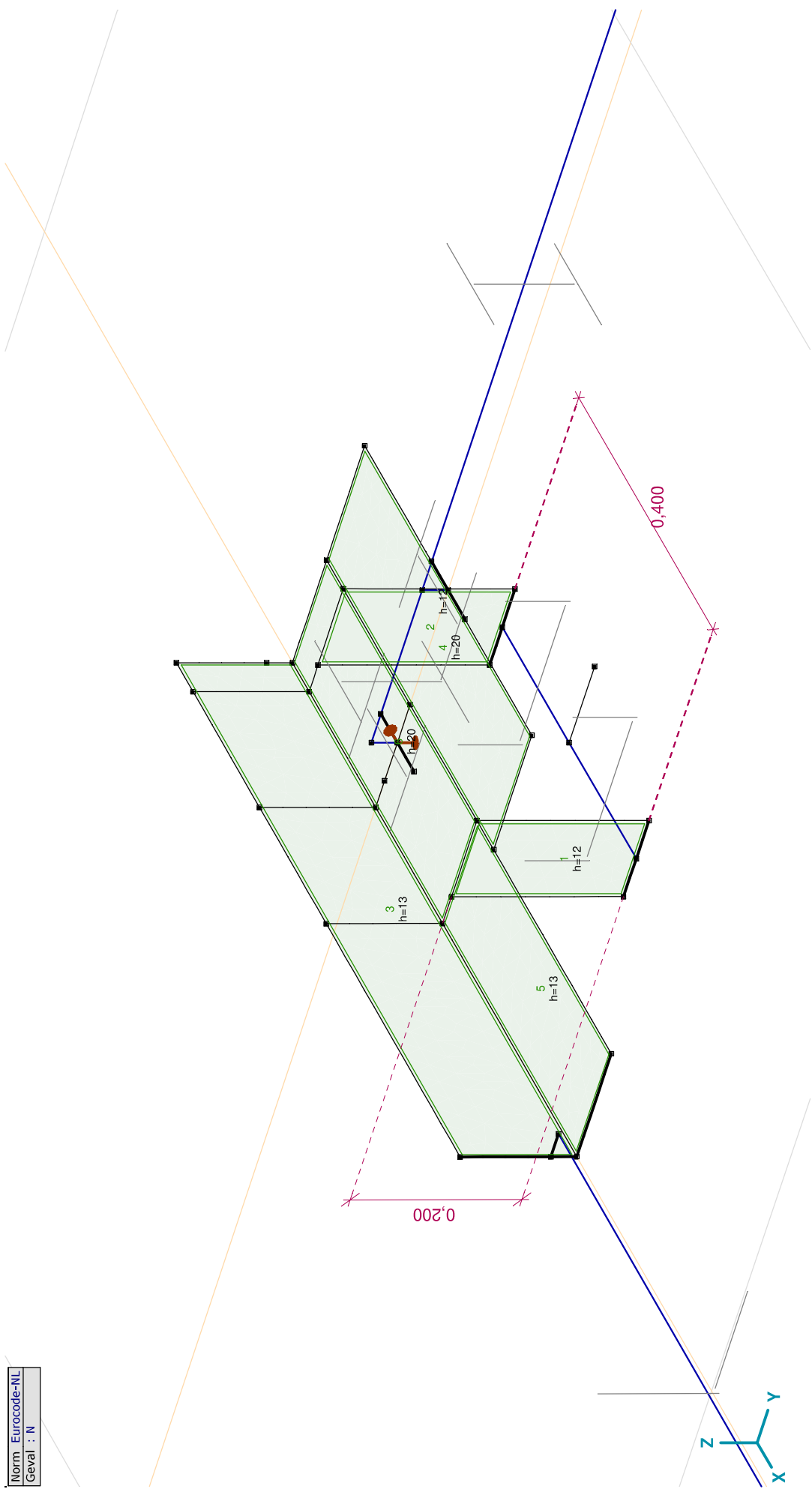

**Project:**





Constructeur: DNV GL - Energy

Model: Post aan onderrand HA\_s.axes

18-5-2021

Pag. 6

## Profielen

	Naam	Tekening	Productie	Vorm	h [mm]	b [mm]	tw [mm]	tf [mm]	r1 [mm]	r2 [mm]	r3 [mm]	Ax [mm <sup>2</sup> ]	Ay [mm <sup>2</sup> ]	Az [mm <sup>2</sup> ]	Ix [mm <sup>4</sup> ]	Iy [mm <sup>4</sup> ]	Iz [mm <sup>4</sup> ]
1	U 200		Gewalst	U	200,0	75,0	8,5	11,5	11,5	6,0	0	3218,52	931,26	1555,63	121078,6	1,9E+07	1477534,0
2	L 150X150X14		Gewalst	L	150,0	150,0	14,0	14,0	16,0	8,0	0	4031,60	1760,18	1776,16	278959,0	84533331,0	8453331,0
3	HE 140 A		Gewalst	I	133,0	140,0	5,5	8,5	12,0	0	0	3142,19	2147,66	704,86	81932,8	1E+07	3893251,0
4	L 140X140X13		Gewalst	L	140,0	140,0	13,0	13,0	15,0	7,5	0	3495,25	1525,43	1539,45	208736,7	6384907,0	6384907,0

	Naam	Iyz [mm <sup>4</sup> ]	I1 [mm <sup>4</sup> ]	I2 [mm <sup>4</sup> ]	α [°]	Iω [mm <sup>6</sup> ]	W1,el,t [mm <sup>3</sup> ]	W1,el,b [mm <sup>3</sup> ]	W2,el,t [mm <sup>3</sup> ]	W2,el,b [mm <sup>3</sup> ]	W1,pl [mm <sup>3</sup> ]	W2,pl [mm <sup>3</sup> ]	iy [mm]	iz [mm]	Hy [mm]	Hx [mm]
1	U 200	0	1,9E+07	1477534,0	0	8,9E+09	191091,8	191091,8	26935,4	73344,2	227755,3	51850,6	77,1	21,4	75,0	200,0
2	L 150X150X14	-4971153,0	1,3E+07	3482178,0	45,00	4,2E+08	126567,2	126567,2	65498,4	58536,3	200109,5	102485,0	45,8	45,8	150,0	150,0
3	HE 140 A	0	1E+07	3893251,0	0	1,5E+10	155382,8	155382,8	55617,9	55617,9	173525,9	84852,6	57,3	35,2	140,0	133,0
4	L 140X140X13	-3754641,0	1E+07	2630265,0	45,00	2,7E+08	102424,9	102424,9	53024,7	47412,5	161917,9	82940,4	42,7	42,7	140,0	140,0

	Naam	yg [mm]	zg [mm]	ys [mm]	zs [mm]	S.p.
1	U 200	20,1	100,0	-38,7	0	8
2	L 150X150X14	42,1	42,1	-33,9	-33,9	4
3	HE 140 A	70,0	66,5	0	0	9
4	L 140X140X13	39,2	39,2	-31,7	-31,7	4

**Naam:** Doorsnede naam; **Productieproces:** Vorm; **Profiel:** h: Doorsnede hoogte; **b:** Doorsnede breedte; **tw:** Lijfdikte; **tf:** Flensdikte; **r1, r2, r3:** Afrondingswaarden; **Ax:** Doorsnede-oppervlak; **Ay, Az:** Afschuivingsoppervlak; **Ix:** Torsieaagheidsmoment; **Iy, Iz:** Buigtraagheidsmoment; **Iyz:** Centrifugaal traagheidsmoment; **I1, I2:** Hoofdbuigtraagheidsmoment; **α:** Hoofdrichtingen; **Iω:** Krommingsconstante; **W1,el,t, W2,el,t, W1,pl, W2,pl:** Traagheidsstraal; **W1,el,b, W2,el,b:** Plasticiteit modulus; **iy, iz:** Traagheidsstraal; **Hy, Hx:** Afmeting in lokale Y-richting; **Hx:** Afmeting in lokale Z-richting; **yg:** Y-coördinaat van het zwaartepunt; **zg:** Z-coördinaat van het zwaartepunt; **ys:** Y-coördinaat van het afschuivingsmiddelpunt (torsie); **zs:** Z-coördinaat van het afschuivingsmiddelpunt (torsie); **S.p.:** Spanningspunten;

**Project:**

Constructeur: DNV GL - Energy

Model: Post aan onderrand HA\_s\_axs

18-5-2021

Pag. 7

## Domeinen

Element type	Materiaal	Ref <sub>x</sub>	Ref <sub>z</sub>	Dikte [mm]	k, buiging [l]	k, torsie [l]	k, afschuiving [l]	Oppervlakte [m <sup>2</sup> ]	Gat	Mesh
1 # Schaal	S 355	Auto	Auto	12				0,020	-	✓
2 # Schaal	S 355	Auto	Auto	12				0,020	-	✓
3 # Schaal	S 355	Auto	Auto	13				0,115	-	✓
4 # Schaal	S 355	Auto	Auto	20				0,075	-	✓
5 # Schaal	S 355	Auto	Auto	13				0,054	-	✓
6 # Schaal	S 355	Auto	Auto	20				0,061	-	✓

**Element type:** Plaatlement type; **Ref<sub>x</sub>:** Referentie voor lokale X-richting; **Ref<sub>z</sub>:** Referentie voor lokale Z-richting; **k, buiging:** Buigsterkte coefficient; **k, torsie:** Torsiesterkte coefficient; **k, afschuiving:** Dwarskrachtsterkte coefficient; **Oppervlakte:** Domein oppervlak; **Gat:** Aantal gaten in domein; **Mesh:** Gegeneerde mesh;

## Knooppopleggingen

Knoop	X [m]	Y [m]	Z [m]
1	32	1,600	0,030
2	45	0	1,285
3	10	0	0,085

Knoop	Type	Naam <sub>x</sub>	K <sub>x</sub> [kN/m]	K <sub>x,y</sub> [kN/m]	Naam <sub>y</sub>	K <sub>y</sub> [kN/m]	K <sub>y,v</sub> [kN/m]	Naam <sub>z</sub>	K <sub>z</sub> [kN/m]	K <sub>z,v</sub> [kN/m]	Naam <sub>xx</sub>	K <sub>xx</sub> [kNm/rad]	K <sub>xx,v</sub> [kNm/rad]	Naam <sub>yy</sub>
1	32	Glob.	—	—	Vast - translatie	1E+10	1E+10	Vast - translatie	1E+10	1E+10	Vast - rotatie	1E+10	1E+10	—
2	45	Glob.	Vast - translatie	1E+10	Vast - translatie	1E+10	1E+10	Vast - translatie	1E+10	1E+10	—	—	—	Vast - rotatie
3	10	Glob.	Vast - translatie	1E+10	—	—	—	Vast - translatie	1E+10	1E+10	—	—	—	—

Knoop	K <sub>yy</sub> [kNm/rad]	K <sub>yy,v</sub> [kNm/rad]	Naam <sub>zz</sub>	K <sub>zz</sub> [kNm/rad]	K <sub>z,v</sub> [kNm/rad]
1	32	—	—	—	—
2	45	1E+10	—	—	—
3	10	—	—	—	—

**Knoop:** Ondersteunde knoop; **Type:** Opleggingstype; **Naam<sub>x</sub>:** Naam van de veereigenschappen; **K<sub>x</sub>:** Initiele stijfheid; **K<sub>y</sub>:** Trillingsstijfheid; **Naam<sub>y</sub>:** Naam van de veereigenschappen; **K<sub>y</sub>:** Trillingsstijfheid; **Naam<sub>z</sub>:** Naam van de veereigenschappen; **K<sub>z</sub>:** Trillingsstijfheid; **Naam<sub>xx</sub>:** Naam van de veereigenschappen; **K<sub>xx</sub>:** Initiele stijfheid; **K<sub>xx,v</sub>:** Trillingsstijfheid; **Naam<sub>yy</sub>:** Naam van de veereigenschappen; **K<sub>yy</sub>:** Trillingsstijfheid; **Naam<sub>zz</sub>:** Naam van de veereigenschappen; **K<sub>zz</sub>:** Trillingsstijfheid; **K<sub>z,v</sub>:** Trillingsstijfheid;



**Project:**

Constructeur: DNV GL - Energy

Model: **Post aan onderrand HA\_s.axes**

18-5-2021

Pag. 8

**Mx: Knoopbelastingen**

	<i>Richting</i>	<i>F<sub>x</sub></i> [kN]	<i>F<sub>y</sub></i> [kN]	<i>F<sub>z</sub></i> [kN]	<i>M<sub>x</sub></i> [kNm]	<i>M<sub>y</sub></i> [kNm]	<i>M<sub>z</sub></i> [kNm]
28	Global	0	2,50	0	5,70	0	0

**F<sub>x</sub>, F<sub>y</sub>, F<sub>z</sub>:** Belastingkracht component; **M<sub>x</sub>, M<sub>y</sub>, M<sub>z</sub>:** Belastingmoment component;

**Project:**

Constructeur: DNV GL - Energy

Model: Post aan onderrand HA\_s.axs

Norm	Eurocode-NL
Geval	Mx

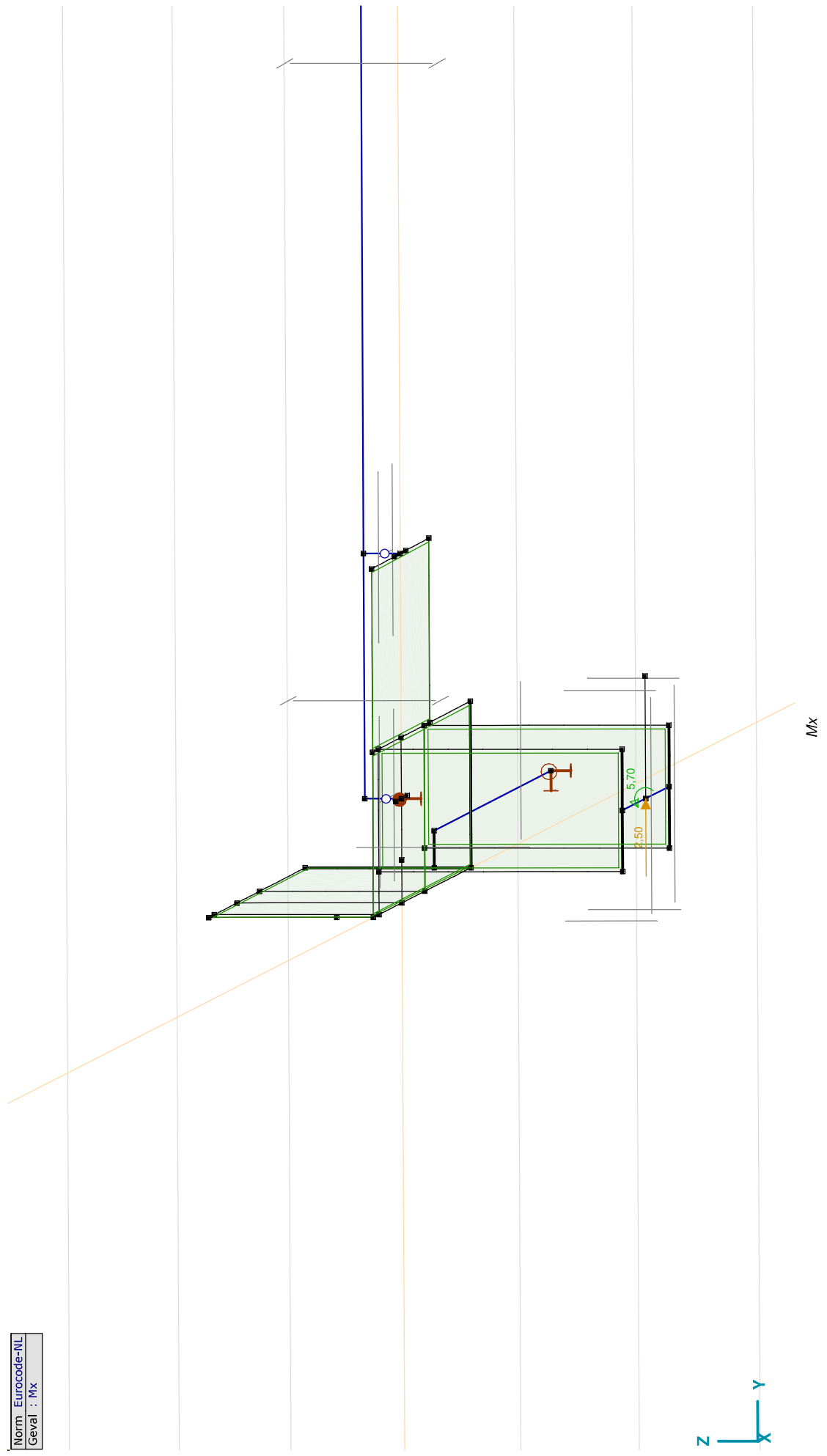

**Project:**

Constructeur: DNV GL - Energy

Model: **Post aan onderrand HA\_s.axes**

**My: Knoopbelastingen**

	<i>Richting</i>	$F_x$ [kN]	$F_y$ [kN]	$F_z$ [kN]	$M_x$ [kNm]	$M_y$ [kNm]	$M_z$ [kNm]
28	Global	4,40	0	0	0	13,90	0

**Fx, Fy, Fz:** Belastingkracht component; **Mx, My, Mz:** Belastingmoment component;

**Project:**

Constructeur: DNV GL - Energy  
Model: Post aan onderwand HA\_s.axs

Norm: Eurocode-NL  
Geval: My

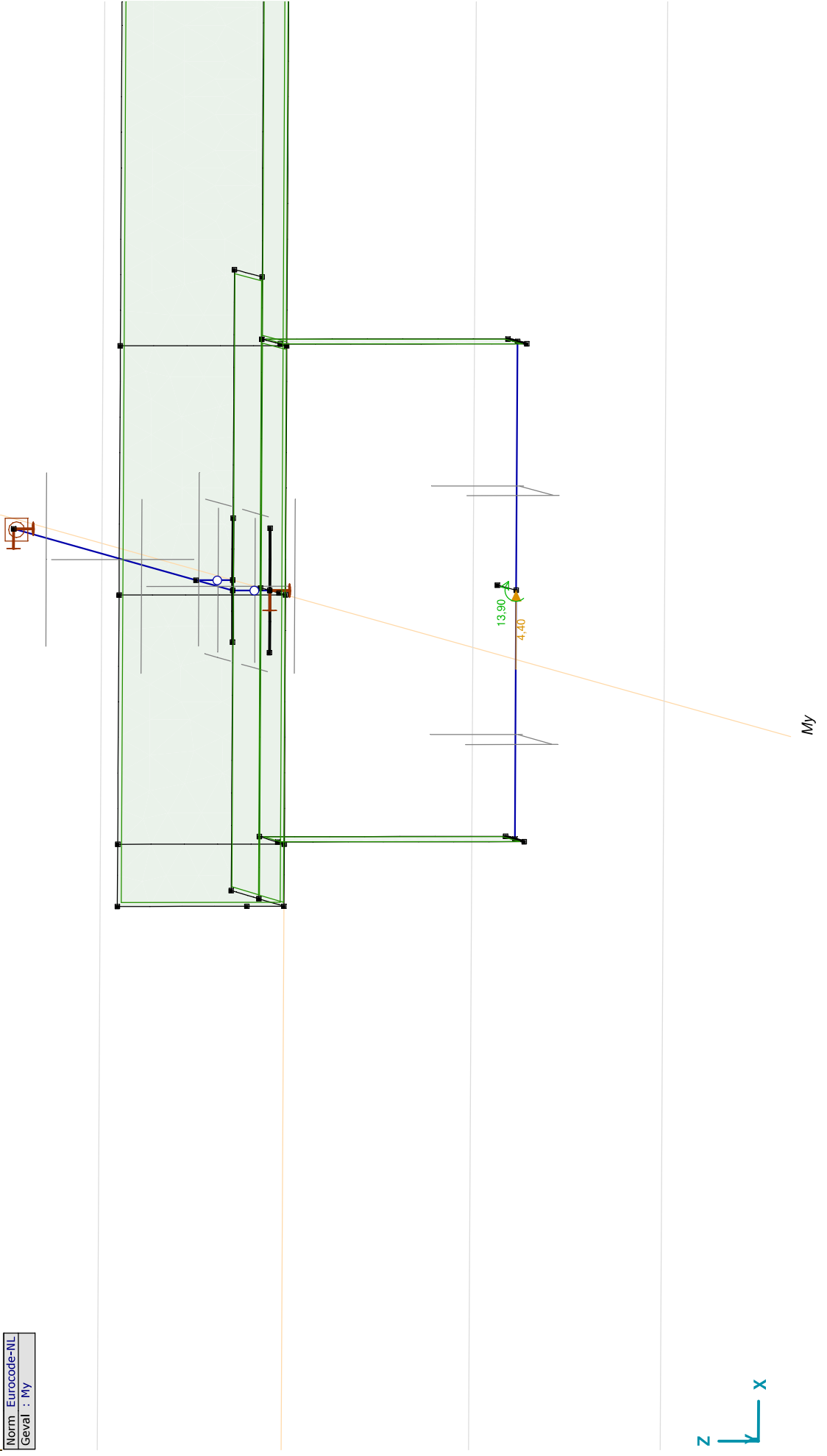

**Project:**

Constructeur: DNV GL - Energy

Model: **Post aan onderrand HA\_s.axes****Fz: Knoopbelastingen**

	<i>Richting</i>	<i>F<sub>x</sub></i> [kN]	<i>F<sub>y</sub></i> [kN]	<i>F<sub>z</sub></i> [kN]	<i>M<sub>x</sub></i> [kNm]	<i>M<sub>y</sub></i> [kNm]	<i>M<sub>z</sub></i> [kNm]
28	Global	0	0	-3,50	0	0	0

**F<sub>x</sub>, F<sub>y</sub>, F<sub>z</sub>:** Belastingkracht component; **M<sub>x</sub>, M<sub>y</sub>, M<sub>z</sub>:** Belastingmoment component;

**Project:**

Constructeur: DNV GL - Energy  
Model: Post aan onderand HA\_s.axes

Norm: Eurocode-NL  
Geval: Fz

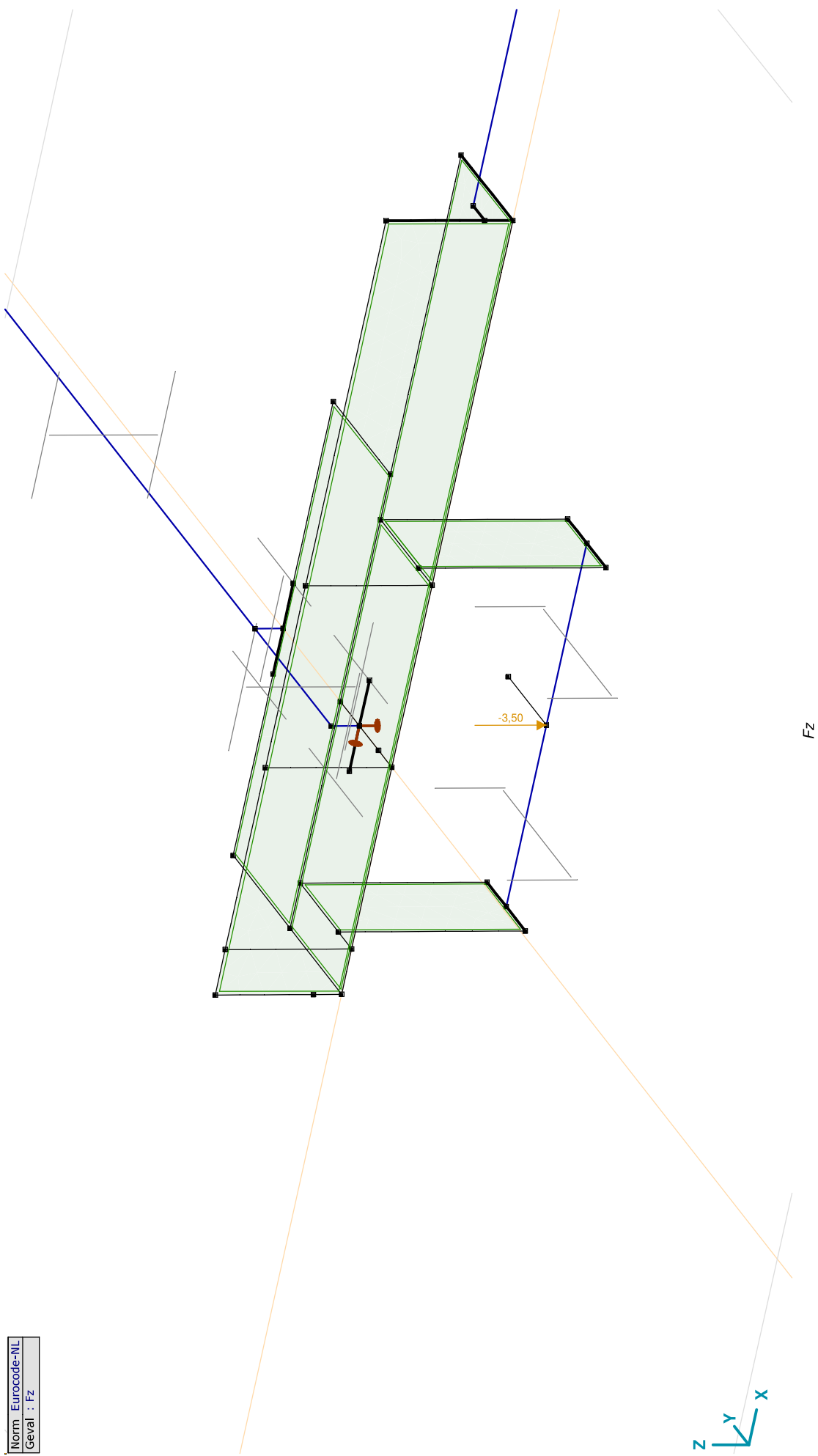

**Project:**

Constructeur: DNV GL - Energy

Model: **Post aan onderrand HA\_s.axes**

N: Knoopbelastingen

	<i>Richting</i>	$F_x$ [kN]	$F_y$ [kN]	$F_z$ [kN]	$M_x$ [kNm]	$M_y$ [kNm]	$M_z$ [kNm]
32	Globaal	-30,00	0	0	0	0	0

**Fx, Fy, Fz:** Belastingkracht component; **Mx, My, Mz:** Belastingmoment component;

**Project:**

Constructeur: DNV GL - Energy

Model: Post aan onderrand HA\_s.axs

Norm	Eurocode-NL
Geval	: N

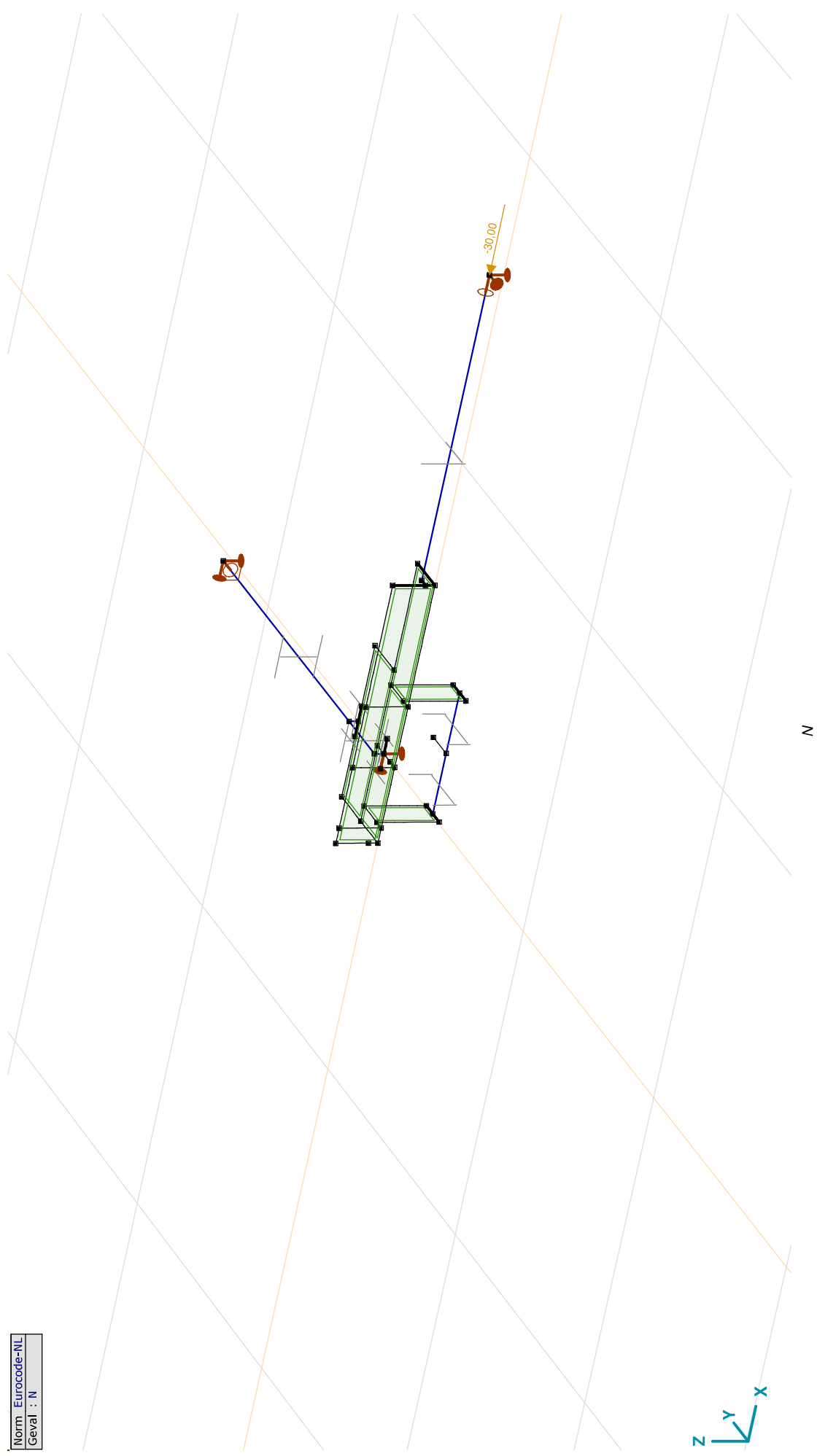



**Project:**

Constructeur: DNV GL - Energy

Model: Post aan onderrand HA\_s.axes

## Gebruiker gedefinieerde belastingcombinaties uit belastinggevallen

	<i>Naam</i>	<i>Type</i>	<i>Mx</i>	<i>My</i>	<i>Fz</i>	<i>N</i>	<i>Commentaar</i>
1	Co #1	UGT	1,00	0	1,00	1,00	
2	Co #2	UGT	0	1,00	1,00	1,00	
3	Co #3	UGT	-1,00	0	1,00	1,00	
4	Co #4	UGT	0	-1,00	1,00	1,00	
5	Co #5	UGT	0,71	0,71	1,00	1,00	
6	Co #6	UGT	-0,71	-0,71	1,00	1,00	

Naam: Naam belastingcombinatie; **T**ype: Type belastingcombinatie; **Mx, My, Fz, N**: Factor;

**Project:**

Constructeur: DNV GL - Energy

Model: Post aan onderrand HA\_s.axes

18-5-2021

Pag. 17

Lineaire berekening	
Norm	Eurocode-NL
Geval	: Omhullende Min, Max
Omhullende	: Alle UGT
E (P)	: 9,99E-10
E (W)	: 9,99E-10
E (Eq)	: 2,18E-8
Comp.	: Nx [kN]

	Nx [kN]
	30,2
	25,9
	21,6
	17,2
	12,9
	8,6
	4,2
	-0,1
	-4,4
	-8,8
	-13,1
	-17,4
	-21,8
	-26,1
	-30,4

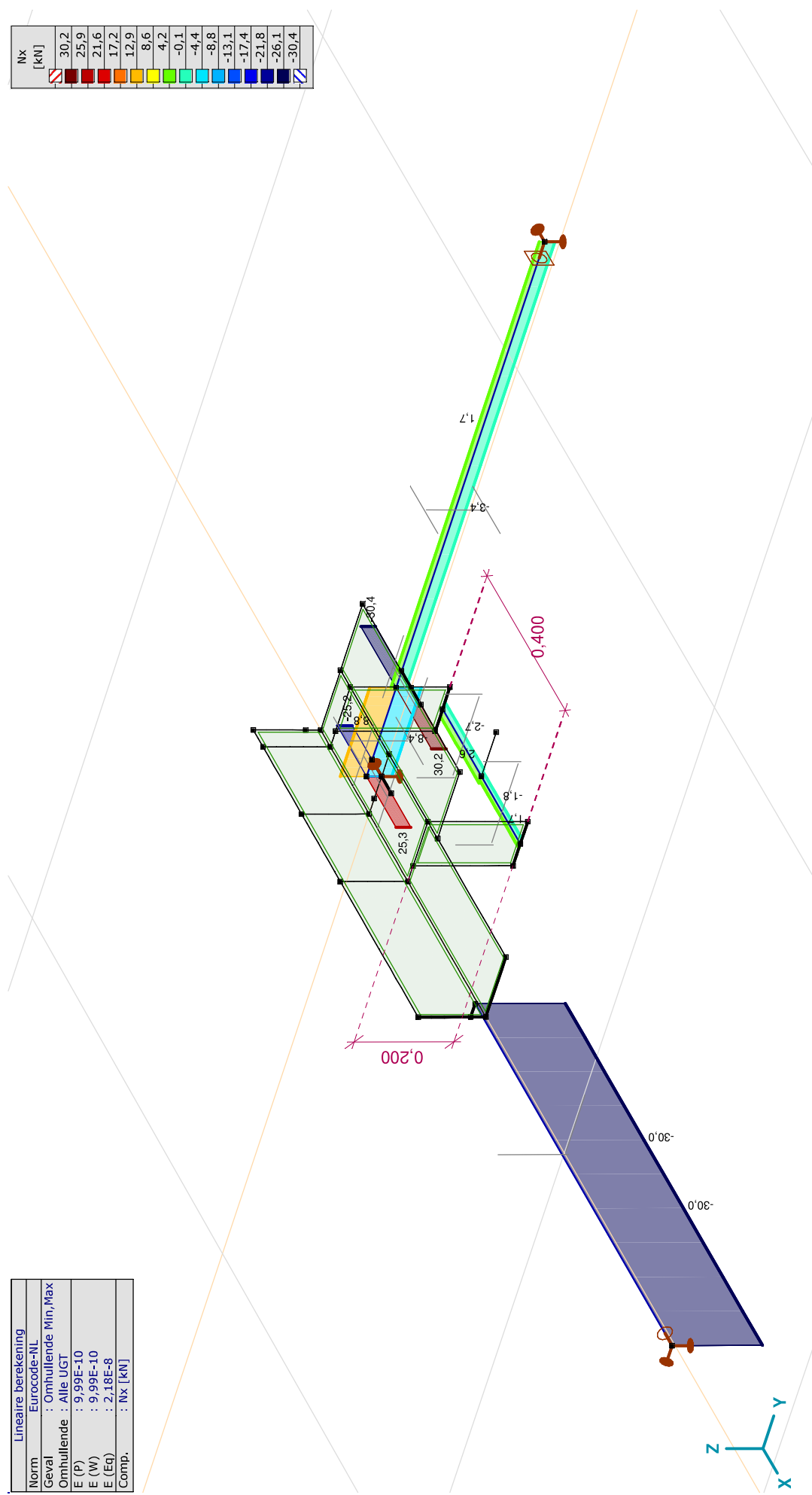

[[], Lineair, Omhullende (Alle UGT), Nx, Lijnen (gevuld)]

**Project:**

Constructeur: DNV GL - Energy

Model: Post aan onderrand HA\_s.axes

Lineaire berekening	
Norm	: Eurocode-NL
Geval	: Omhullende Min,Max
Omhullende	: Alle UGT
E (P)	: 9.99E-10
E (W)	: 9.99E-10
E (Eq)	: 2.18E-8
Comp.	: My [kNm]

My [kNm]
8.7
7.5
6.4
5.2
4.1
2.9
1.7
0.6
-0.6
-1.8
-2.9
-4.1
-5.2
-6.4
-7.6

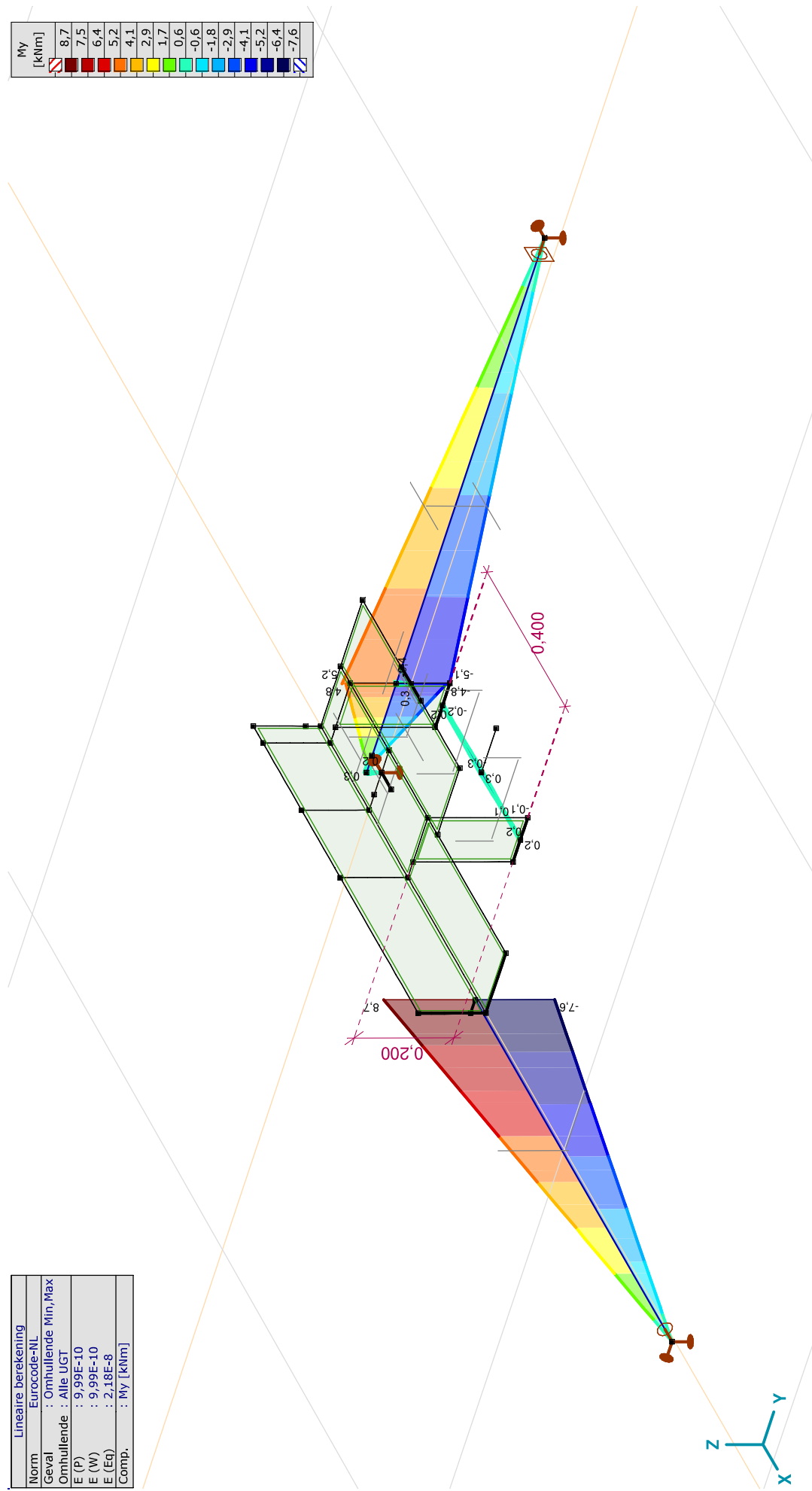

[[], Lineair, Omhullende (Alle UGT), My, Lijnen (gevuld)

**Project:**

Constructeur: DNV GL - Energy

Model: Post aan onderrand HA\_s.axes

Lineaire berekening	
Norm	: Eurocode-NL
Geval	: Omhullende Min,Max
Omhullende	: Alle UGT
E (P)	: 9.99E-10
E (W)	: 9.99E-10
E (Eq)	: 2.18E-8
Comp.	: Mz [kNm]

Mz [kNm]	7.3
	6.3
	5.3
	4.3
	3.3
	2.3
	1.3
	0.4
	-0.6
	-1.6
	-2.6
	-3.6
	-4.6
	-5.6
	-6.6

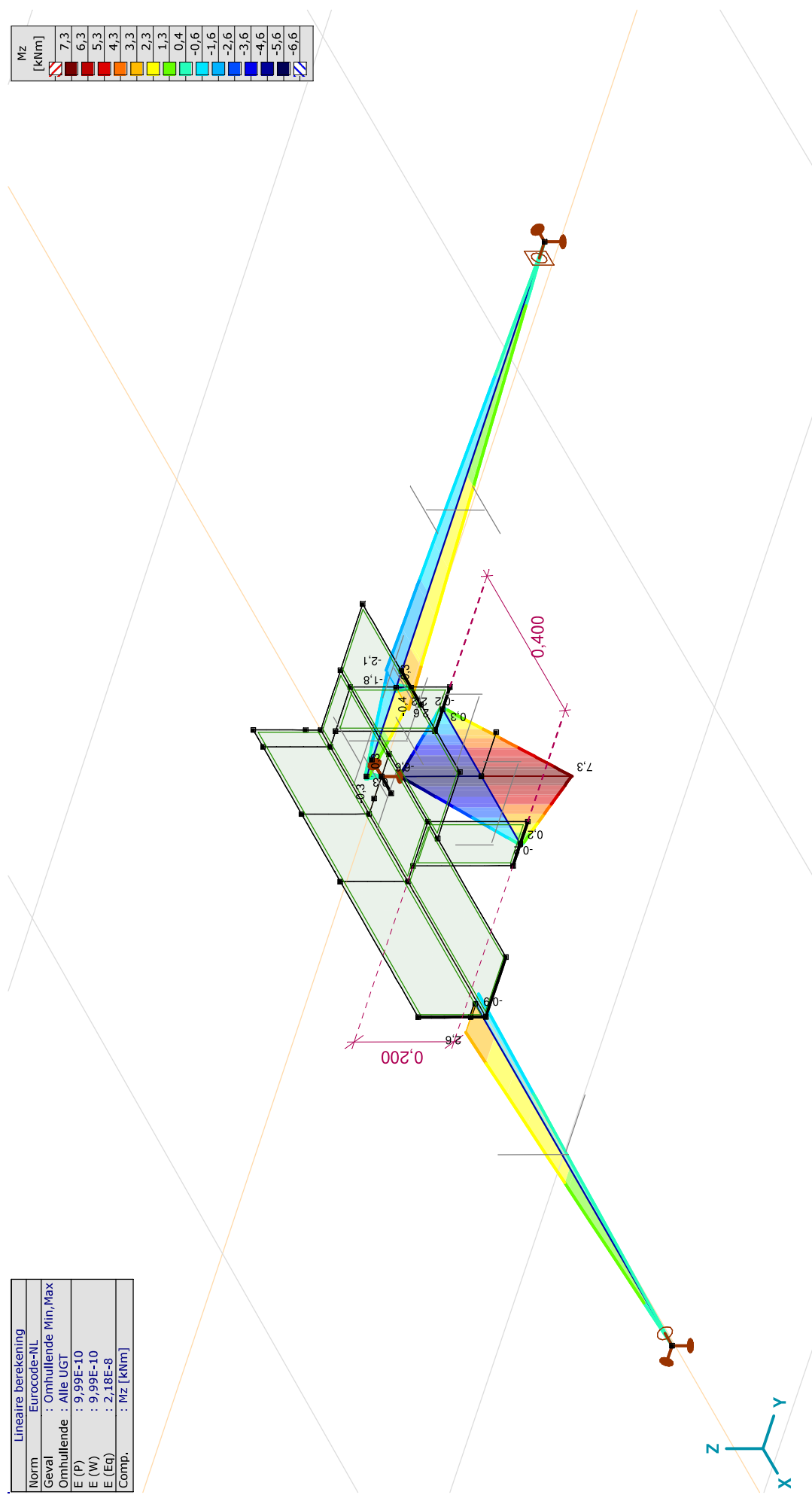

[[J], Lineair, Omhullende (Alle UGT), Mz, Lijnen (gevuld)]

**Project:**

Constructeur: DNV GL - Energy  
 Model: Post aan onderrand HA\_s.axes

Lineaire berekening	
Norm	Eurocode-NL
Geval	: Omhullende Min,Max
Omhullende	: Alle UGT
E (P)	: 9,99E-10
E (W)	: 9,99E-10
E (Eq)	: 2,18E-8
Comp.	: Vz [kN]

Vz [kN]
25,3
21,7
18,1
14,5
10,9
7,3
3,7
0,1
-3,5
-7,1
-10,7
-14,4
-18,0
-21,6
-25,2

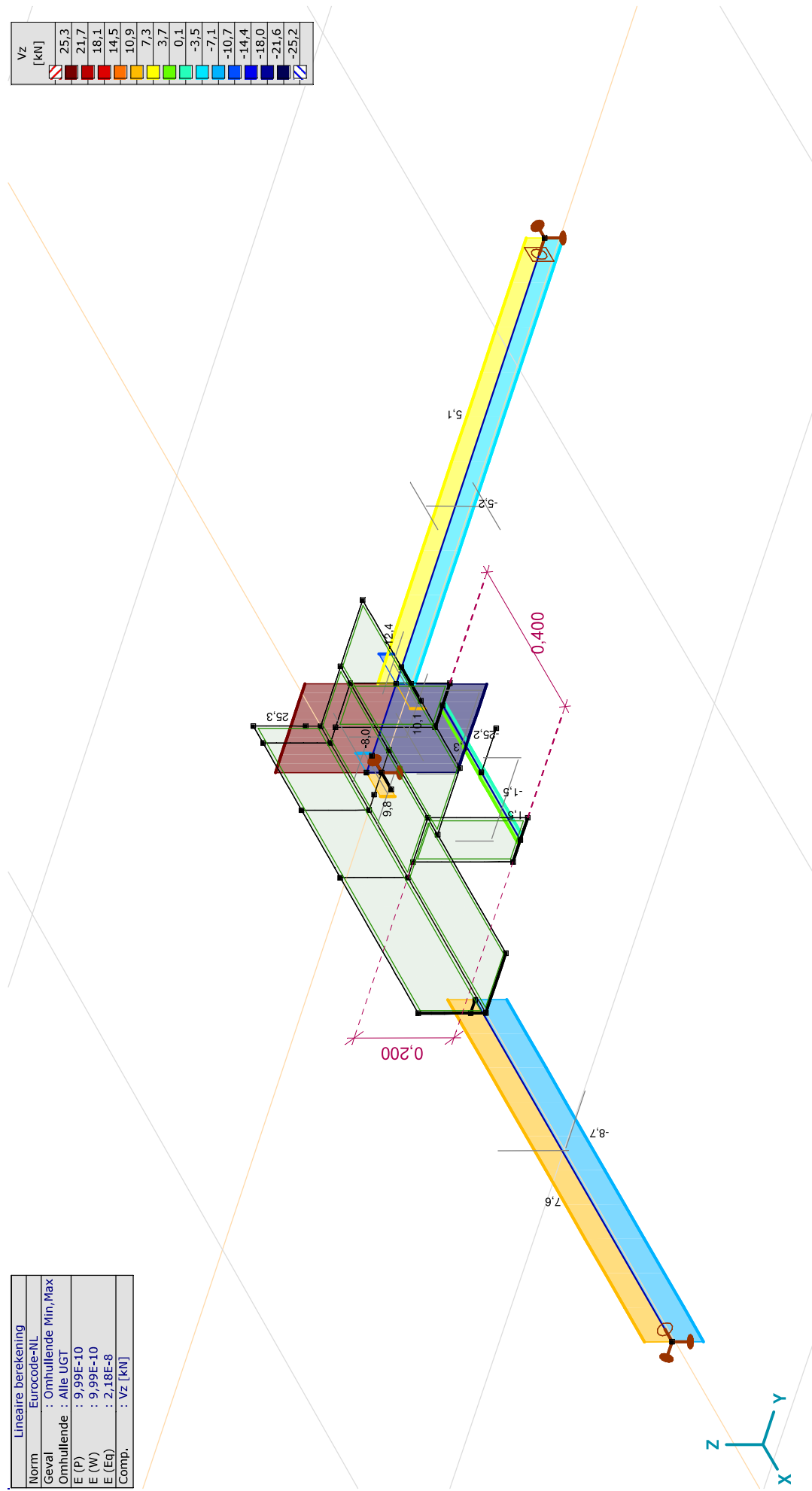

[I], Lineair, Omhullende (Alle UGT), Vz, Lijnen (gevuld)

**Project:**

Constructeur: DNV GL - Energy

Model: Post aan onderrand HA\_s.axes

18-5-2021

Pag. 21

Lineaire berekening	
Norm	Eurocode-NL
Geval	: Omhullende Min,Max
Omhullende	: Alle UGT
E (P)	: 9.99E-10
E (W)	: 9.99E-10
E (Eq)	: 2.18E-8
Comp.	: Vy [kN]

Vy [kN]	
35,4	
30,4	
25,3	
20,2	
15,2	
10,1	
5,1	
0	
-5,1	
-10,1	
-15,2	
-20,2	
-25,3	
-30,4	
-35,4	

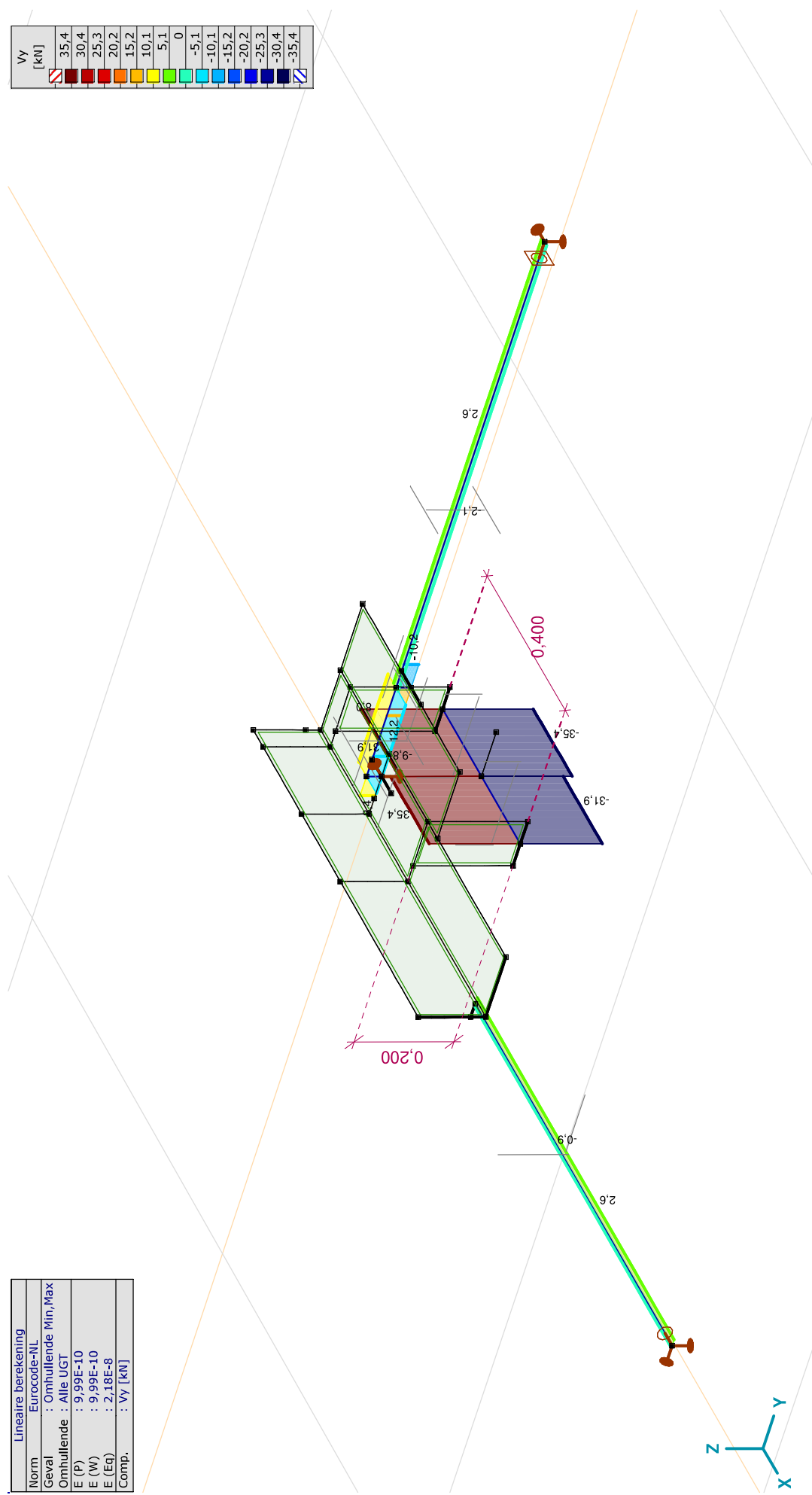

[I], Lineair, Omhullende (Alle UGT), Vy, Lijnen (gevuld)

**Project:**

Constructeur: DNV GL - Energy  
 Model: Post aan onderrand HA\_s.axes

Lineaire berekening	
Norm	: Eurocode-NL
Geval	: Omhullende Min,Max
Omhullende	: Alle UGT
E (P)	: 9.99E-10
E (W)	: 9.99E-10
E (Eq)	: 2.18E-8
Comp.	: Tx [kNm]

Tx [kNm]
2.8
2.4
2.0
1.6
1.2
0.8
0.4
0
-0.4
-0.8
-1.2
-1.6
-2.0
-2.4
-2.9

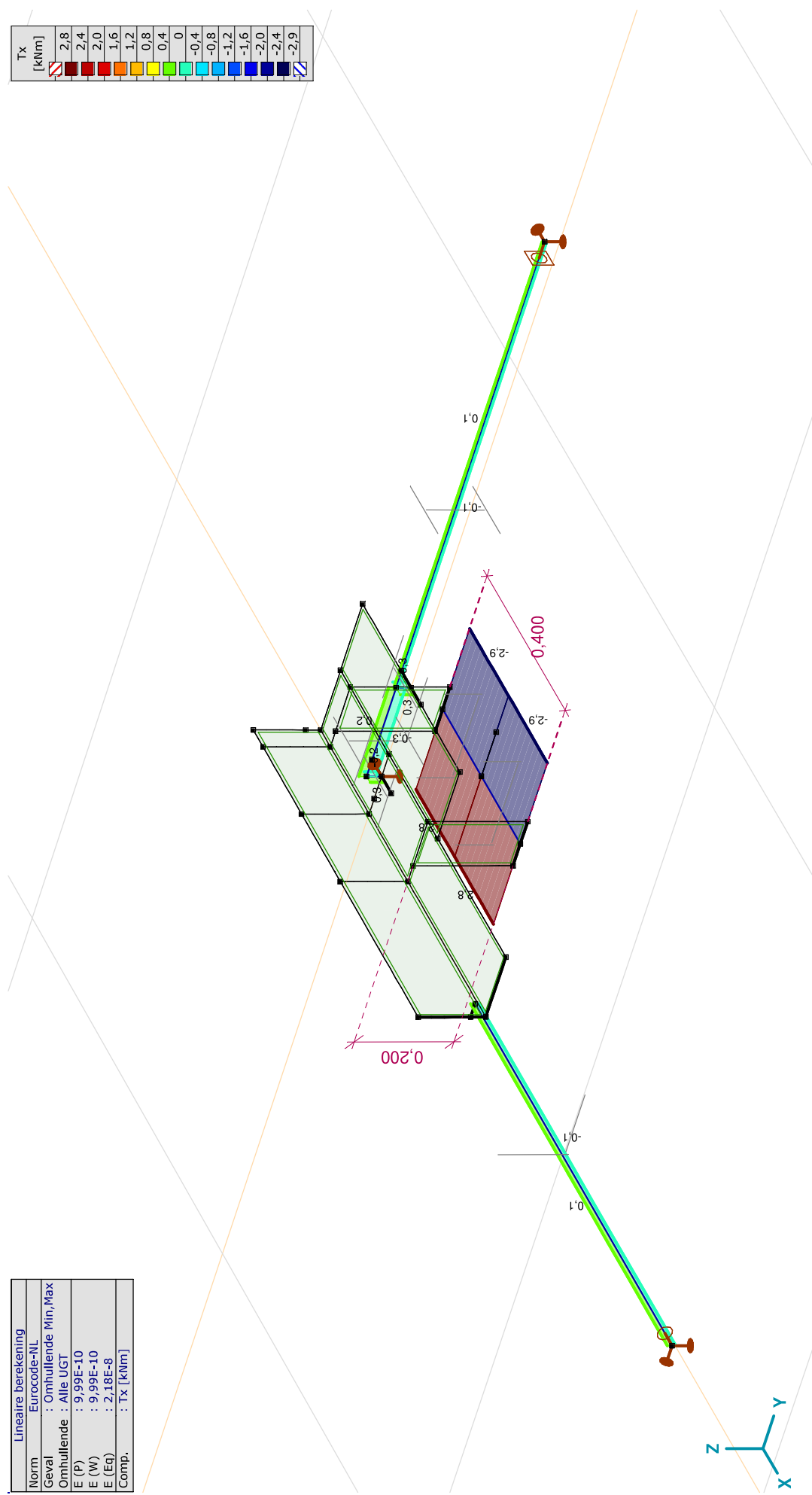

[I], Lineair, Omhullende (Alle UGT), Tx, Lijnen (gevuld)

**Project:**

Constructeur: DNV GL - Energy

Model: Post aan onderrand HA\_s.axes

Lineaire berekening
Norm Eurocode-NL
Geval : Co #1
E (P) : 9,99E-10
E (W) : 9,99E-10
E (Eq) : 2,18E-8
Comp. : eR [mm]

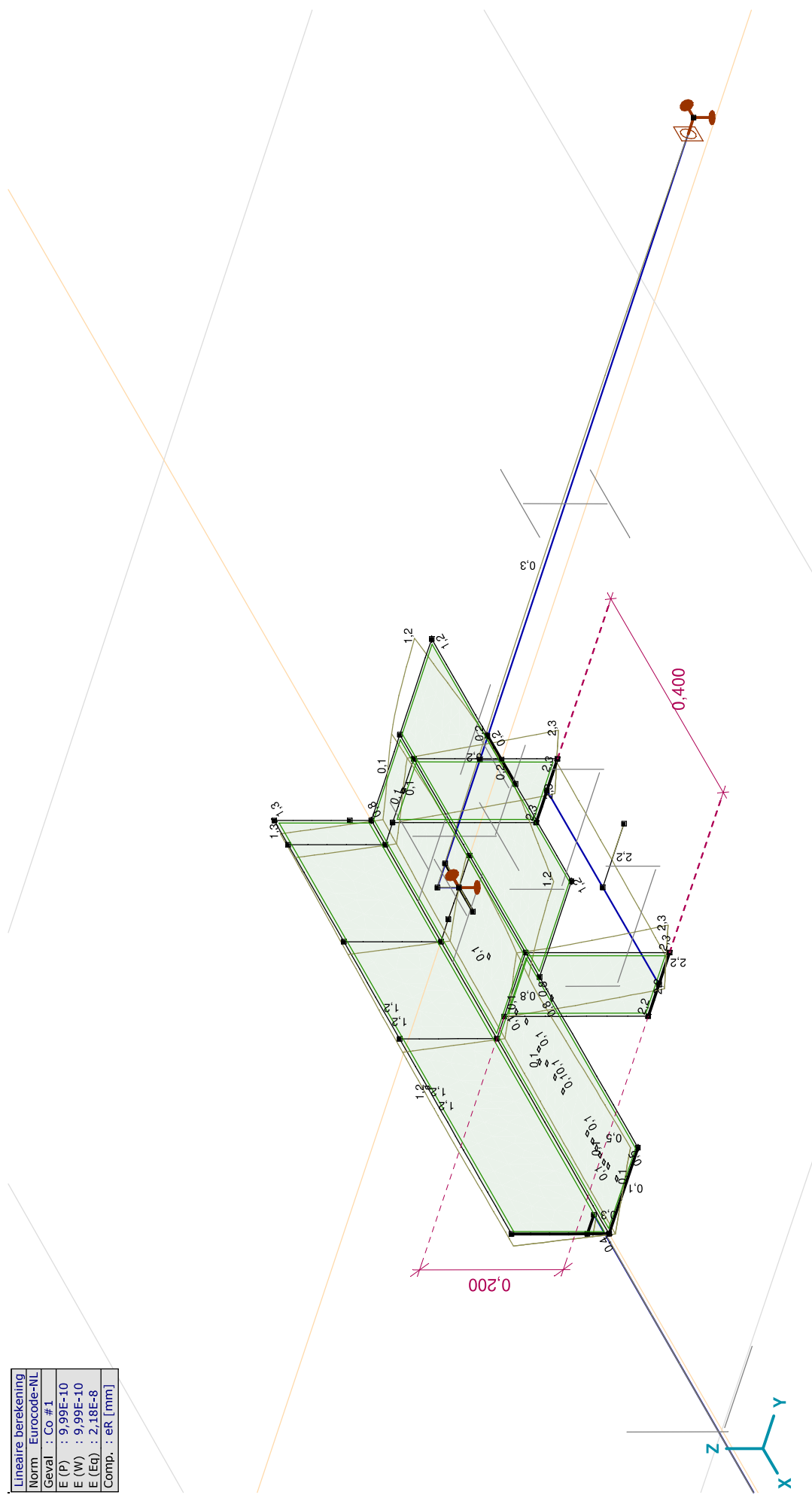

[1], Linear, Co #1 (UGT), eR, Lijnen





**Project:**

Constructeur: DNV GL - Energy

Model: Post aan onderrand HA\_s.axes

18-5-2021

Pag. 25

Lineaire berekening
Norm Eurocode-NL
Geval : Co #3
E (P) : 9,99E-10
E (W) : 9,99E-10
E (Eq) : 2,18E-8
Comp. : eR [mm]

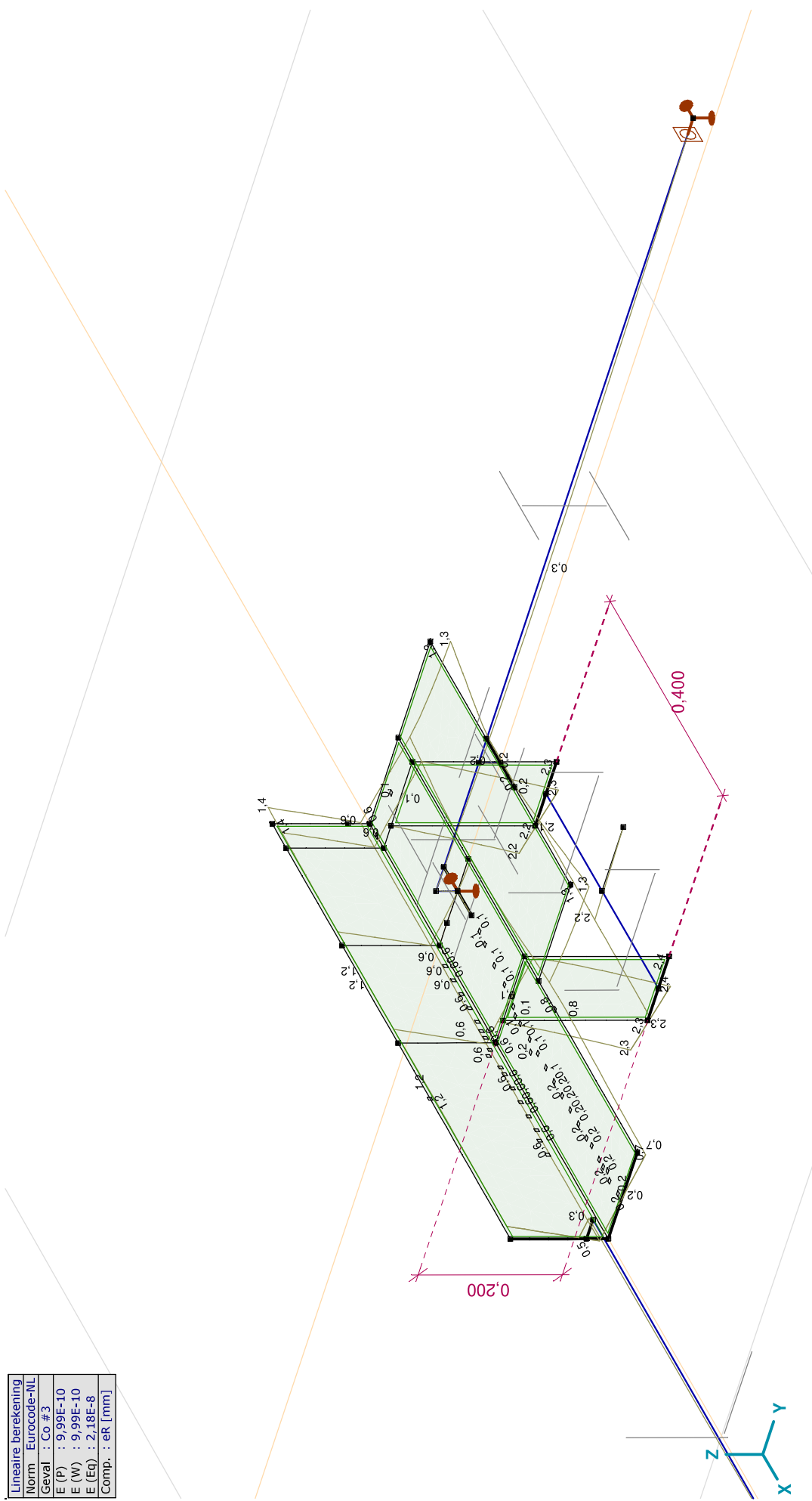

[1], Lineair, Co #3 (UGT), eR, Lijnen







**Project:**

Constructeur: DNV GL - Energy  
 Model: Post aan onderrand HA\_s.axs

Lineaire berekening
Norm Eurocode-NL
Geval : Co #1
E (P) : 9,99E-10
E (W) : 9,99E-10
E (Eq) : 2,18E-8
Comp. : SVM T [N/mm <sup>2</sup> ]

SVM T [N/mm <sup>2</sup> ]
355,0
329,8
304,6
279,4
254,3
229,1
203,9
178,7
153,5
128,3
103,2
78,0
52,8
27,6
2,4

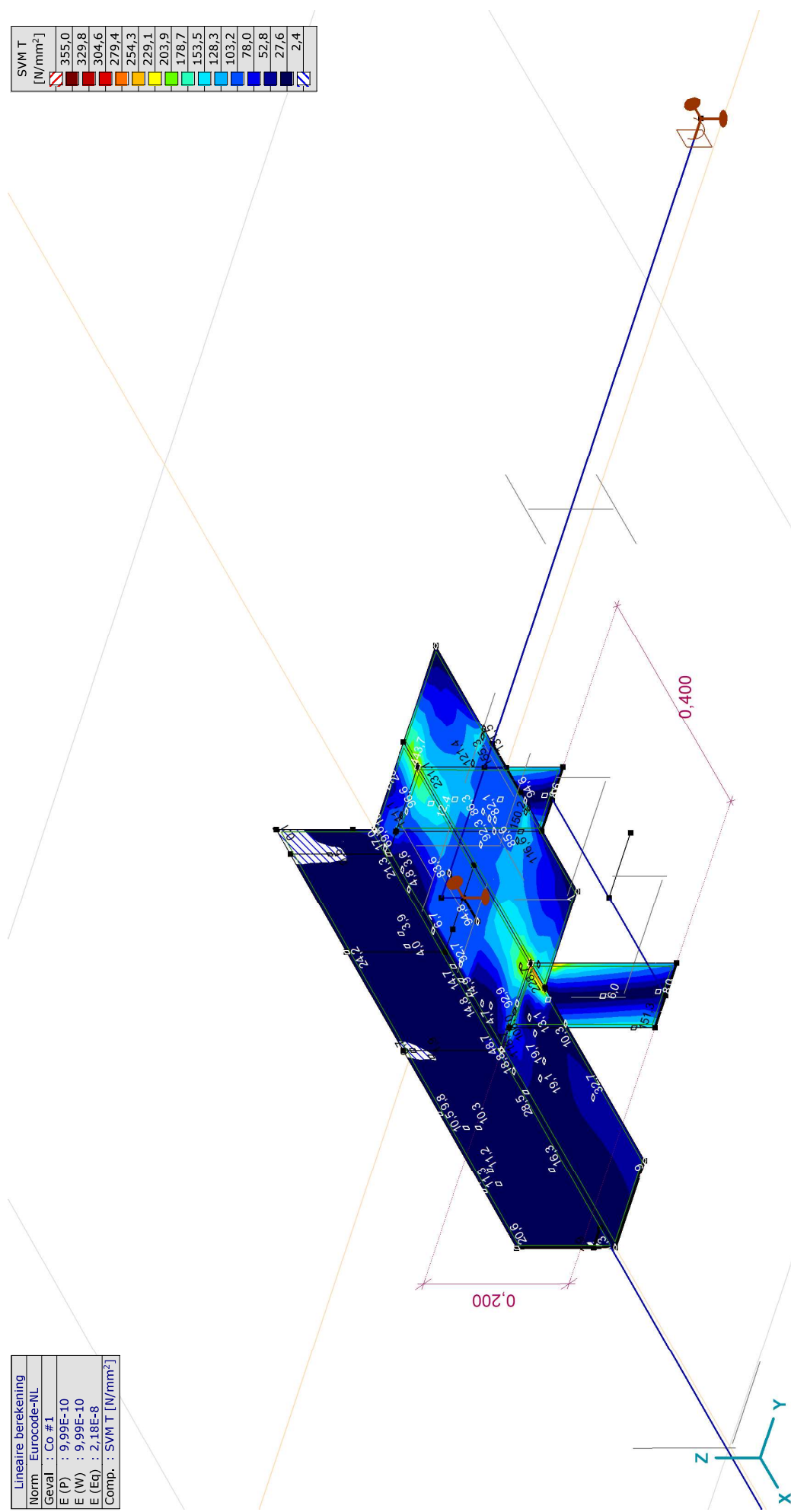

[[J], Lineair, Co #1 (UGT), SVM T, Kleuren 2D



**Project:**

Constructeur: DNV GL - Energy  
 Model: Post aan onderrand HA\_s.axes

Lineaire berekening
Norm Eurocode-NL
Geval : Co #3
E (P) : 9,99E-10
E (W) : 9,99E-10
E (Eq) : 2,18E-8
Comp. : SVM T [N/mm <sup>2</sup> ]

SVM T [N/mm <sup>2</sup> ]
355,0
329,8
304,6
279,4
254,3
229,1
203,9
178,7
153,5
128,3
103,2
78,0
52,8
27,6
2,4

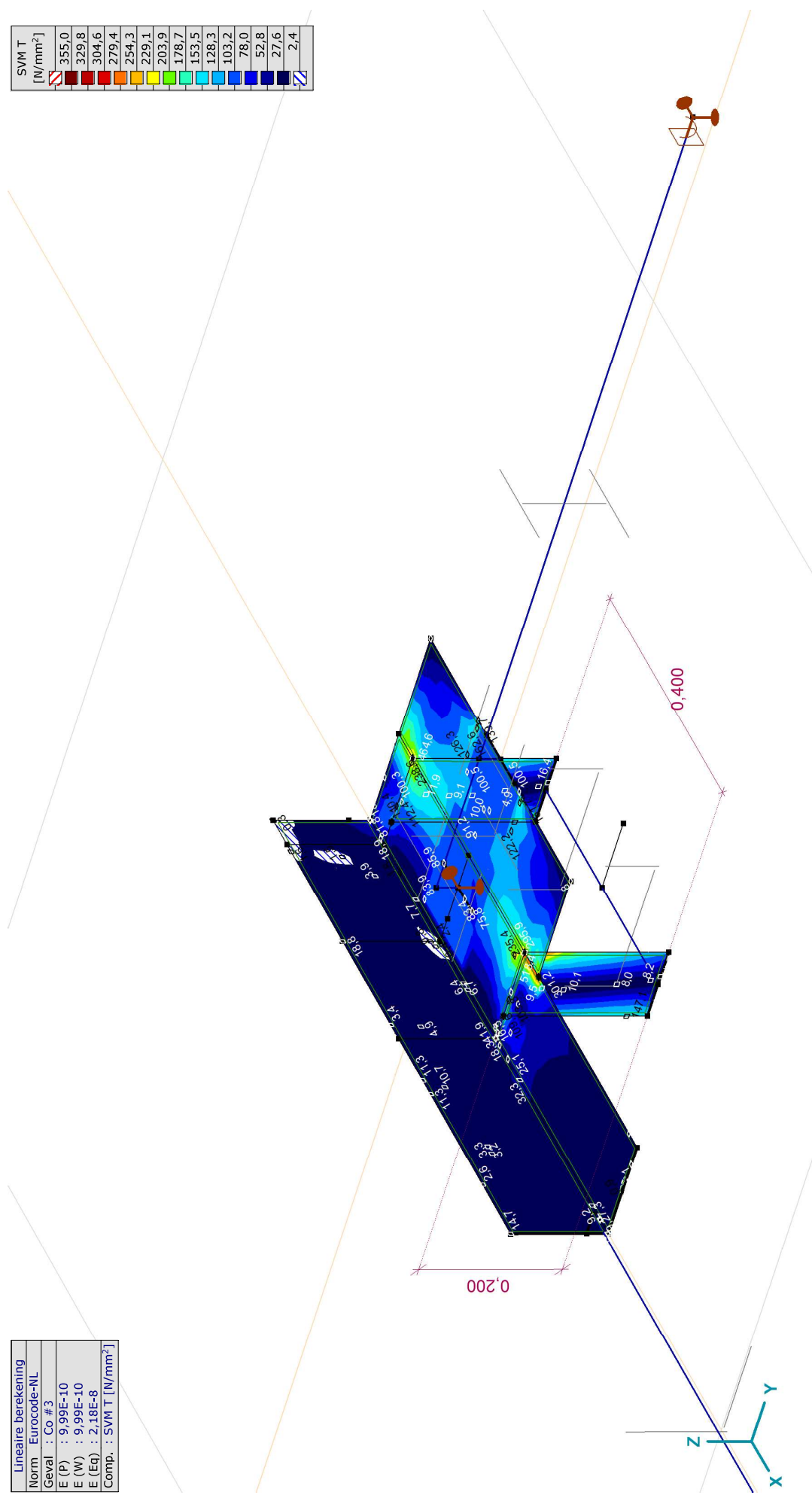

[J], Lineair, Co #3 (UGT), SVM T, Kleuren 2D



**Project:**

Constructeur: DNV GL - Energy

Model: Post aan onderrand HA\_s.axs

18-5-2021

Pag. 32

Lineaire berekening
Norm Eurocode-NL
Geval : Co #4
E (P) : 9,99E-10
E (W) : 9,99E-10
E (Eq.) : 2,18E-8
Comp. : SVM T [N/mm <sup>2</sup> ]

SVM T [N/mm <sup>2</sup> ]
355,0
329,8
304,6
279,4
254,3
229,1
203,9
178,7
153,5
128,3
103,2
78,0
52,8
27,6
2,4

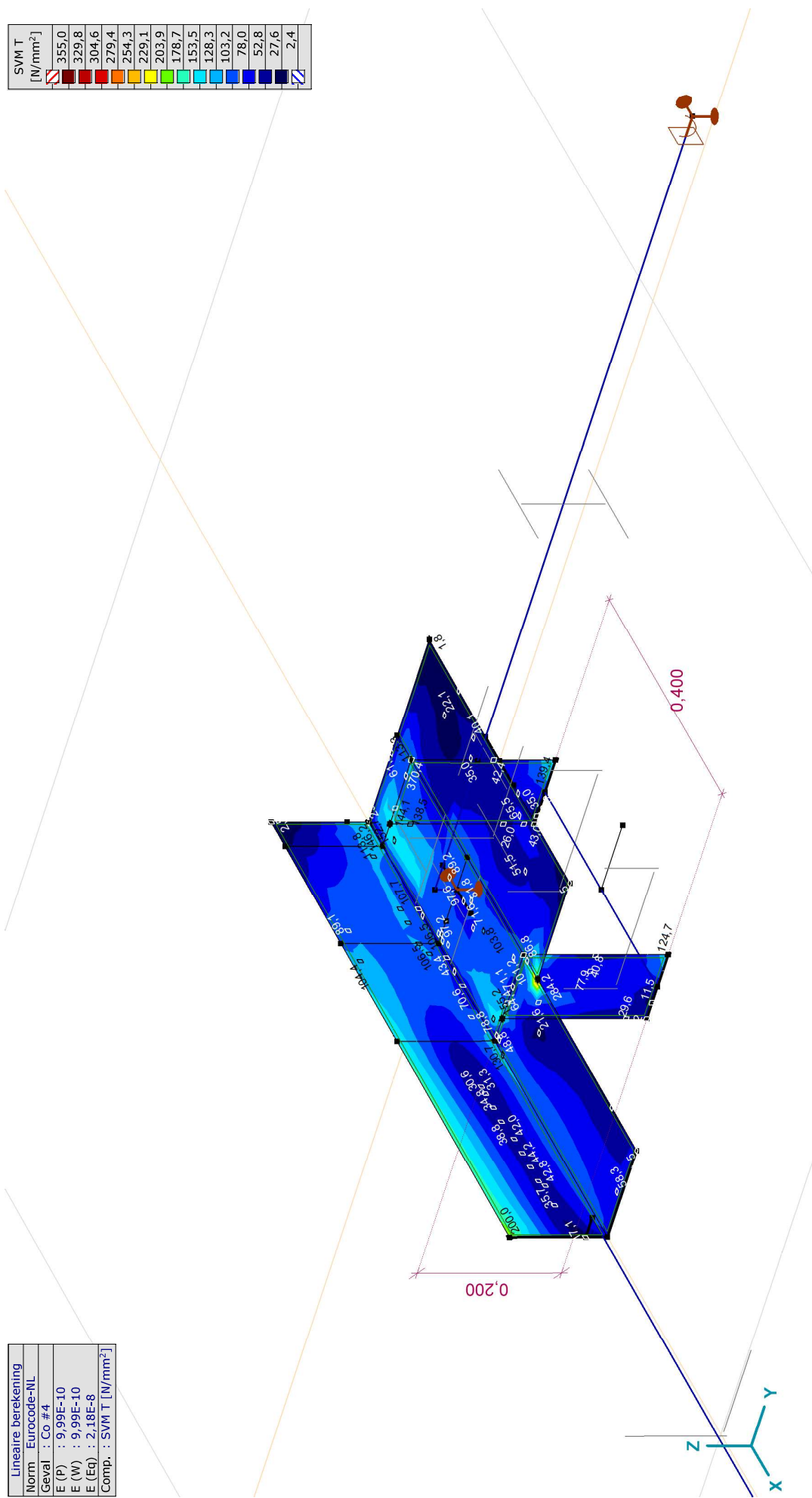

[J], Lineair, Co #4 (UGT), SVM T, Kleuren 2D

**Project:**

Constructeur: DNV GL - Energy  
 Model: Post aan onderrand HA\_s.axes

Lineaire berekening
Norm Eurocode-NL
Geval : Co #5
E (P) : 9,99E-10
E (W) : 9,99E-10
E (Eq) : 2,18E-8
Comp. : SVM T [N/mm <sup>2</sup> ]

SVM T [N/mm <sup>2</sup> ]
355,0
329,8
304,6
279,4
254,3
229,1
203,9
178,7
153,5
128,3
103,2
78,0
52,8
27,6
2,4

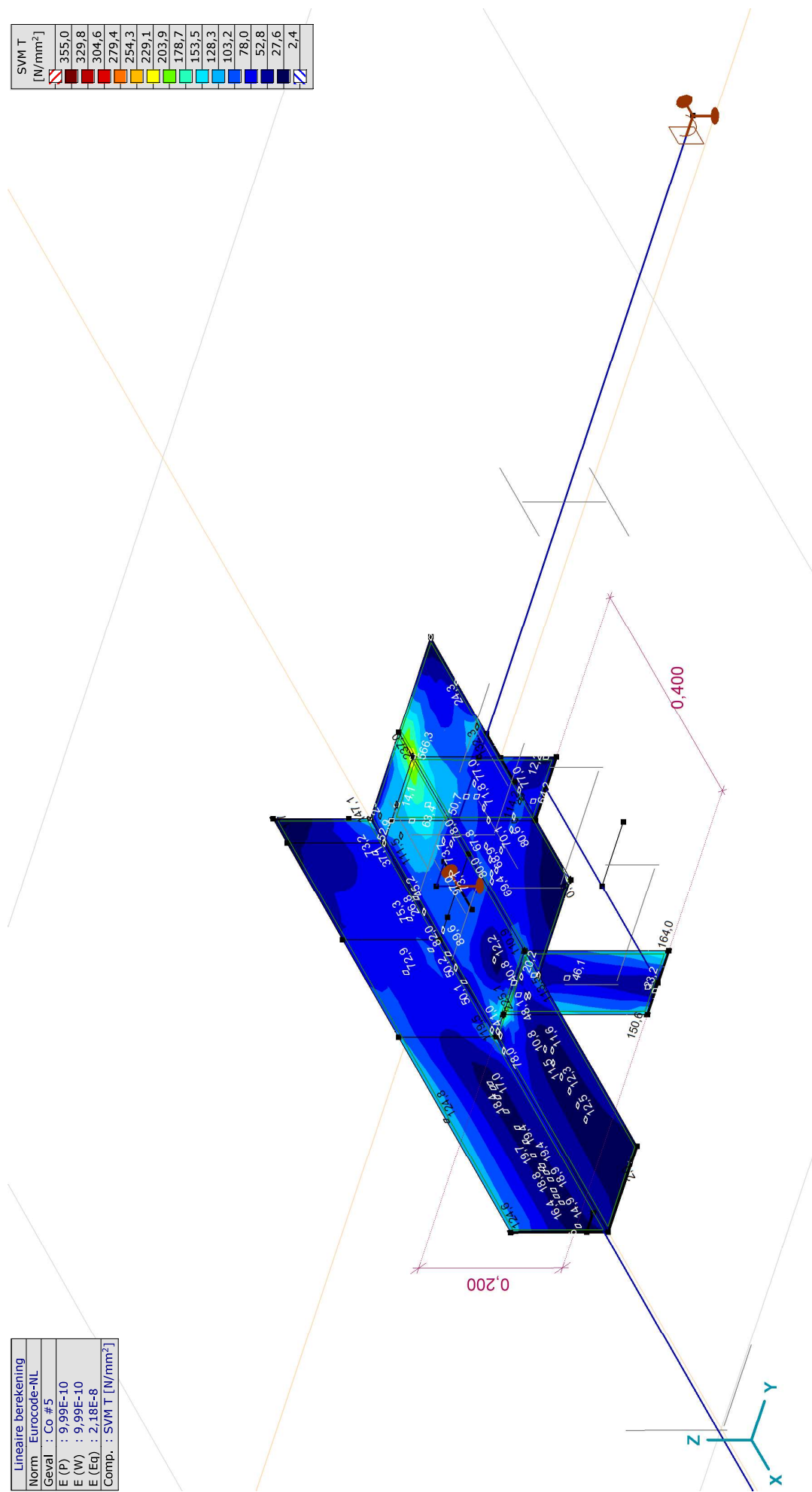

[J], Lineair, Co #5 (UGT), SVM T, Kleuren 2D

**Project:**

Constructeur: DNV GL - Energy  
 Model: Post aan onderrand HA\_s.axes

Lineaire berekening
Norm Eurocode-NL
Geval : Co #6
E (P) : 9,99E-10
E (W) : 9,99E-10
E (Eq) : 2,18E-8
Comp. : SVM T [N/mm <sup>2</sup> ]

SVM T [N/mm <sup>2</sup> ]
355,0
329,8
304,6
279,4
254,3
229,1
203,9
178,7
153,5
128,3
103,2
78,0
52,8
27,6
2,4

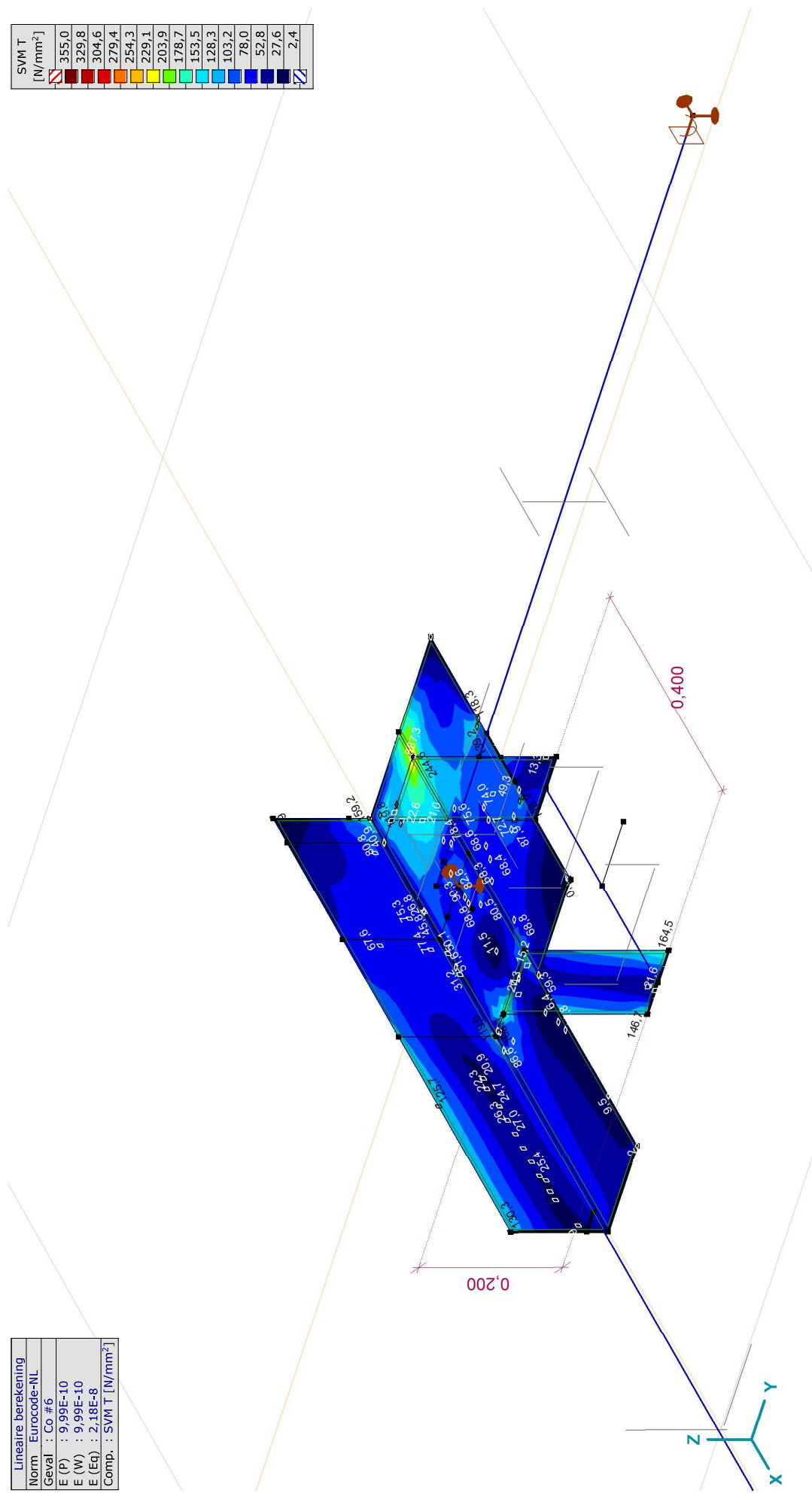

[J], Lineair, Co #6 (UGT), SVM T, Kleuren 2D

**Project:**

Constructeur: DNV GL - Energy

Model: Post aan onderrand HA\_s.axes

18-5-2021

Pag. 35

Lineaire berekening	
Norm	: Eurocode-NL
Geval	: Omhullende Min,Max
Omhullende	: Alle UGT
E (P)	: 9.99E-10
E (W)	: 9.99E-10
E (Eq)	: 2.18E-8
Comp.	: SVM B [N/mm <sup>2</sup> ]

SVM B	[N/mm <sup>2</sup> ]
[Red]	325,2
[Dark Red]	302,0
[Red-Orange]	278,8
[Orange]	255,6
[Yellow-Orange]	232,3
[Yellow]	209,1
[Light Green]	185,9
[Green]	162,7
[Light Blue]	139,4
[Blue]	116,2
[Dark Blue]	93,0
[Very Dark Blue]	69,8
[Darkest Blue]	46,5
[Black]	23,3
[White]	0,1

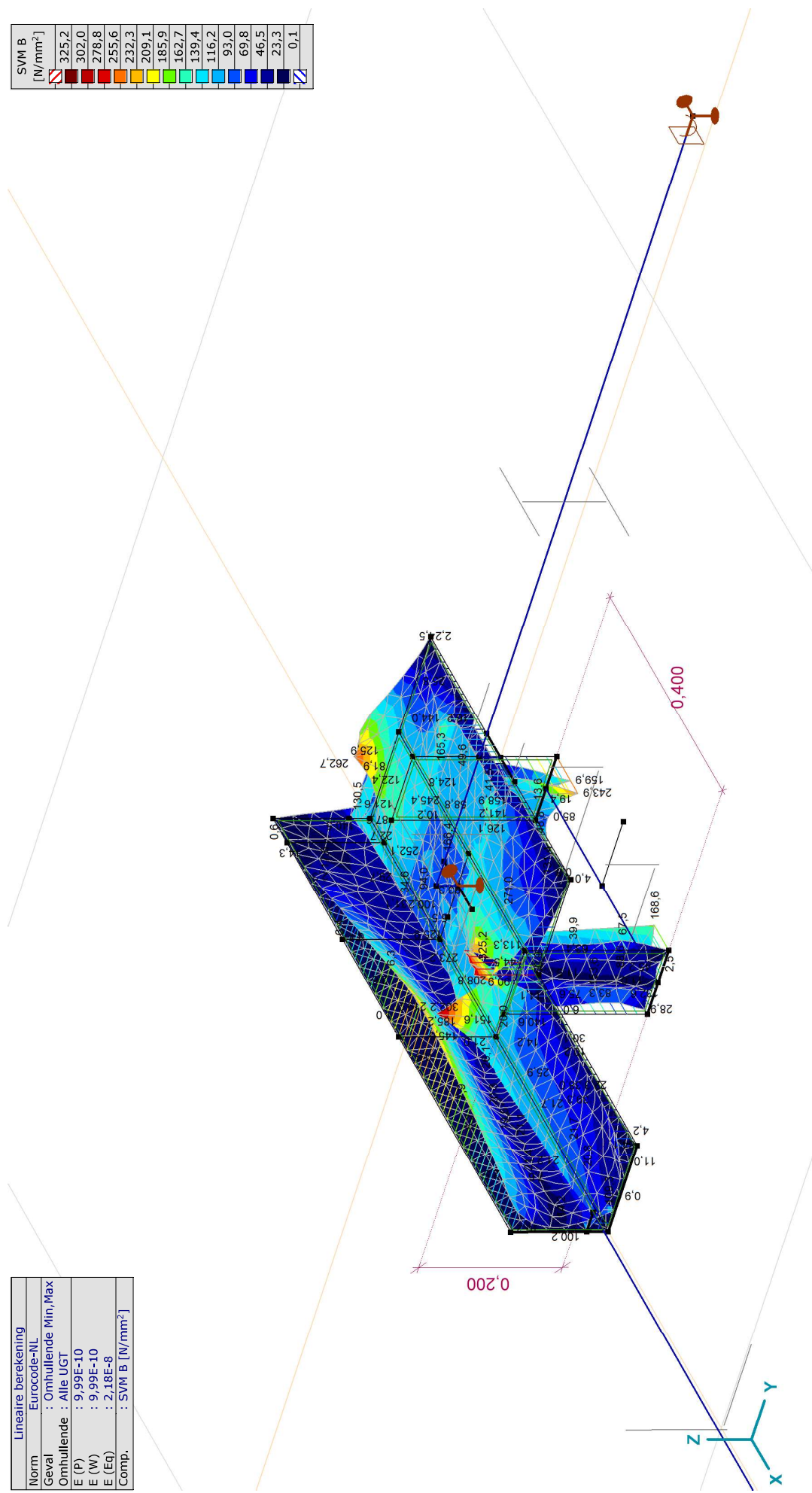

[I], Lineair, Omhullende (Alle UGT), SVM B, Iso vlakken 3D

**Project:**

Constructeur: DNV GL - Energy

Model: Post aan onderrand HA\_s.axes

18-5-2021

Pag. 36

Lineaire berekening	
Norm	: Eurocode-NL
Geval	: Omhullende Min,Max
Omhullende	: Alle UGT
E (P)	: 9.99E-10
E (W)	: 9.99E-10
E (Eq)	: 2.18E-8
Comp.	: SVM C [N/mm <sup>2</sup> ]

SVM C	[N/mm <sup>2</sup> ]
[Red]	392,9
[Dark Red]	364,9
[Red-Orange]	336,8
[Orange]	308,7
[Yellow-Orange]	280,7
[Yellow]	252,6
[Light Green]	224,6
[Green]	196,5
[Light Blue]	168,5
[Blue]	140,4
[Dark Blue]	112,3
[Very Dark Blue]	84,3
[Navy]	56,2
[Black]	28,2
[White]	0,1

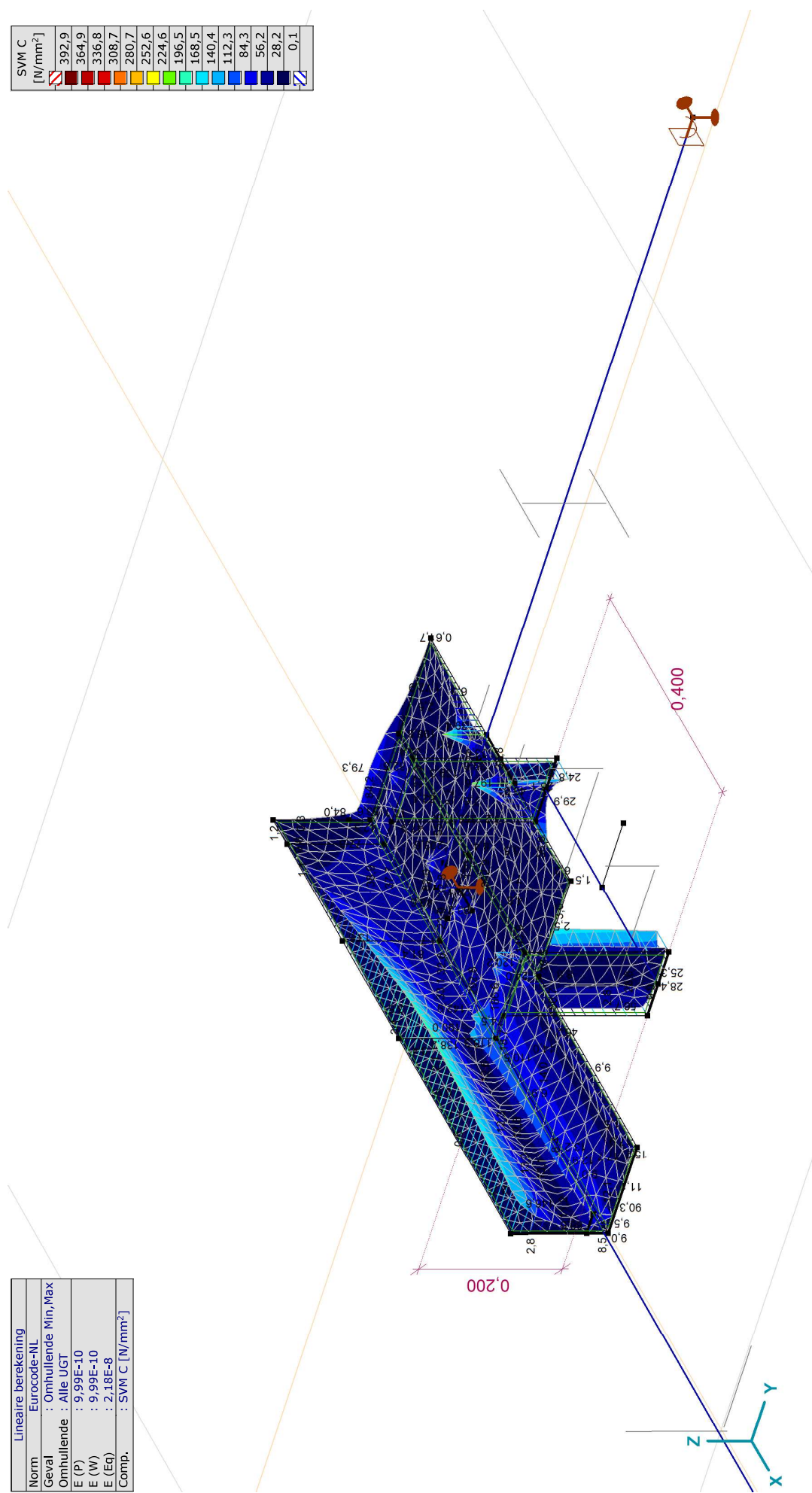

[I], Lineair, Omhullende (Alle UGT), SVM C, Iso vlakken 3D



**Project:**

Constructeur: DNV GL - Energy

Model: Post aan onderrand HA\_s.axes

18-5-2021

Pag. 37

Lineaire berekening	
Norm	: Eurocode-NL
Geval	: Omhullende Min,Max
Omhullende	: Alle UGT
E (P)	: 9.99E-10
E (W)	: 9.99E-10
E (Eq)	: 2.18E-8
Comp.	: SVM T [N/mm <sup>2</sup> ]

SVM T	[N/mm <sup>2</sup> ]
[Red]	587,3
[Dark Red]	545,3
[Red-Orange]	503,4
[Orange]	461,5
[Yellow-Orange]	419,5
[Yellow]	377,6
[Light Green]	335,6
[Green]	293,7
[Light Blue]	251,7
[Blue]	209,8
[Dark Blue]	167,9
[Very Dark Blue]	125,9
[Navy]	84,0
[Black]	42,0
[White]	0,1

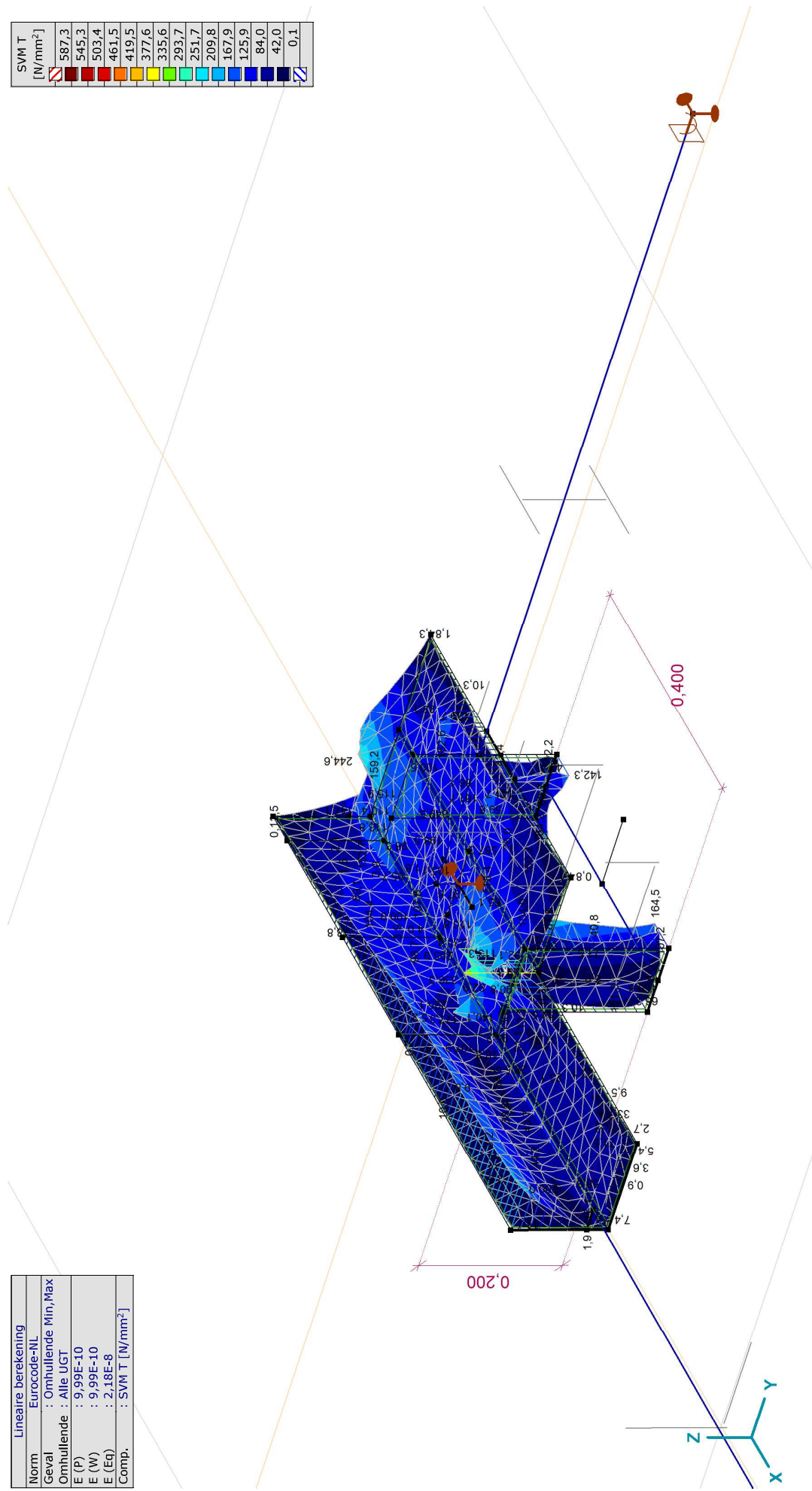

[1], Lineair, Omhullende (Alle UGT), SVM T, Iso vlakken 3D

**Project:**

Constructeur: DNV GL - Energy

Model: Post aan onderrand HA\_s.axes

18-5-2021

Pag. 38

## Vlakspanningen [Lineair, Omhullende (Alle UGT )]

Knoop	C	min. max.	Geval	Oppervlak	Pos.	Sxx [N/mm <sup>2</sup> ]	Syy [N/mm <sup>2</sup> ]	Szz [N/mm <sup>2</sup> ]	Sxy [N/mm <sup>2</sup> ]	Sxz [N/mm <sup>2</sup> ]	Syz [N/mm <sup>2</sup> ]	SVM [N/mm <sup>2</sup> ]	S1 [N/mm <sup>2</sup> ]	S2 [N/mm <sup>2</sup> ]	aS [°]
Ext.															
13	Sxx	min	Co #6	Sch 165	B	-339,3	-198,1	0	37,2	0	0	302,2	-188,9	-348,5	76,10
13		max	Co #5	Sch 165	B	330,1	210,5	0	-47,7	0	0	301,0	346,8	193,8	-19,30
8	Syy	min	Co #5	Sch 65	T	-59,0	-551,7	0	-123,0	0	0	566,3	-30,0	-580,8	-13,27
8		max	Co #6	Sch 65	T	60,8	572,1	0	127,3	0	0	587,3	602,1	30,8	76,76
1	Szz	min	Co #1	Sch 280	T	-7,8	-0,7	0	1,3	0	0	7,8	-0,5	-8,0	80,09
1		max	Co #1	Sch 280	T	-7,8	-0,7	0	1,3	0	0	7,8	-0,5	-8,0	80,09
5	Sxy	min	Co #3	Sch 1	T	53,8	488,3	0	-133,9	0	0	518,4	526,2	15,9	-74,18
35		max	Co #2	Sch 159	T	-263,4	-202,3	0	136,7	0	0	336,3	-92,8	-373,0	51,30
40	Sxz	min	Co #1	Sch 554	C	-0,3	-4,0	0	0	-70,4	-86,0	192,6	-0,3	-4,0	0,59
40		max	Co #3	Sch 554	C	-0,1	3,3	0	0	71,7	89,6	198,8	3,3	-0,1	-89,37
39	Syz	min	Co #1	Sch 550	C	-0,3	-4,0	0	0	68,3	-86,6	191,0	-0,3	-4,0	0,59
39		max	Co #3	Sch 550	C	-0,1	3,3	0	0	-69,9	90,1	197,6	3,3	-0,1	-89,37
21	SVM	min	Co #1	Sch 803	B	0	-0,1	0	0	0	0	0,1	0	-0,1	11,54
8		max	Co #6	Sch 65	T	60,8	572,1	0	127,3	0	0	587,3	602,1	30,8	76,76
1	S1	min	Co #3	Sch 280	T	-2,1	-2,4	0	0,5	0	0	2,4	-1,7	-2,8	37,00
1		max	Co #3	Sch 280	T	-2,1	-2,4	0	0,5	0	0	2,4	-1,7	-2,8	37,00
1	S2	min	Co #4	Sch 280	T	-26,8	-1,4	0	-25,4	0	0	51,3	14,4	-42,6	-58,30
1		max	Co #4	Sch 280	T	-26,8	-1,4	0	-25,4	0	0	51,3	14,4	-42,6	-58,30
1	aS	min	Co #4	Sch 280	T	-26,8	-1,4	0	-25,4	0	0	51,3	14,4	-42,6	-58,30
1		max	Co #4	Sch 280	T	-26,8	-1,4	0	-25,4	0	0	51,3	14,4	-42,6	-58,30

**Knoop:** Index; **C:** Extreme component; **min.** **max.:** Extreme type; **Geval:** Belastinggeval van de extreme; **Oppervlak:** Vlak behorend bij knoop; **Pos.:** Punt voor spanningsberekening; **Sxx:** Normaalspanning in lokale x-richting; **Syy:** Normaalspanning in lokale y-richting;

**Szz:** Normaalspanning in lokale z-richting; **Sxy:** Torsie-/Schuifspanning; **Sxz, Syz:** Draal/alschuifspanning; **SVM:** Von Mises spanning; **S1:** Primaire spanning 1; **S2:** Primaire spanning 2; **aS:** Richting primaire spanning;

**Project:**

Constructeur: DNV GL - Energy

Model: Post aan onderrand HA\_s.axs

Lineaire berekening	
Norm	Eurocode-NL
Geval	: Omhullende Min, Max
Omhullende	: Alle UGT
E (P)	: 9,99E-10
E (W)	: 9,99E-10
E (Eq)	: 2,18E-8
Comp.	: S;x;minmax [N/mm <sup>2</sup> ]

S;x;minmax [N/mm <sup>2</sup> ]
247,0
209,8
172,7
135,5
98,4
61,2
24,1
-13,1
-50,2
-87,3
-124,5
-161,6
-198,8
-235,9
-273,1

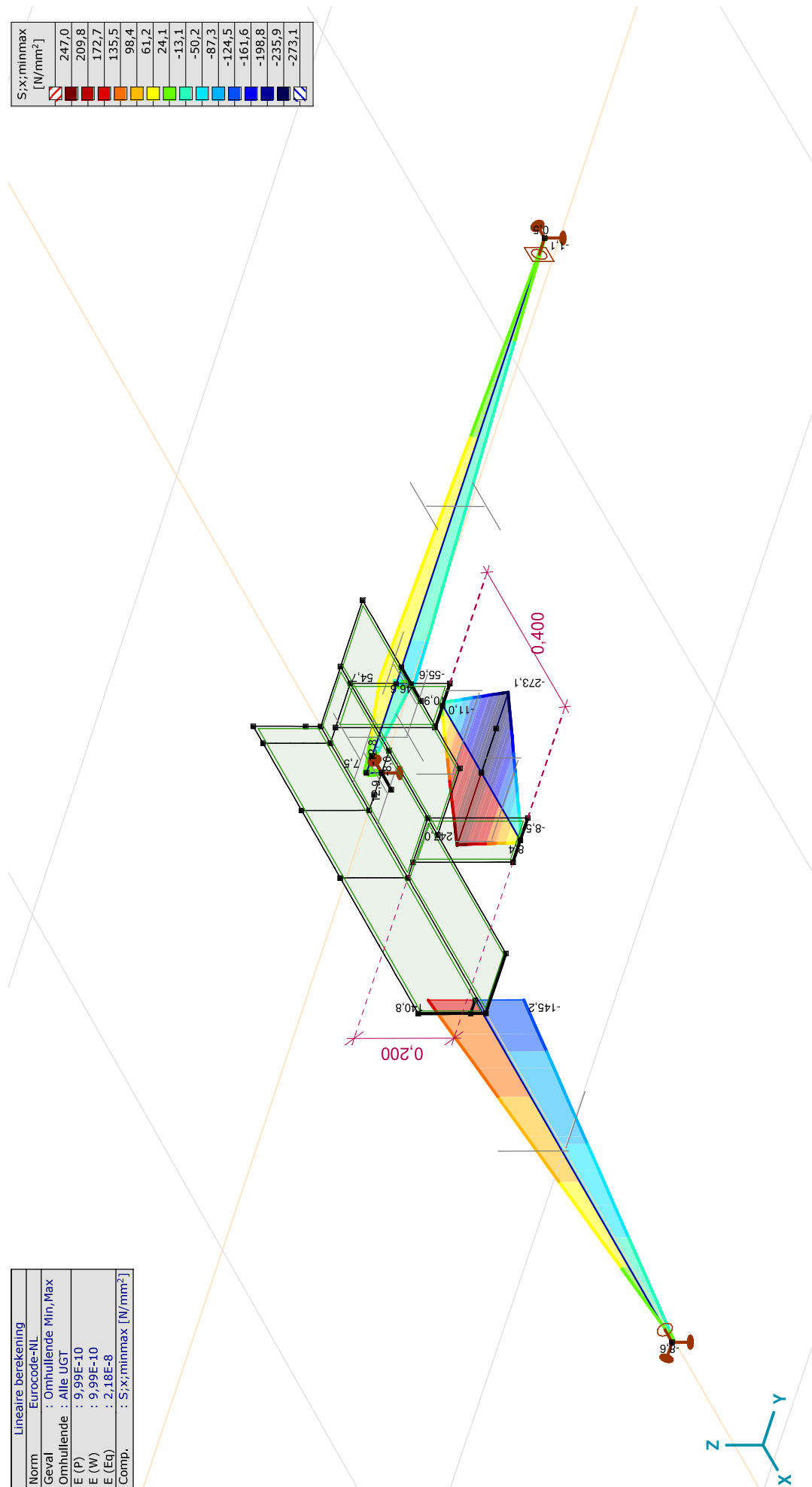

[1], Lineair, Omhullende (Alle UGT), S;x;minmax, Lijnen (gevuld)



**Project:**

Constructeur: DNV GL - Energy

Model: Post aan onderrand HA\_s.axes

18-5-2021

Pag. 40

## Staatspanningen [Lineair, Omhullende (Alle UGT )]

Ext.	Prof.	Doorsnede naam	C	min. max.	Geval	Pos. [m]	Knoop	S <sub>x</sub> :min [N/mm <sup>2</sup> ]	S <sub>x</sub> :max [N/mm <sup>2</sup> ]	V <sub>min</sub> [N/mm <sup>2</sup> ]	V <sub>max</sub> [N/mm <sup>2</sup> ]	S <sub>min</sub> [N/mm <sup>2</sup> ]	S <sub>omax</sub> [N/mm <sup>2</sup> ]	V <sub>y</sub> :gem [N/mm <sup>2</sup> ]	V <sub>z</sub> :gem [N/mm <sup>2</sup> ]
1	1	U 200	S <sub>x</sub> :min	min	Co #4	0,200	(28)	-273,1	99,1	0	54,7	0,8	276,5	-11,0	-0,3
7	3	HE 140 A	max	max	Co #3	0	(38)	9,6	9,6	4,7	11,7	12,6	22,4	-3,2	-0,5
7	3	HE 140 A	S <sub>x</sub> :max	min	Co #1	0	(38)	-9,7	-9,7	2,1	9,9	10,4	19,7	3,9	-0,2
1	1	U 200	max	max	Co #2	0,200	(28)	-89,6	247,0	0	52,2	0,8	250,9	9,9	0,3
1	1	U 200	V <sub>min</sub>	min	Co #1	0	(26)	-0,5	2,0	0	272,2	0,2	471,5	-0,5	-0,4
7	3	HE 140 A	max	max	Co #2	0	(38)	0,5	0,5	34,9	41,0	60,5	71,1	0,4	-3,9
3	4	L 140X140X13	V <sub>max</sub>	min	Co #5	0	(31)	-103,9	64,1	0	5,0	8,6	104,0	-0,1	1,5
1	1	U 200	max	max	Co #3	0	(26)	-2,2	0,5	0	272,6	0,3	472,2	-0,5	0,4
2	1	U 200	max	max	Co #1	0	(28)	-12,4	5,8	0	272,8	0,2	472,5	0,5	0,4
2	1	U 200	S <sub>omin</sub>	min	Co #6	0,200	(27)	-1,7	4,3	0	228,8	0,2	396,3	-6,9	-0,5
7	3	HE 140 A	max	max	Co #2	0,030	(44)	-2,5	3,5	34,9	41,0	60,5	71,1	0,4	-3,9
3	4	L 140X140X13	S <sub>omax</sub>	min	Co #5	1,000	(32)	-8,6	-8,6	0	5,0	8,6	12,2	-0,1	1,5
1	1	U 200	max	max	Co #3	0,200	(28)	-16,5	6,6	0	272,6	0,3	472,2	-0,5	0,4
2	1	U 200	max	max	Co #1	0	(28)	-12,4	5,8	0	272,8	0,2	472,5	0,5	0,4
1	1	U 200	V <sub>y</sub> :gem	min	Co #4	0	(26)	-11,0	3,5	0	54,7	0,8	94,8	-11,0	-0,3
2	1	U 200	max	max	Co #2	0	(28)	-270,5	98,6	0	55,1	0,6	274,1	11,0	0,3
4	3	HE 140 A	V <sub>z</sub> :gem	min	Co #3	0	(33)	-5,0	-0,4	4,0	40,0	6,9	69,3	-0,4	-8,0
4	3	HE 140 A	max	max	Co #1	0	(33)	0,8	4,8	1,7	38,7	3,0	67,0	-0,2	8,0

Prof.: Profiel; C: Extreme component; min. max.: Extreme type; Geval: Belastinggeval van de extreme; Pos.: Lokale X-positie van de doorsnede op de staaf; S<sub>x</sub>:min: Doorsnede minimum normaalspanning; S<sub>x</sub>:max: Doorsnede maximum normaalspanning;V<sub>min</sub>: Doorsnede minimum afschuifspanning; V<sub>max</sub>: Doorsnede maximum afschuifspanning; S<sub>omin</sub>: Doorsnede minimum Von Mises spanning; S<sub>omax</sub>: Doorsnede maximum Von Mises spanning; V<sub>y</sub>:gem: Afschuifspanning in lokale Y-richting; V<sub>z</sub>:gem: Afschuifspanning in lokale Z-richting;

**Project:**

Constructeur: DNV GL - Energy

Model: Post aan onderrand HA\_s.axes

18-5-2021

Pag. 41

## Interne krachten knooppoplegging [Lineair, Omhullende (Alle UGT )]

	Knoop	X [m]	Y [m]	Z [m]	Type	C	min. max.	Geval	Rx [kN]	Ry [kN]	Rz [kN]	Rr [kN]	Rcx [kNm]	Rcy [kNm]	Rrz [kNm]	aR
1	32	1,600	0,030	0,030	Glob.	Ry	min max	Co #4 Co #2		<b>-2,6</b> <b>0,9</b>	8,7 <b>-7,6</b>	9,1 7,6	0 -0,1		0 0,1	0,299 -0,119
						Rz	min max	Co #2 Co #4		0,9 <b>-2,6</b>	7,6 <b>8,7</b>	7,6 9,1	-0,1 0		0 0	-0,119 0,299
2	45	0	1,285	0,030	Glob.	Rx	min max	Co #4 Co #2	<b>-2,1</b> <b>2,6</b>	2,6 -0,9	0,4 -0,3	3,4 2,8		0,1 -0,1	0,1 0,1	9,132 -9,372
						Ry	min max	Co #3 Co #1	0,3 0,1	<b>-1,7</b> <b>3,4</b>	-5,1 5,2	5,4 6,2	0 0	0 0	0 0	-0,346 0,664
						Rz	min max	Co #3 Co #1	0,3 0,1	-1,7 3,4	<b>-5,1</b> <b>5,2</b>	5,4 6,2	0 0	0 0	0 0	-0,346 0,664
3	10	0	0,085	0	Glob.	Rx	min max	Co #4 Co #2	<b>-32,3</b> <b>-28,2</b>		-12,6 4,4	34,7 28,5				-2,571 6,453
						Rz	min max	Co #4 Co #2	-32,3 -28,2		<b>-12,6</b> <b>4,4</b>	34,7 28,5				-2,571 6,453
Ext.																
3	10	0	0,085	0	Glob.	Rx	min max	Co #4 Co #2	<b>-32,3</b> <b>2,6</b>		-12,6 -0,3	34,7 2,8				-2,571 -9,372
2	45	0	1,285	0,030	Glob.	Ry	min max	Co #4 Co #1	<b>-2,6</b> 0,1	-0,9 <b>3,4</b>	8,7 5,2	9,1 6,2	0	-0,1	0	0,299 0,664
3	10	0	0,085	0	Glob.	Rz	min max	Co #4 Co #4	-32,3 -2,6	-2,6 -2,6	<b>-12,6</b> <b>8,7</b>	34,7 9,1	0	0	0	-2,571 0,299

**Knoop:** Ondersteunde knoop; **Type:** Opleggingstype; **C:** Extreme component; **min, max.:** Extremer geval van de extreme; **Rx:** X-component opleggingreactiekracht; **Ry:** Y-component opleggingreactiekracht; **Rz:** Z-component opleggingreactiekracht; **Rr:** Resulterende opleggingreactiekracht; **Rcx:** X-component opleggingreactiemoment; **Rcy:** Y-component opleggingreactiemoment; **Rrz:** Resulterende opleggingreactiemoment; **Rrr:** Resulterende opleggingreactiemoment; **aR:** Verhouding verticale opleggingkracht / horizontale opleggingkracht;

## **Project:**

**Constructeur: DNV GL - Energy**

AxisVM X5 R4h · Geregistreerd aan DNV GL - Energy  
Model 1.axs

**Rapport**

## Rapport, Inhoudsopgave

<i>Onderdeel</i>	<i>Pagina</i>	<i>Onderdeel</i>	<i>Pagina</i>
Tekening	3	Gebruiker gedefinieerde belastingcombinaties uit belastinggevallen	14
Tekening2	4	[I], Linear, Co #1 (UGT), SVM T, Kleuren 2D	15
Materialen	5	[I], Linear, Co #2 (UGT), SVM T, Kleuren 2D	16
Domeinen	5	[I], Linear, Co #1 (UGT), SVM C, Kleuren 2D	17
Lijnopleggingen	6	[I], Linear, Co #2 (UGT), SVM C, Kleuren 2D	18
Fx	7	[I], Linear, Co #1 (UGT), eY, Lijnen	19
Fx: Oppervlak lijnlast	8	[I], Linear, Co #2 (UGT), eY, Lijnen	20
Fy1	9	[I], Linear, Co #1 (UGT), eZ, Lijnen	21
Fy1: Oppervlak lijnlast	10	[I], Linear, Co #2 (UGT), eZ, Lijnen	22
Fy2	11	[I], Linear, Co #1 (UGT), Ry (lijnoppl.), Doorsnedelij	23
Fy2: Oppervlak lijnlast	12	[I], Linear, Co #2 (UGT), Ry (lijnoppl.), Doorsnedelij	24
Fz	13	[I], Linear, Co #1 (UGT), Rz (lijnoppl.), Doorsnedelij	25
Fz: Oppervlak lijnlast	14	[I], Linear, Co #2 (UGT), Rz (lijnoppl.), Doorsnedelij	26

**Project:**

Constructeur: DNV GL - Energy

Model: **Model 1.axs**

21-2-2021

Pag. 3

Norm Eurocode-NL

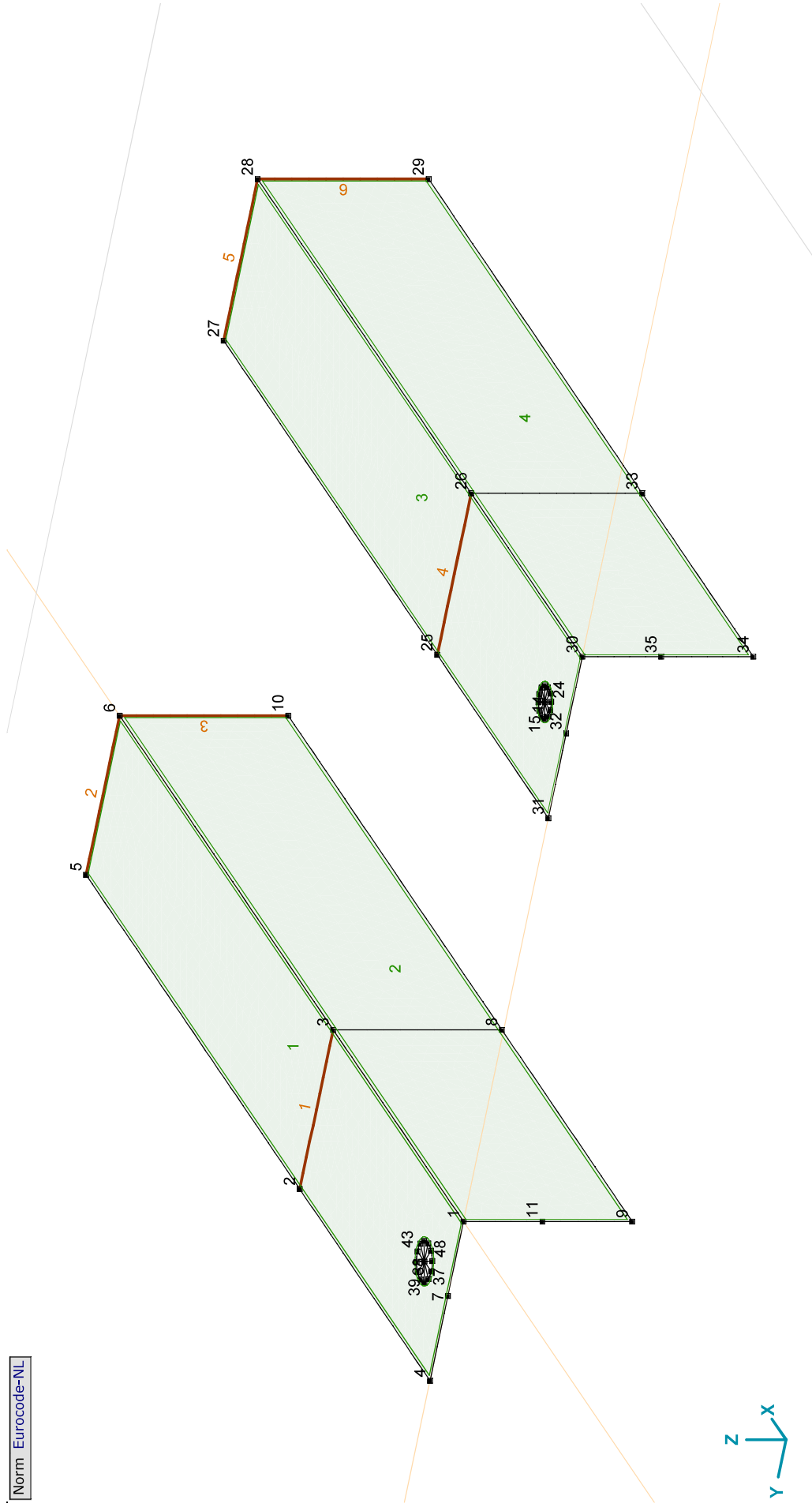

Tekening

**Project:**

Constructeur: DNV GL - Energy

Model: **Model 1.axs**

21-2-2021

Pag. 4

Norm Eurocode-NL

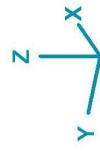
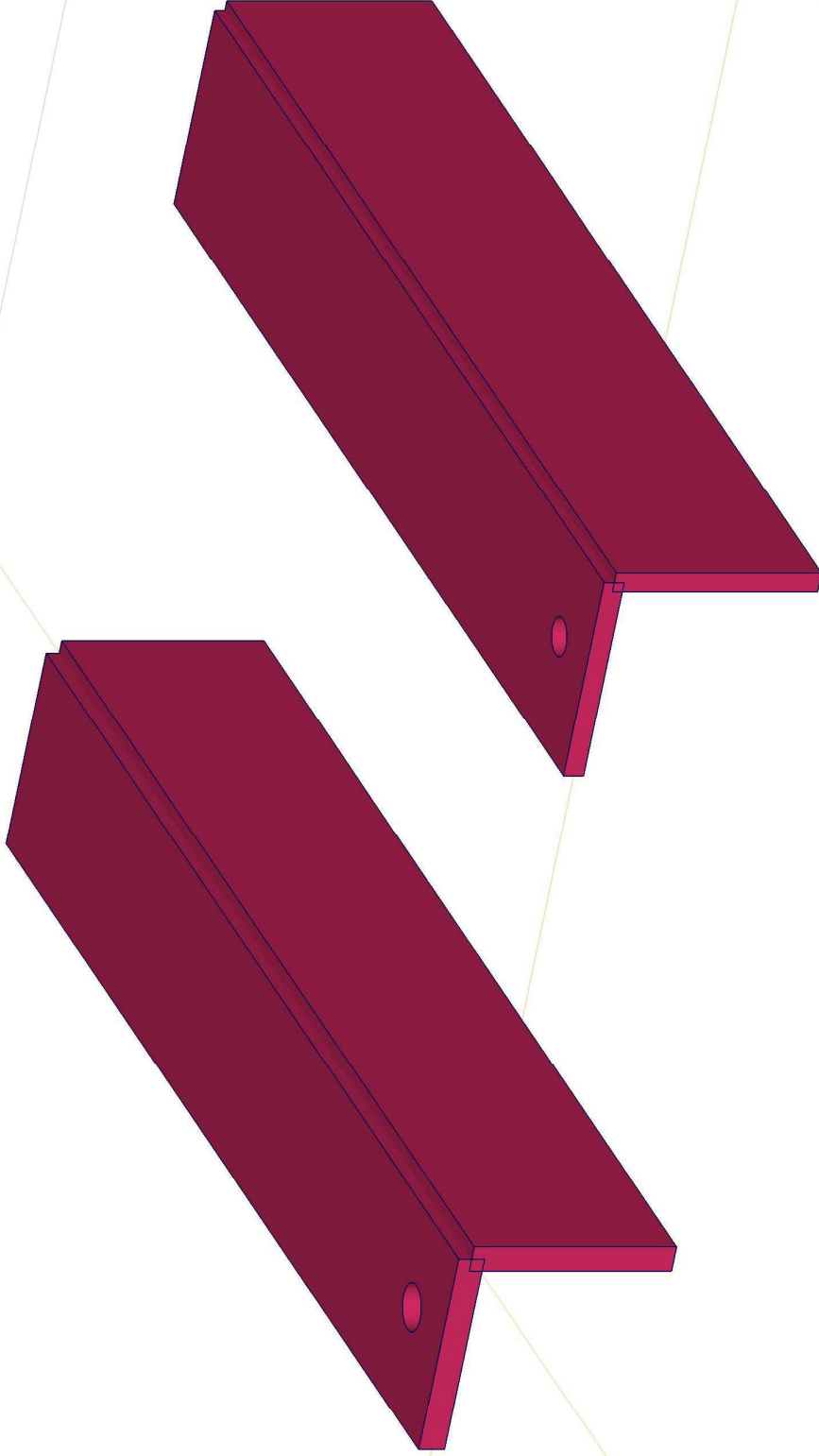

Tekening2

**Project:**



Constructeur: DNV GL - Energy

Model: **Model 1.axs**

21-2-2021

Pag. 5

**Materialen**

Naam	Type	Nationale norm	Materiaalnorm	Model	$E_x$ [N/mm <sup>2</sup> ]	$E_y$ [N/mm <sup>2</sup> ]	$\nu$	$\alpha_T$ [1/°C]	$\rho$ [kg/m <sup>3</sup> ]	Materiaal kleur	Contour kleur	Structuur	
1	S 355	Staal	Eurocode-NL	10025-2	Lineair	210000	210000	0,30	1,2E-5	7850			

Naam	$P_1$	$P_2$	$P_3$	$P_4$	$P_5$	$P_6$	$P_7$	$P_8$	$P_9$	$P_{10}$	$P_{11}$	$P_{12}$	$P_{13}$	$P_{14}$
1	S 355	$f_y$ [N/mm <sup>2</sup> ] = 355,00	$f_u$ [N/mm <sup>2</sup> ] = 510,00	$f_y^*$ [N/mm <sup>2</sup> ] = 335,00	$f_u^*$ [N/mm <sup>2</sup> ] = 470,00									

Naam: Materiaalnaam; Type: Type materiaal; Model: Materiaal model;  $E_x$ : Elasticiteitsmodulus in lokale x richting;  $E_y$ : Elasticiteitsmodulus in lokale y richting;  $\nu$ : Poisson's verhouding;  $\alpha_T$ : Warmteuitzettingscoëfficiënt;  $\rho$ : Dichtheid; **Materiaal kleur**: Materiaalkleur; **Contour Meur**: Contourkleur;  $P_1, P_2, P_3, P_4, P_5, P_6, P_7, P_8, P_9, P_{10}, P_{11}, P_{12}, P_{13}, P_{14}$ : Ontwerpparameter;

**Domeinen**

Element type	Materiaal	Ref <sub>x</sub>	Ref <sub>z</sub>	Dikte [mm]	k, buiging	k, torsie	k, afschuiving	Oppervlakte [m <sup>2</sup> ]	Gat	Mesh
1	# Schaal S 355	Auto	Auto	18				0,113	1	✓
2	# Schaal S 355	Auto	Auto	18				0,114	-	✓
3	# Schaal S 355	Auto	Auto	14				0,108	1	✓
4	# Schaal S 355	Auto	Auto	14				0,109	-	✓

**Element type**: Plaalement type; **Ref<sub>x</sub>**: Referentie voor lokale X-richting; **Ref<sub>z</sub>**: Referentie voor lokale Z-richting; **k, buiging**: Buigsterkte coefficient; **k, torsie**: Torsiesterkte coefficient; **k, afschuiving**: Dwarskrachtsterkte coefficient; **Oppervlakte**: Domein oppervlakte; **Gat**: Aantal gaten in domein; **Mesh**: Gegeneerde mesh;

**Project:**

Constructeur: DNV GL - Energy

Model: **Model 1.axs**

21-2-2021

Pag. 6

**Lijnopleggingen**

Lijn	Type	Ref. elem.	Rx [kN/m/m]	Ry [kN/m/m]	Rz [kN/m/m]	Rxx [kNm/rad/m]	Ryy [kNm/rad/m]	Rzz [kNm/rad/m]	NL(x)	NL(y)	NL(z)
1	Rand (2034)	Domein 1	0	1E+7	1E+7	0	0	0		Symmetrisch	Symmetrisch
2	Rand (1959)	Domein 1	1E+10	0	0	0	0	0	Symmetrisch		
3	Rand (104)	Domein 2	1E+10	0	0	0	0	0	Symmetrisch		
4	Rand (3938)	Domein 3	0	1E+7	1E+7	0	0	0		Symmetrisch	Symmetrisch
5	Rand (3866)	Domein 3	1E+10	0	0	0	0	0	Symmetrisch		
6	Rand (5718)	Domein 4	1E+10	0	0	0	0	0	Symmetrisch		

Lijn	NL(xx)	NL(yy)	NL(zz)	F(x) [kN/m]	F(y) [kN/m]	F(z) [kN/m]	M(x) [kNm/m]	M(y) [kNm/m]	M(z) [kNm/m]
1	Rand (2034)								
2	Rand (1959)								
3	Rand (104)								
4	Rand (3938)								
5	Rand (3866)								
6	Rand (5718)								

Lijn: Ondersteund lijnelement; **Type:** Opleggingstype; **Ref. elem.:** Referentie-element; **Rx, Ry, Rz:** Verplaatsingslijfheid; **Rxx, Ryy, Rzz:** Rotatieslijfheid; **NL(x), NL(y), NL(z), NL(xx), NL(yy), NL(zz):** Niet-lineaire parameters; **F(x):** Weerstand in X-richting; **F(y):** Weerstand in Y-richting; **F(z):** Weerstand in Z-richting; **M(x):** Weerstandsmoment in X-richting; **M(y):** Weerstandsmoment in Y-richting; **M(z):** Weerstandsmoment in Z-richting.



**Project:**

Constructeur: DNV GL - Energy

Model: **Model 1.axs**

21-2-2021

Pag. 7

Norm: Eurocode-NL
Geval: Fx

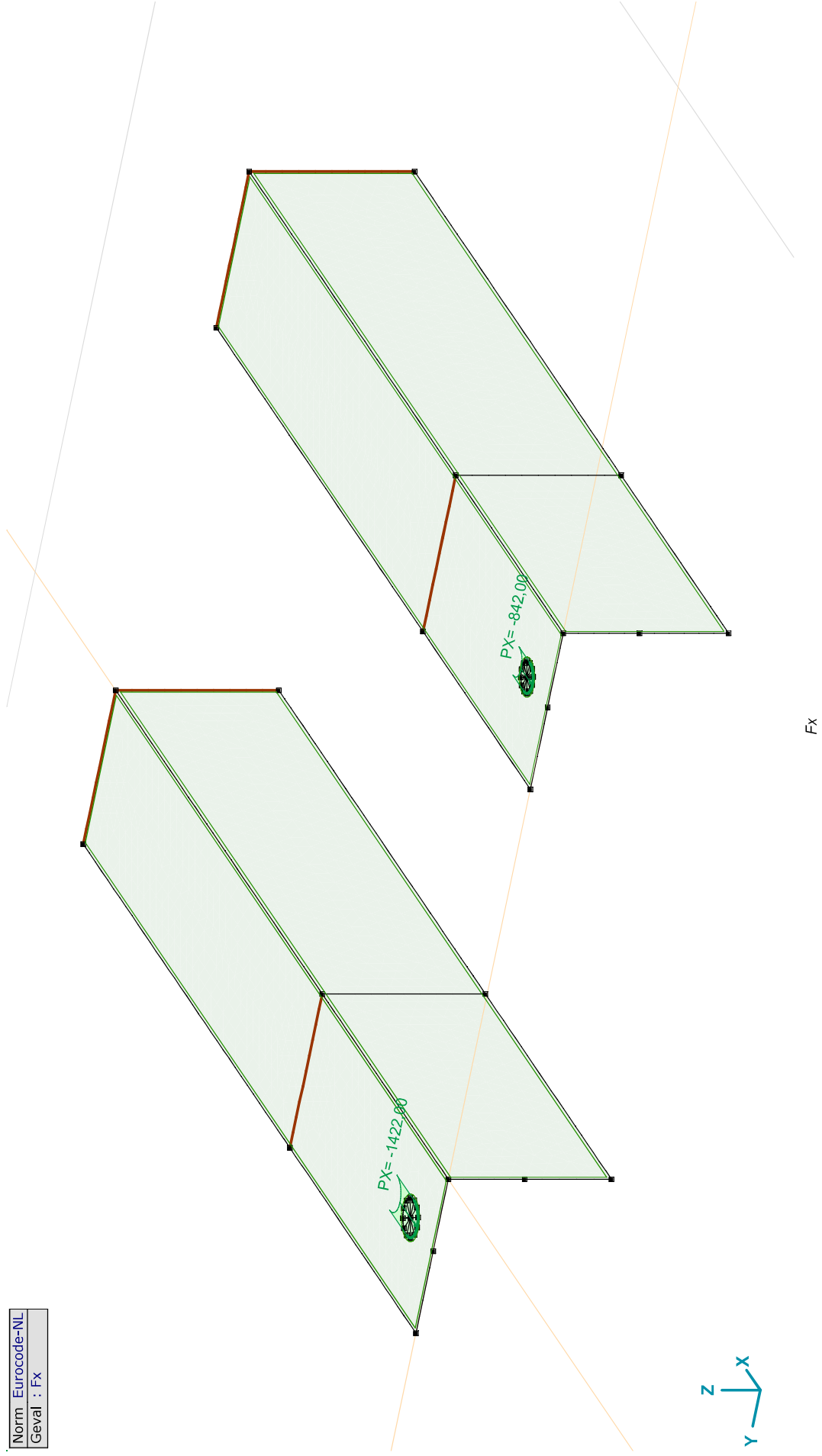

**Project:**

Constructeur: DNV GL - Energy

Model: **Model 1.axis**

21-2-2021

Pag. 8

**Fx: Oppervlak lijnlast**

	<i>Richting</i>	$p_x$ [kN/m]	$p_y$ [kN/m]	$p_z$ [kN/m]	$p_m$ [kNm/m]	$X$ [m]	$Y$ [m]	$Z$ [m]	<i>Richting</i>	$dL$ [m]
1	Global	-1422,00	0	0	0	0,055	0,082	0	(0,055; 0,066; 0,000)	0
		-1422,00	0	0	0	0,055	0,050	0	-	0,050
4	Global	-842,00	0	0	0	0,050	-0,419	0	(0,050; -0,432; 0,000)	0
		-842,00	0	0	0	0,050	-0,445	0	-	0,041

**$p_x$ ,  $p_y$ ,  $p_z$ :** Belastingkracht component;  **$p_m$ :** Belastingmoment component;  **$X$ :** Belasting in X-richting;  **$Y$ :** Belasting in Y-richting;  **$Z$ :** Belasting in Z-richting;

**Project:**

Constructeur: DNV GL - Energy

Model: **Model 1.axs**

21-2-2021

Pag. 9

Norm: Eurocode-NL
Geval: FY1

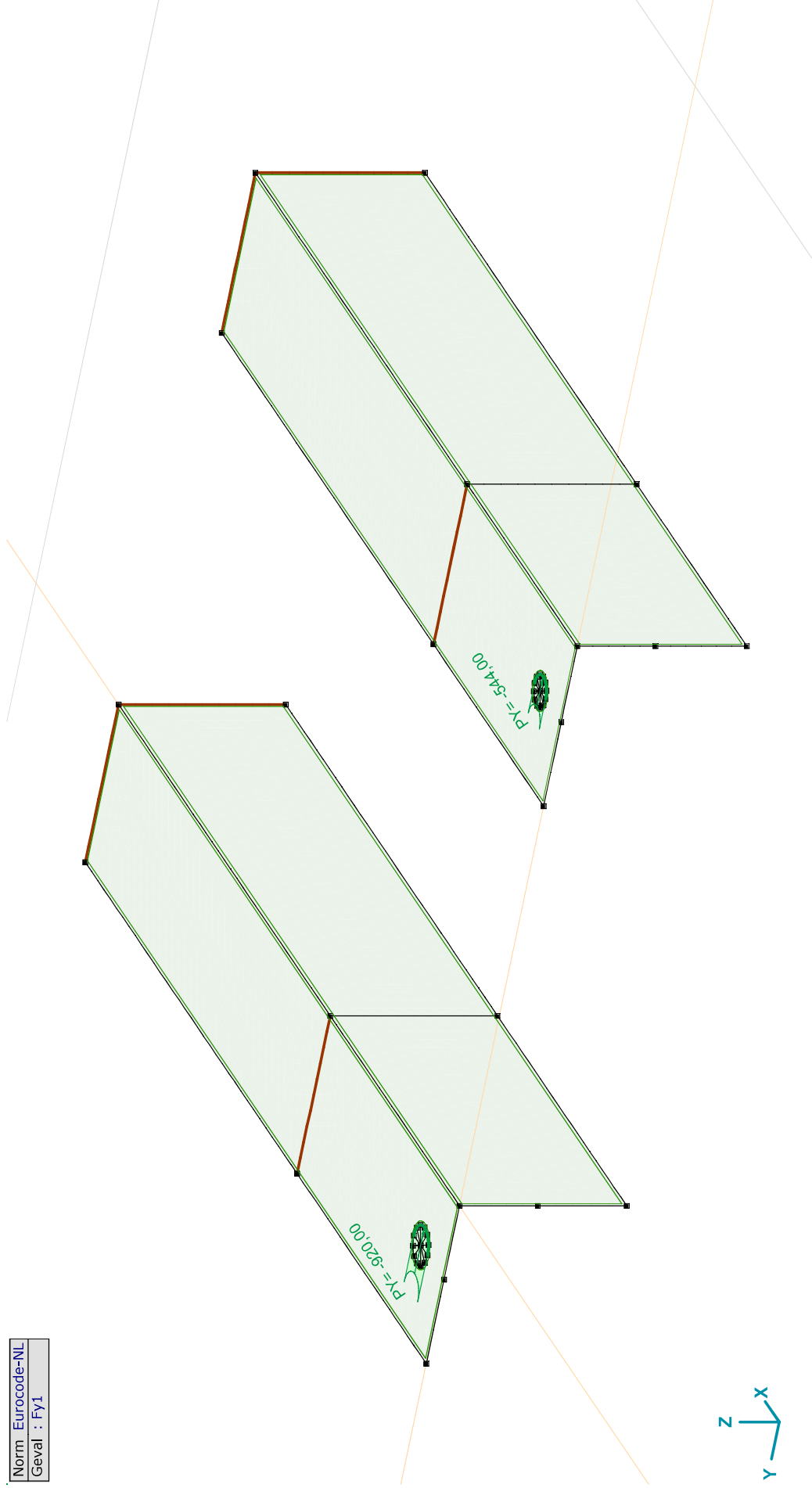

FY1

**Project:**

Constructeur: DNV GL - Energy

Model: **Model 1.axs**

21-2-2021

Pag. 10

**Fy1: Oppervlak lijnlast**

	Richting	$p_x$ [kN/m]	$p_y$ [kN/m]	$p_z$ [kN/m]	$p_m$ [kNm/m]	X [m]	Y [m]	Z [m]	Richting	$dL$ [m]
5	Global	0	-920,00	0	0	0,071	0,066	0	(0,055; 0,066; 0,000)	0
		0	-920,00	0	0	0,039	0,066	0	-	0,050
7	Global	0	-544,00	0	0	0,037	-0,432	0	(0,050; -0,432; 0,000)	0
		0	-544,00	0	0	0,063	-0,432	0	-	0,041

**$p_x$ ,  $p_y$ ,  $p_z$ :** Belastingkracht component;  **$p_m$ :** Belastingmoment component; **X:** Belasting in X-richting; **Y:** Belasting in Y-richting; **Z:** Belasting in Z-richting;

**Project:**

Constructeur: DNV GL - Energy

Model: **Model 1.axs**

21-2-2021

Pag. 11

Norm: Eurocode-NL
Geval: FY2

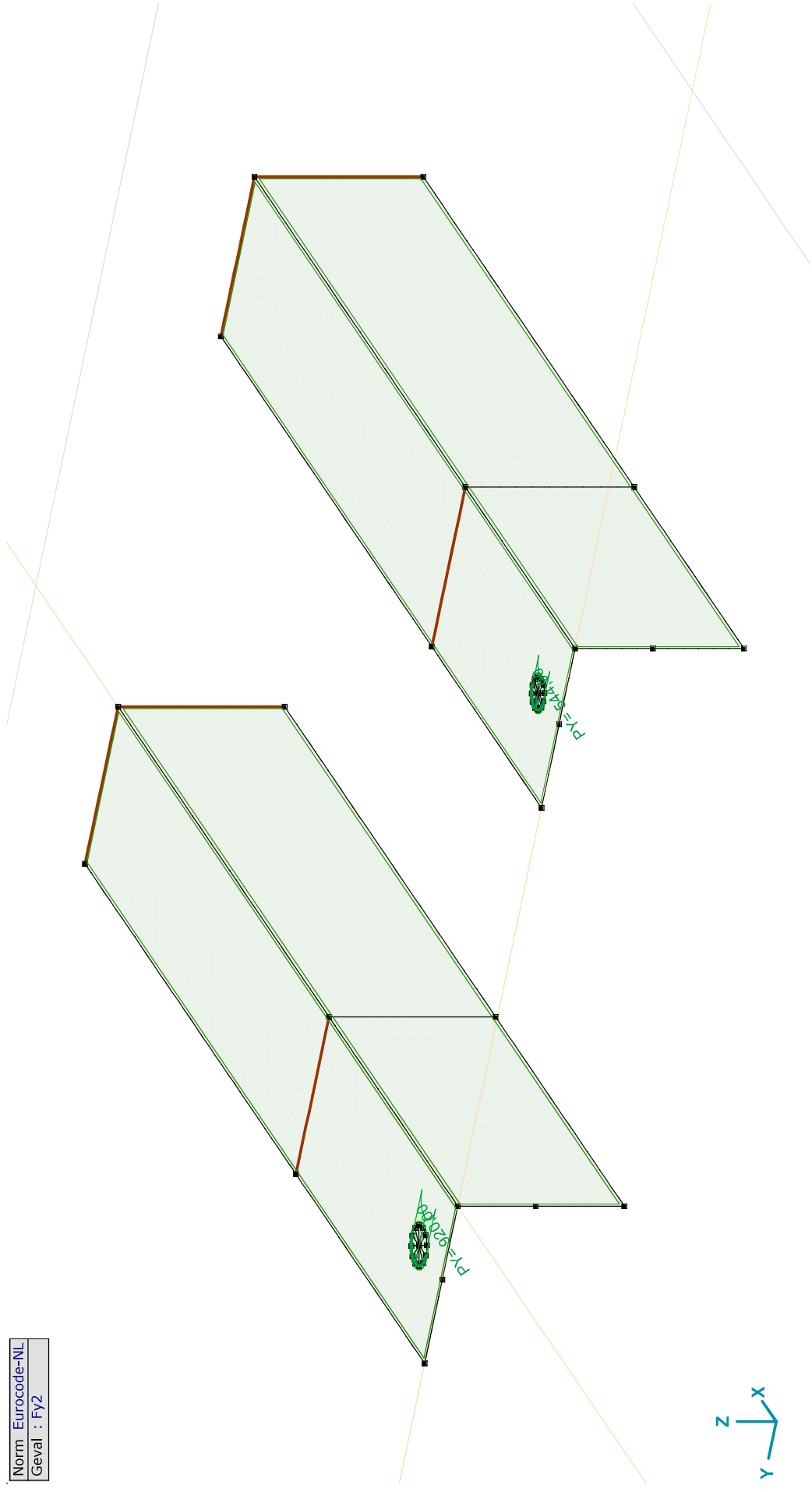

FY2

**Project:**

Constructeur: DNV GL - Energy

Model: **Model 1.axs**

21-2-2021

Pag. 12

**Fy2: Oppervlak lijnlast**

	<i>Richting</i>	$p_x$ [kN/m]	$p_y$ [kN/m]	$p_z$ [kN/m]	$p_m$ [kNm/m]	$X$ [m]	$Y$ [m]	$Z$ [m]	<i>Richting</i>	$dL$ [m]
6	Global	0	920,00	0	0	0,071	0,066	0	(0,055; 0,066; 0,000)	0
		0	920,00	0	0	0,039	0,066	0	-	0,050
8	Global	0	544,00	0	0	0,063	-0,432	0	(0,050; -0,432; 0,000)	0
		0	544,00	0	0	0,037	-0,432	0	-	0,041

**$p_x$ ,  $p_y$ ,  $p_z$ :** Belastingkracht component;  **$p_m$ :** Belastingmoment component;  **$X$ :** Belasting in X-richting;  **$Y$ :** Belasting in Y-richting;  **$Z$ :** Belasting in Z-richting;

**Project:**

Constructeur: DNV GL - Energy

Model: **Model 1.axs**

21-2-2021

Pag. 13

Norm: Eurocode-NL
Geval: Fz

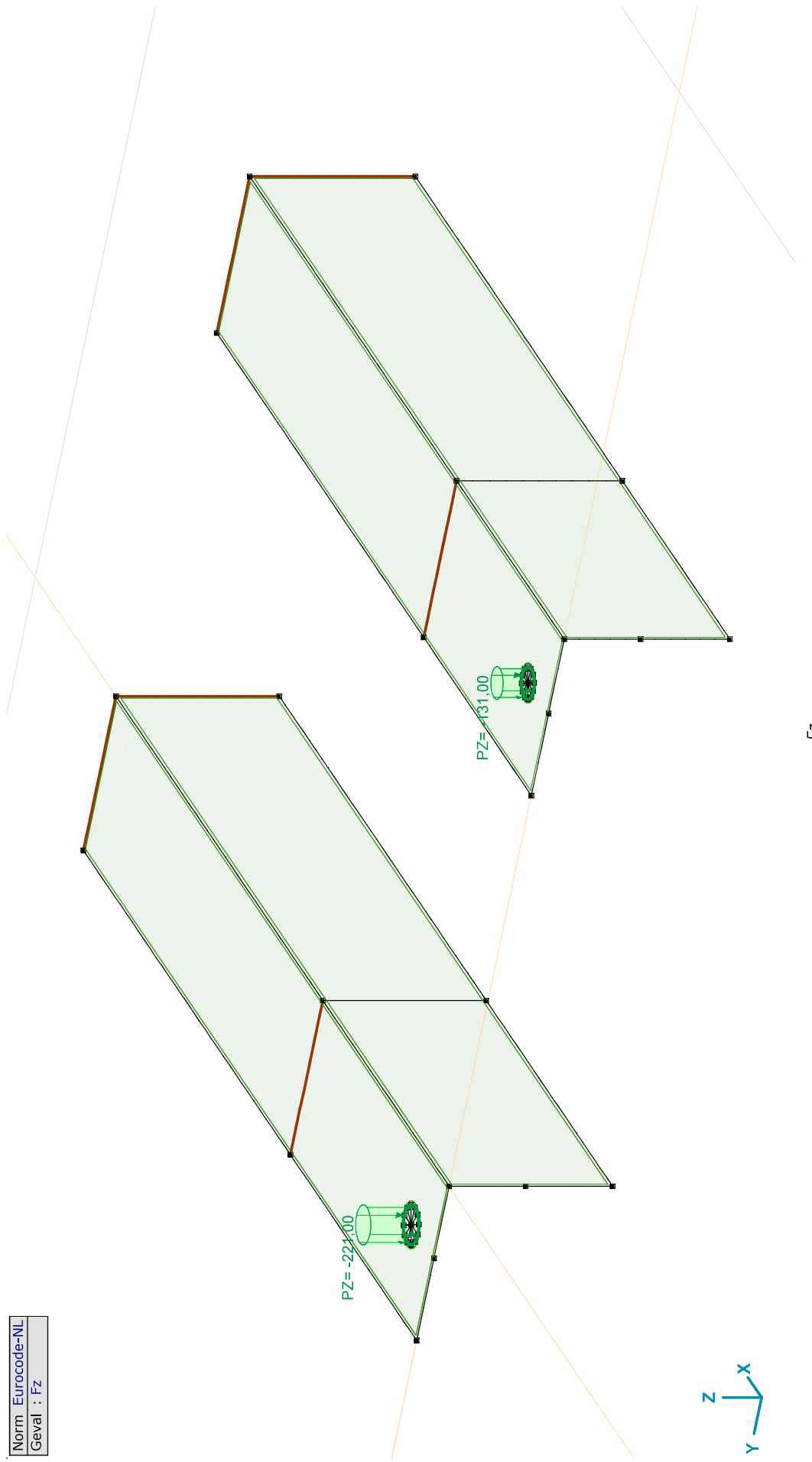

**Project:**

Constructeur: DNV GL - Energy

Model: **Model 1.axs**

21-2-2021

Pag. 14

**Fz: Oppervlak lijnlast**

	<i>Richting</i>	$px$ [kN/m]	$py$ [kN/m]	$pz$ [kN/m]	$pm$ [kN/m/m]	$X$ [m]	$Y$ [m]	$Z$ [m]	<i>Richting</i>	$dL$ [m]
2	Global	0	0	-221,00	0	0,071	0,066	0	(0,055; 0,066; 0,000)	0
		0	0	-221,00	0	0,071	0,066	0	-	0,101
3	Global	0	0	-131,00	0	0,063	-0,432	0	(0,050; -0,432; 0,000)	0
		0	0	-131,00	0	0,063	-0,432	0	-	0,082

**px, py, pz:** Belastingkracht component; **pm:** Belastingmoment component; **X:** Belasting in X-richting; **Y:** Belasting in Y-richting; **Z:** Belasting in Z-richting;

**Gebruiker gedefinieerde belastingcombinaties uit belastinggevallen**

	<i>Naam</i>	<i>Type</i>	$Fx$	$Fy1$	$Fy2$	$Fz$	<i>Commentaar</i>
1	Co #1	UGT	1,00	1,00	0	1,00	
2	Co #2	UGT	1,00	0	1,00	1,00	

**Naam:** Naam belastingcombinatie; **Type:** Type belastingcombinatie; **Fx, Fy1, Fy2, Fz:** Factor;



**Project:**

Constructeur: DNV GL - Energy

Model: **Model 1.axs**

21-2-2021

Pag. 15

Lineaire berekening
Norm Eurocode-NL
Geval : Co #1
E (P) : 7,08E-9
E (W) : 7,08E-9
E (Eq) : 1,32E-10
Comp. : SVM T [N/mm <sup>2</sup> ]

SVM T [N/mm <sup>2</sup> ]
268,35
249,26
230,16
211,07
191,97
172,87
153,78
134,68
115,59
96,49
77,40
58,30
39,20
20,11
1,01

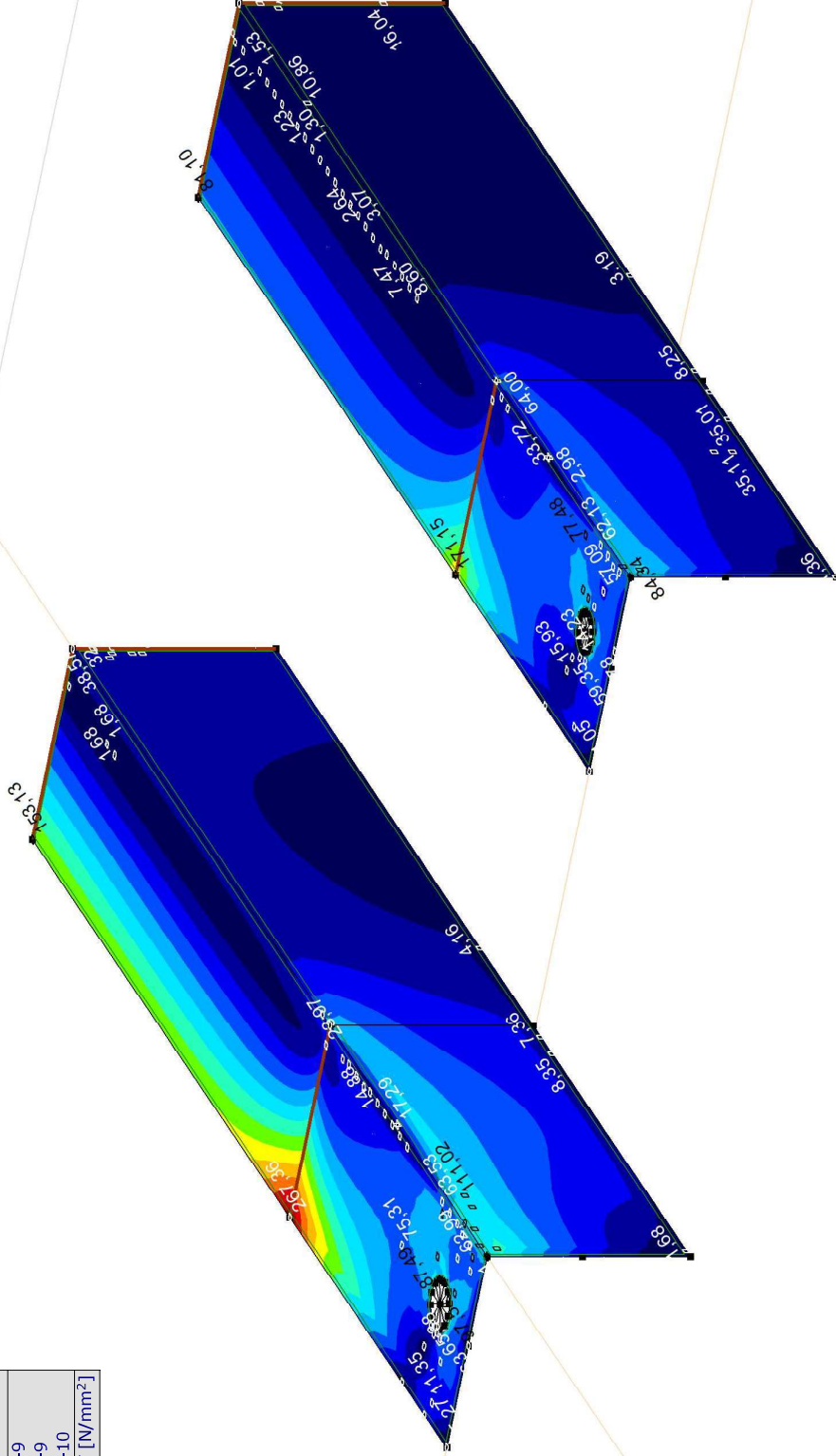

[I]. Lineair, Co #1 (UGT), SVM T, Kleuren 2D

**Project:**

Constructeur: DNV GL - Energy

Model: Model 1.axis

21-2-2021

Pag. 16

Lineaire berekening
Norm Eurocode-NL
Geval : Co #2
E (P) : 7,08E-9
E (W) : 7,08E-9
E (Eq) : 1,32E-10
Comp. : SVM T [N/mm <sup>2</sup> ]

SVM T [N/mm <sup>2</sup> ]
219,10
203,50
187,90
172,30
156,70
141,10
125,50
109,90
94,30
78,70
63,10
47,49
31,89
16,29
0,69

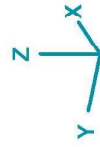
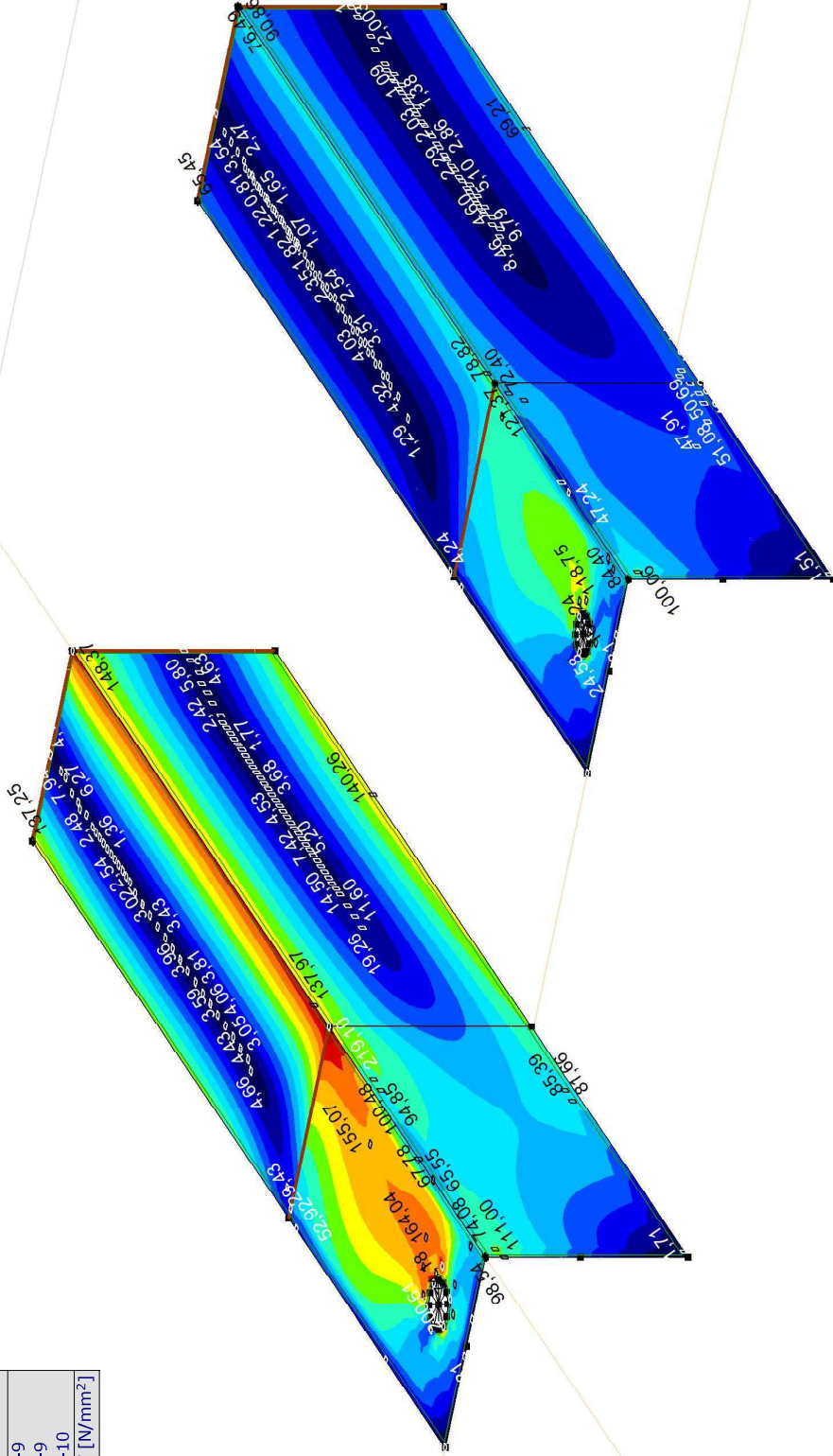

[1]. Lineair, Co #2 (UGT), SVM T, Kleuren 2D

**Project:**  
 Constructeur: DNV GL - Energy  
 Model: **Model 1.axs**

21-2-2021

Pag. 17

Lineaire berekening
Norm Eurocode-NL
Geval : Co #1
E (P) : 7,08E-9
E (W) : 7,08E-9
E (Eq) : 1,32E-10
Comp. : SVM C [N/mm <sup>2</sup> ]

SVM C [N/mm <sup>2</sup> ]
197,50
183,41
169,32
155,23
141,15
127,06
112,97
98,88
84,79
70,71
56,62
42,53
28,44
14,36
0,27

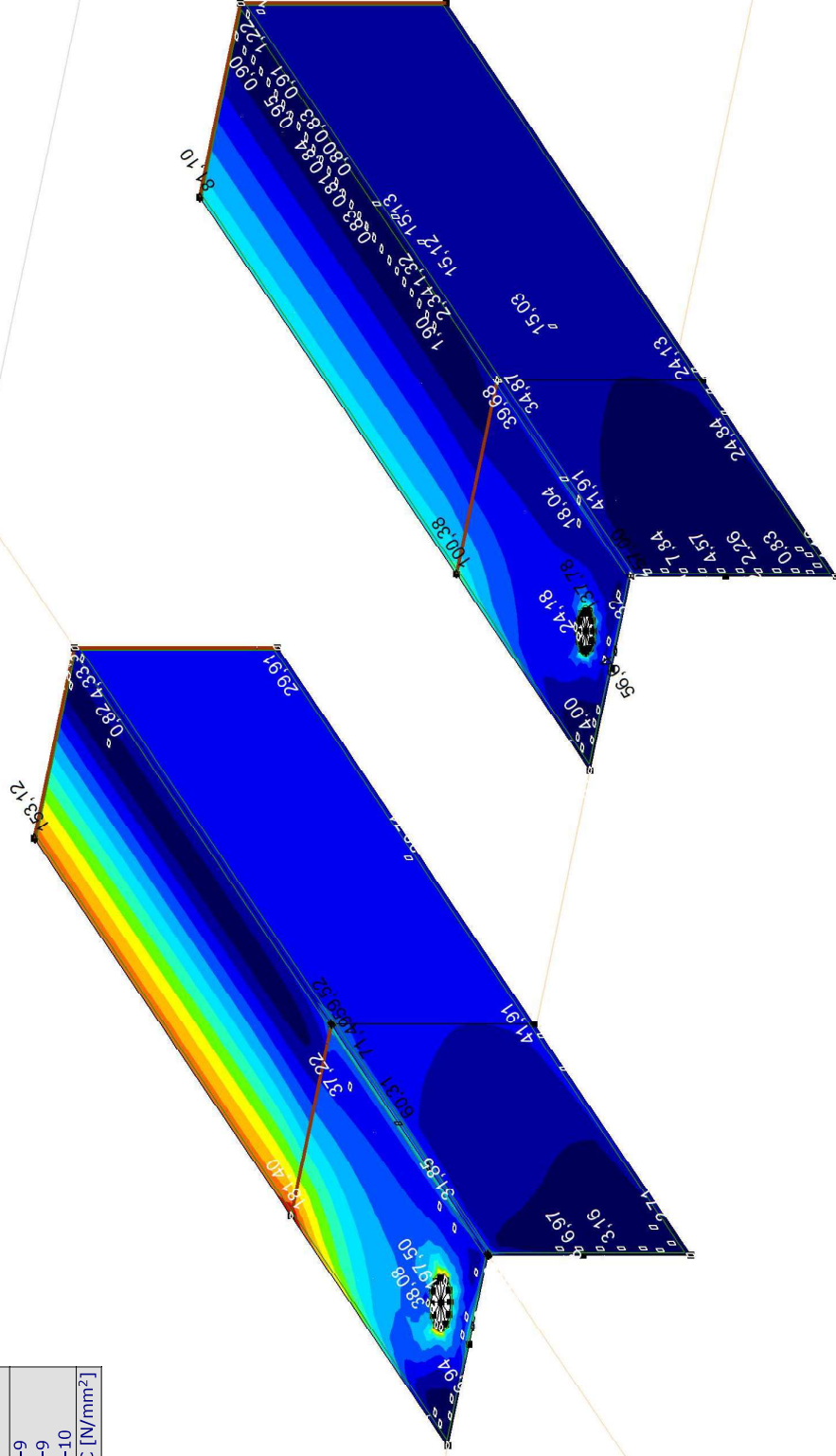

III. Lineair, Co #1 (UGT), SVM C, Kleuren 2D

**Project:**

Constructeur: DNV GL - Energy

Model: Model 1.axs

21-2-2021

Pag. 18

Lineaire berekening
Norm Eurocode-NL
Geval : Co #2
E (P) : 7,08E-9
E (W) : 7,08E-9
E (Eq) : 1,32E-10
Comp. : SVM C [N/mm <sup>2</sup> ]

SVM C [N/mm <sup>2</sup> ]
192,93
179,17
165,42
151,66
137,90
124,14
110,38
96,62
82,86
69,10
55,35
41,59
27,83
14,07
0,31

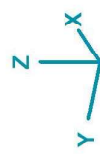
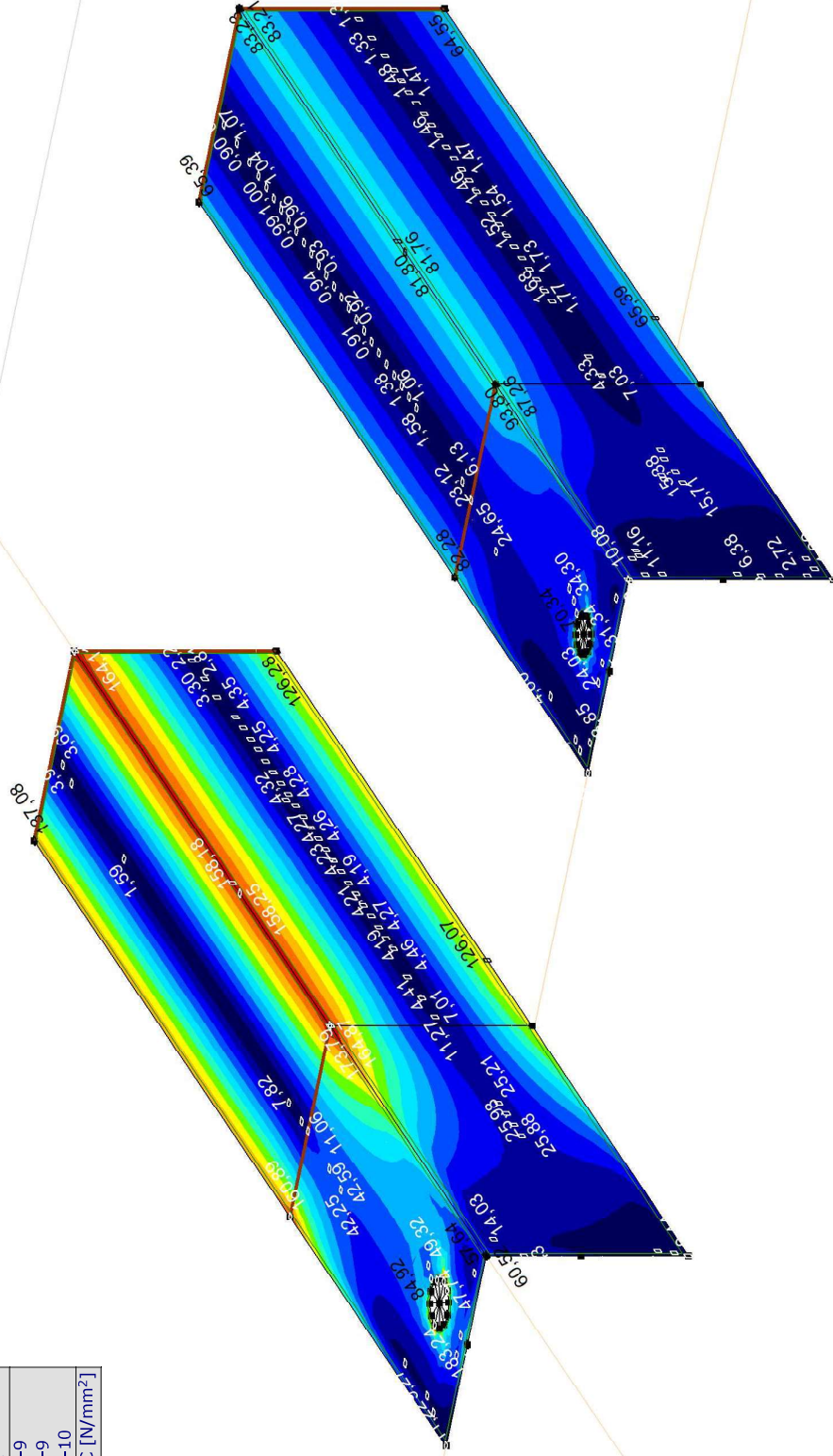

III. Lineair, Co #2 (UGT), SVM C, Kleuren 2D













**Project:**  
 Constructeur: DNV GL - Energy  
 Model: Model 1.axs

21-2-2021

Pag. 23

Lineaire berekening
Norm Eurocode-NL
Geval : Co #1
E (P) : 7,08E-9
E (W) : 7,08E-9
E (Eq) : 1,32E-10
Comp. : Ry [kN/m]

Ry [kN/m]	0
	-28,5
	-57,0
	-85,4
	-113,9
	-142,4
	-170,9
	-199,4
	-227,9
	-256,4
	-284,8
	-313,3
	-341,8
	-370,3
	-398,8

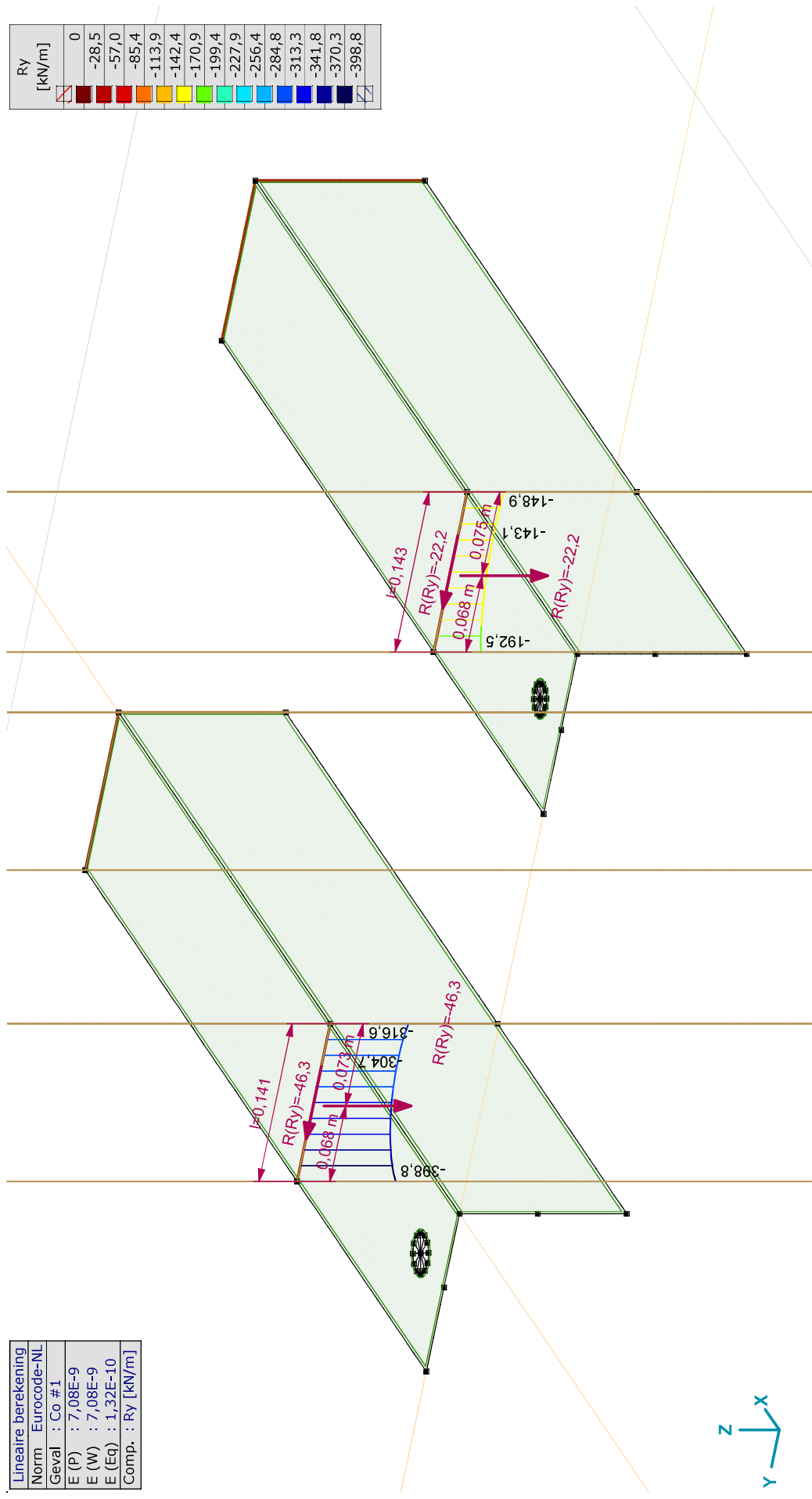

III. Lineair, Co #1 (UGT), Ry (lijnopp.), Doorsnedelij

**Project:**  
 Constructeur: DNV GL - Energy  
 Model: **Model 1.axis**

21-2-2021

Pag. 24

Lineaire berekening	
Norm	Eurocode-NL
Geval	: Co #2
E (P)	: 7,08E-9
E (W)	: 7,08E-9
E (Eq)	: 1,32E-10
Comp.	: Ry [kN/m]

Ry [kN/m]	
386,6	
359,0	
331,4	
303,7	
276,1	
248,5	
220,9	
193,3	
165,7	
138,1	
110,5	
82,8	
55,2	
27,6	
0	

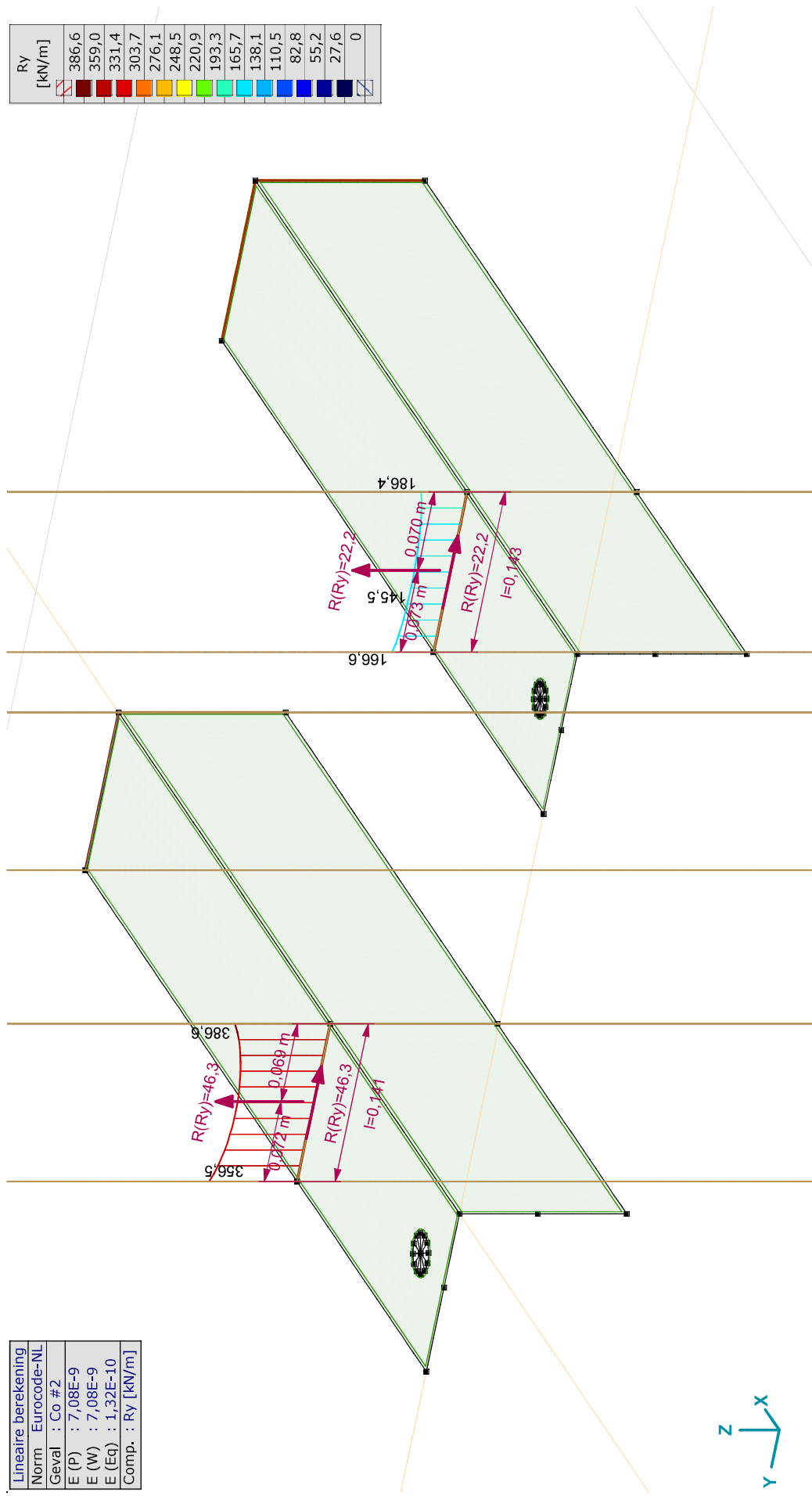

III. Lineair, Co #2 (UGT), Ry (lijnopp.), Doorsnedelij

**Project:**

Constructeur: DNV GL - Energy

Model: **Model 1.axis**

21-2-2021

Pag. 25

Lineaire berekening
Norm Eurocode-NL
Geval : Co #1
E (P) : 7,08E-9
E (W) : 7,08E-9
E (Eq) : 1,32E-10
Comp. : Rz [kN/m]

Rz [kN/m]	0
	-13,5
	-26,9
	-40,4
	-53,9
	-67,3
	-80,8
	-94,3
	-107,7
	-121,2
	-134,7
	-148,1
	-161,6
	-175,1
	-188,6

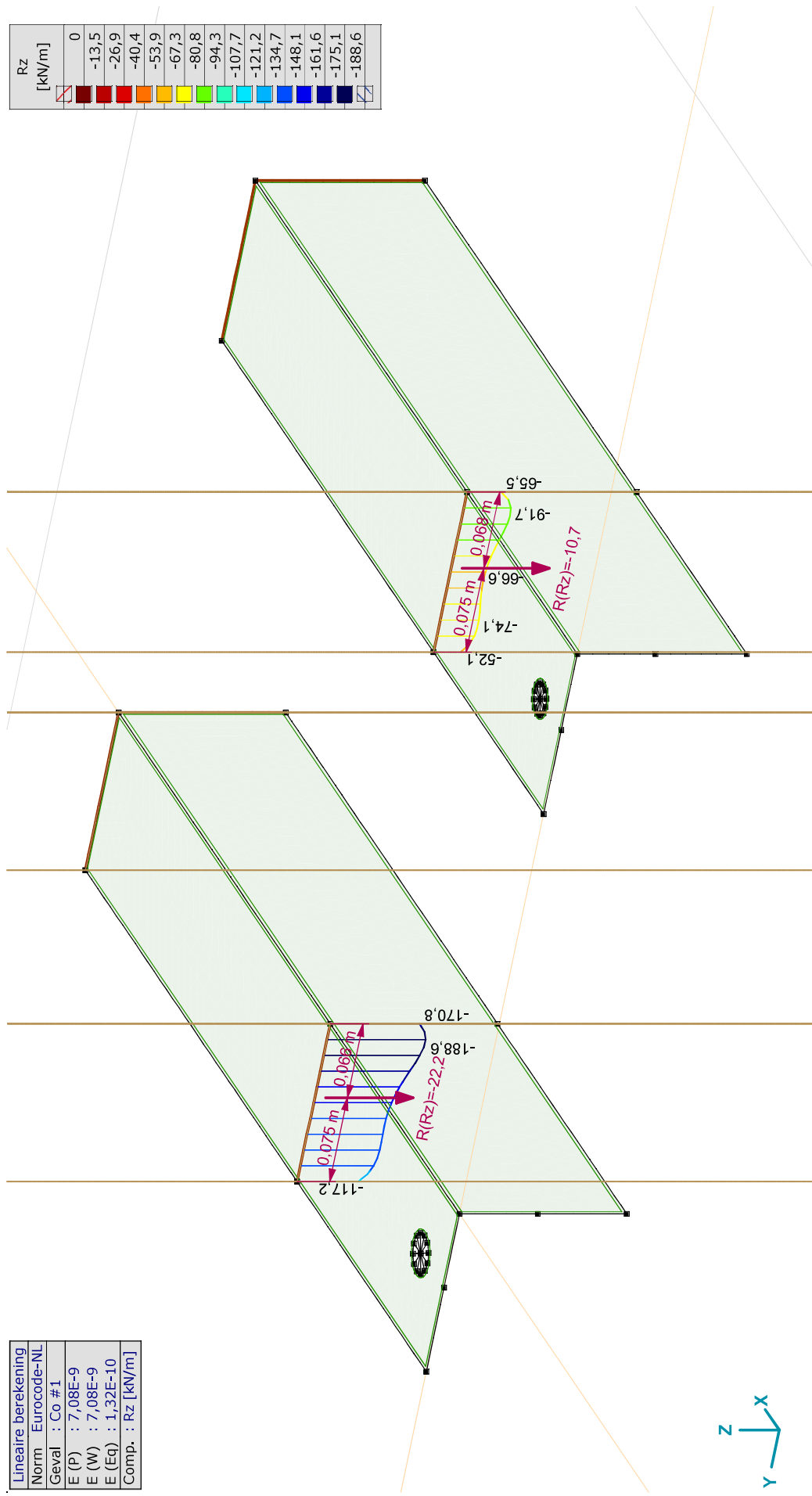

III. Lineair, Co #1 (UGT), Rz (lijnopp.), Doorsnedelij

**Project:**

Constructeur: DNV GL - Energy

Model: **Model 1.axs**

21-2-2021

Pag. 26

Lineaire berekening
Norm Eurocode-NL
Geval : Co #2
E (P) : 7,08E-9
E (W) : 7,08E-9
E (Eq) : 1,32E-10
Comp. : Rz [kN/m]

Rz [kN/m]	0
	-13,0
	-26,0
	-39,1
	-52,1
	-65,1
	-78,1
	-91,1
	-104,1
	-117,2
	-130,2
	-143,2
	-156,2
	-169,2
	-182,3

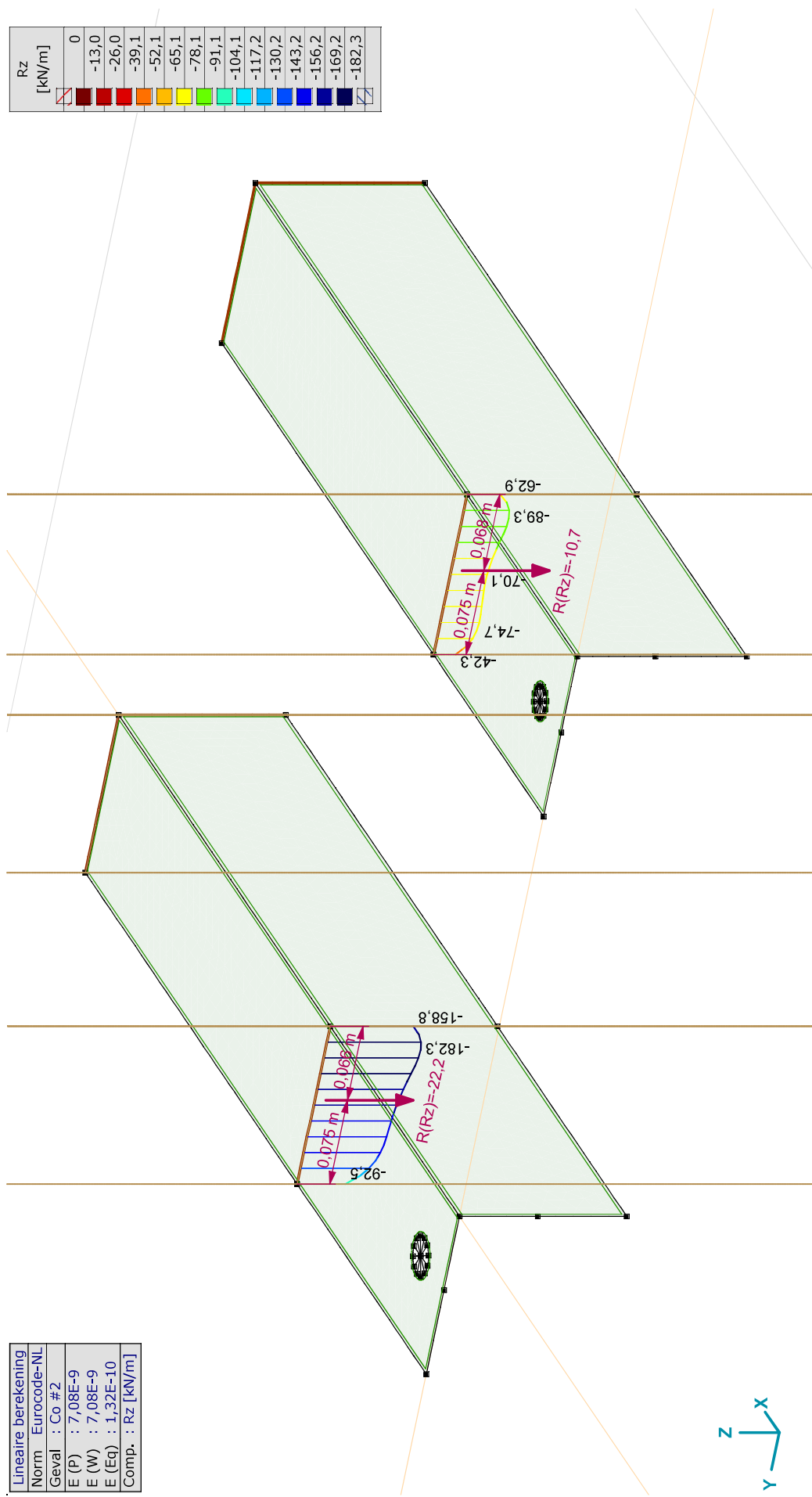

III. Lineair, Co #2 (UGT), Rz (lijnopp.), Doorsnedelij

Project: RLL-TBG  
 Mast: HA+0\_c

**Steel beams in torsion**  
*Calculation of unrestrained beams with eccentric load*

Datum: 2021-02-22  
 Auteur: MRE  
 Versie: 1.1

<b>Load</b>		<b>Beam 1</b>	<b>Beam 2</b>	<b>Beam 3</b>	<b>Beam 4</b>	
Force on insulator		6.88				kN
Angle of insulator (to vertical)		54				°
Horizontal force in direction of Horizontal force	F <sub>h</sub>	5.6				kN
Vertical force	F <sub>v</sub>	4.0				kN
Eccentricity of force (below beam)	e	3375				mm
Torsional moment	T	19.4				kNm
<b>Beams</b>						
Beam length	L	1820				mm
Yield stress	f <sub>y</sub>	355				Mpa
Elastic modulus	E	210000				Mpa
Shear modulus	G	81000				Mpa
Profile		HEB 220				
		HEB220				
Height	h	220				mm
Width	b	220				mm
Web thickness	t <sub>w</sub>	9.5				mm
Flange thickness	t <sub>f</sub>	16.0				mm
Torsional constant	I <sub>t</sub>	77				· 10 <sup>4</sup> mm <sup>4</sup>
Warping constant	I <sub>wa</sub>	295418				· 10 <sup>6</sup> mm <sup>6</sup>
Moment of inertia	I <sub>y</sub>	8091				· 10 <sup>4</sup> mm <sup>4</sup>
	I <sub>z</sub>	2843				· 10 <sup>4</sup> mm <sup>4</sup>
Flange stiffness	I <sub>f</sub> = I <sub>z</sub> / 2 =	1422				mm <sup>3</sup>
Moment of resistance	W <sub>y,el</sub>	736				· 10 <sup>3</sup> mm <sup>3</sup>
	W <sub>z,el</sub>	258				· 10 <sup>3</sup> mm <sup>3</sup>
Torsional bending constant	d	997				mm
	L/d	1.8				
	a	0.5				

**Calculation of second derivative of angular deflection φ'':**

$$\begin{aligned}
 A &= T / (G \cdot I_t \cdot d) = && 3.12E-07 \\
 B &= \sinh(\alpha \cdot L / d) = && 1.04E+00 \\
 C &= \tanh(L/d) = && 9.49E-01 \\
 D &= \cosh(\alpha \cdot L / d) = && 1.45E+00 \\
 F &= \sinh(0.5 \cdot L / d) = && 1.04E+00 \\
 H &= (B / C - D) \cdot F = && -3.61E-01 \\
 X &= A \cdot H = && -1.13E-07 \\
 Y &= X \cdot G \cdot I_t \cdot d / T = && -3.61E-01 \\
 \phi'' &= Y \cdot T / (G \cdot I_t \cdot d) = && -1.13E-07 \quad \text{rad/mm}^2
 \end{aligned}$$

Project: RLL-TBG  
 Mast: HA+0\_c

**Steel beams in torsion**  
*Calculation of unrestrained beams with eccentric load*

Datum: 2021-02-22  
 Auteur: MRE  
 Versie: 1.1

**Acting moments:**

$M_{w,Ed} = E \cdot I_r \cdot (h \cdot t_f) \cdot \phi'' / 2 =$	34.3	<i>kNm</i>
$M_{y,Ed} = 1/4 \cdot F \cdot L =$	1.8	<i>kNm</i>
$M_{z,Ed} = 1/4 \cdot F \cdot L =$	2.5	<i>kNm</i>

**Capacities of beams:**

$M_{w,Rd} = W_{z,el} \cdot f_y / 2 =$	45.9	<i>kNm</i>
$M_{y,Rd} = W_{y,el} \cdot f_y =$	261.1	<i>kNm</i>
$M_{z,Rd} = W_{z,el} \cdot f_y =$	91.8	<i>kNm</i>

**Combined check of beam:**

UC 0,78

**Displacements:**

Factor $F_{ed} / F_k$		1.2	
Displacement y-direction	$u_y$	0.02	<i>mm</i>
Relative displacement	rel.	73062	-
Displacement z-direction	$u_z$	0.10	<i>mm</i>
Relative displacement	rel.	18654	-

## APPENDIX F

### Sterkte-coördinatie

In 5.5.1 van het uitgangspuntenrapport is beschreven dat aan sterkte-coördinatie wordt voldaan als de U.C. van de staven in de traverse 10 procentpunt groter is dan de U.C. van de staven in het mastlichaam. Uitgangspunt is belastingcombinatie 5a, geleiderbreuk. In deze Appendix wordt getoetst of de U.C. van de staven in het mastlichaam voldoende laag is ten opzichte van de U.C. van de staven in de traverse.

Aangezien alle masttypen in de groep van combi-hoekmasten dezelfde mastkop delen, wordt enkel masttype HB+0/c getoetst. Mogelijk dat andere typen een hoger of lager worden belast, maar dat levert geen verschil op in de verhouding van uitnutting tussen de verschillende onderdelen.

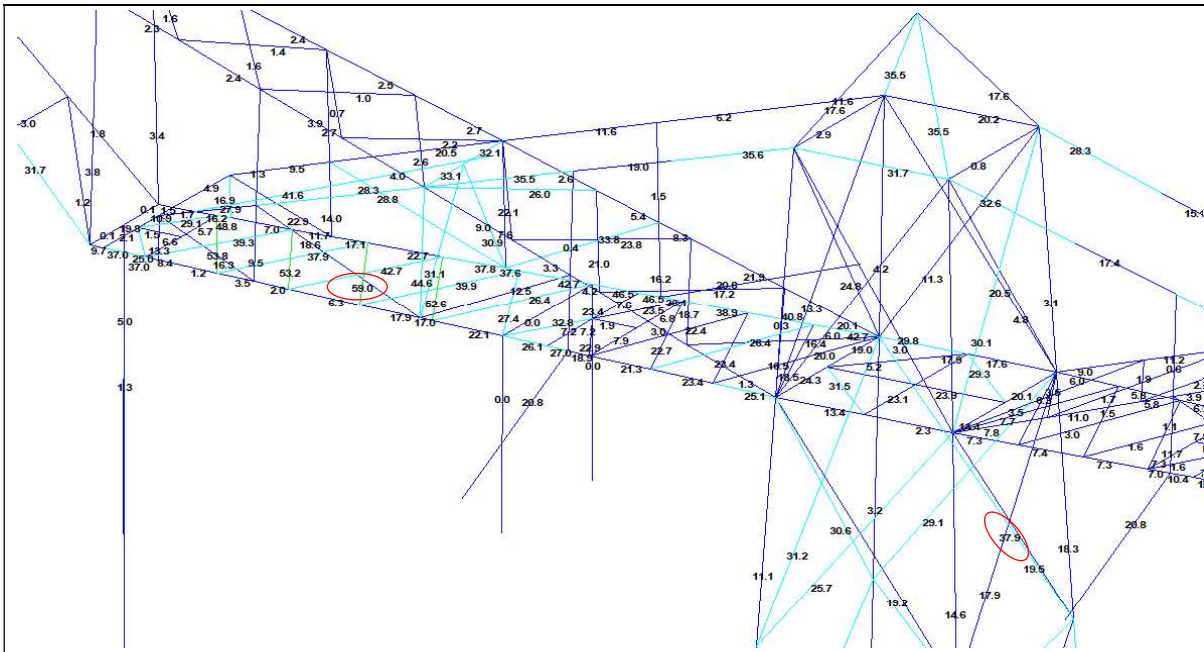

Boventraverse:  $59,0 / 37,9 = 1,56 \geq 1,10$  OK.

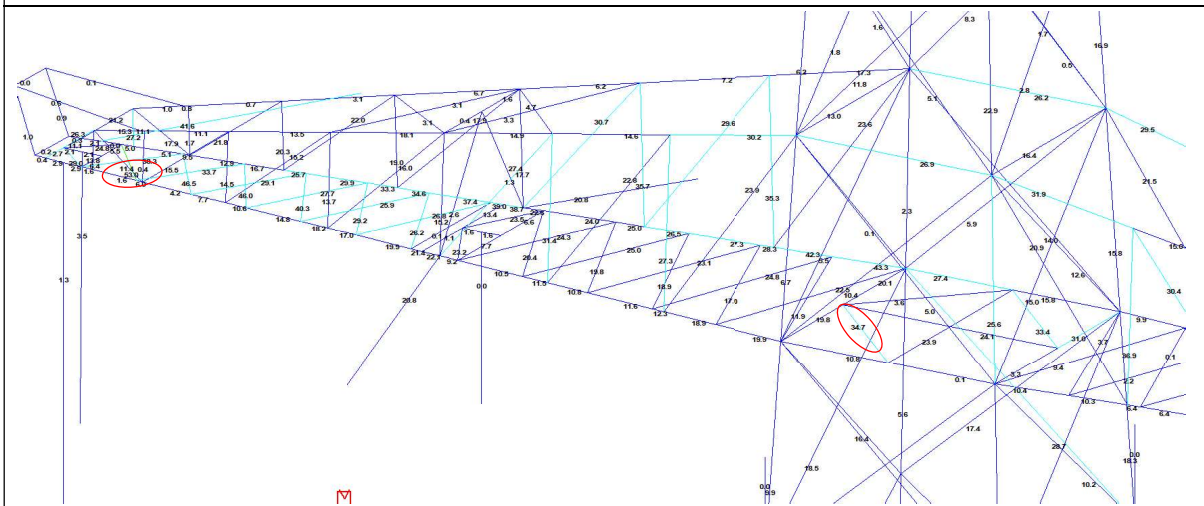

Middentraverse:  $53,0 / 34,7 = 1,53 \geq 1,10$  OK.



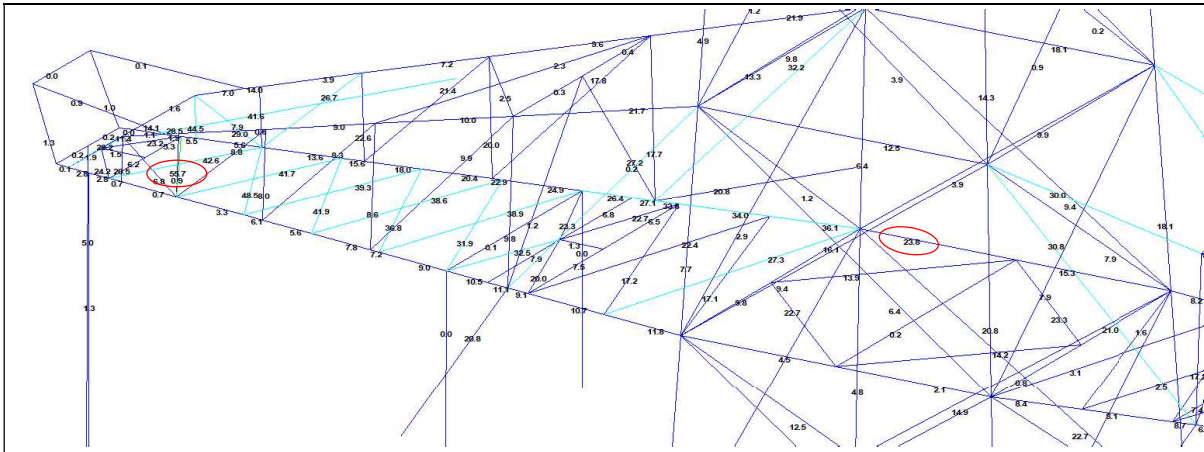

Ondertraverse:  $55,7 / 23,8 = 2,34 \geq 1,10$  OK



## APPENDIX G

### Galloping

#### Uitgangspunten

In het uitgangspuntendocument is beschreven dat wordt uitgegaan van een materiaalfactor voor vermoeiing  $\gamma_{mf} = 1,15$ . Dit komt overeen met de “Safe-life methode” met “Low consequence” van tabel 3.1 van NEN-EN 1993-1-9 of met “Damage tolerant” en “High consequence”.

Assessment method	Consequence of failure	
	Low consequence	High consequence
Damage tolerant	1,00	1,15
Safe life	1,15	1,35

Voor staven met gatverzwakking met bouten in ruime gaten geldt volgens fig. 8.1 van NEN-EN 1993-1-9 categorie 50, met  $m=3$



Voor niet voorgespannen bouten belast op afschuiving geldt volgens fig. 8.1 van NEN-EN 1993-1-9 categorie 100, met  $m=5$ .

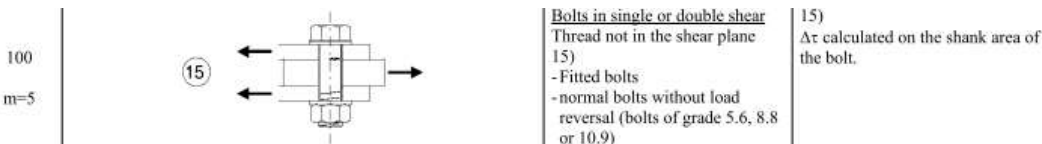

Het belastingspectrum is in de NNA (NEN-EN 50341-2-15) als volgt gedefinieerd.

**Table 4.11/NL.1 Load spectra line galloping for tension supports**

Load spectra line galloping for tension supports		Number of load cycles in 50 years	
Number	Peak-to-peak load	Ice region A	Ice region B
1	2·EDS	7.000	3.000
2	1,5·EDS	36.000	17.000
3	1,0·EDS	125.000	65.000
4	0,5·EDS	482.000	265.000

#### Aanpak

De vier belastingen van 0,5 tot 2,0EDS hebben een vaste onderlinge verhouding. Aangezien het aantal wisselingen zich in het  $m=3$  gebied van de vermoeiingskromme bevindt vanwege  $n < 2 \times 10^6$ , kan een relatie worden afgeleid tussen de grootte van de spanningswissel met bijvoorbeeld 1,0EDS en de spanningswisseling die bij  $2 \times 10^6$  wisselingen op basis van het spectrum nog net toelaatbaar is. Dit staat bekend als de equivalente spanningen methode. Via de factor lambda kan de spanningswisseling worden berekend.

$$\lambda = \left[ \frac{\sum \Delta\sigma_i^m \cdot n_i}{2 \cdot 10^6} \right]^{\frac{1}{m}}$$

Toepassen van de formule voor een spanning van 1 N/mm<sup>2</sup> bij 1,0EDS levert:

Helling IJsgebied Wisseling	m=3		m=5	
	A	B	A	B
	$\sigma_1^m \times n_i$	$\sigma_1^m \times n_i$	$\sigma_1^m \times n_i$	$\sigma_1^m \times n_i$
2,0EDS	5,60E+04	2,40E+04	2,24E+05	9,60E+04
1,5EDS	1,22E+05	5,74E+04	2,73E+05	1,29E+05
1,0EDS	1,25E+05	6,50E+04	1,25E+05	6,50E+04
0,5EDS	6,03E+04	3,31E+04	1,51E+04	8,28E+03
$\Sigma \sigma_1^m \times n_i$	3,63E+05	1,80E+05	6,37E+05	2,98E+05
$\lambda = (\Sigma \sigma x n_i / 2 \times 10^6)^{1/m}$	0,57	0,45	0,80	0,68

Voor ijsgebied A is de toelaatbare spanningswisseling bij 1,0 EDS en 125.000 wisselingen dus 1/0,57 (175%) van de toelaatbare spanningswisseling bij een aantal wisselingen van  $2,0 \times 10^6$ . Er kan ook worden gesteld dat als de spanningswisselingen van 1,0 EDS 363.000 maal voorkomen, dezelfde schade wordt behaald als de vier niveaus afzonderlijk. Deze aanpak is gehanteerd.

- In de berekening van de mast wordt telkens één afspanpunt van de geleiders belast met een trekkracht in lijnrichting van 1,0 EDS.
- Het aantal wisselingen dat deze trekkracht voorkomt wordt vergroot om het hele spectrum te vervangen, dit is afhankelijk van ijsgebied en m-factor.
- Voor iedere staaf in de constructie wordt de schade berekend als gevolg van de trekkracht voor elke geleider.
- De schade wordt gesommeerd over alle geleiders.
- De toetsing is uitgedrukt als de verhouding tussen de optredende spanningswisseling bij  $n = 2 \times 10^6$  wisselingen en de toelaatbare spanningswisseling (43 MPa voor het staalprofiel en 87 MPa voor de bout).

### Resultaten

In de tabellen zijn de resultaten van mast HB+6/c gegeven. Vanwege de exponentiële invloed van het spanningsniveau heeft de verdeling van de U.C.'s een grote variatie. Het meest zwaar belast zijn de diagonalen in het ondervlak van de traverse in de nabijheid van de afspanpunten en de randen van de traverse. De conclusie is dat de staven en bouten voldoen.



**Check galloping - 140gr**

Datum: 16-7-2021  
 Auteur: TBR  
 Versie: 1.0

**RLI-TBG  
 HB+6/c**

Group	Omschrijving	Profiel	Aantal bouten	Bout	Controle netto oppervlak profiel										Controle boutdoorsnede					
					$\Delta F_i$ [kN]	Brutto [mm <sup>2</sup> ]	Netto [mm <sup>2</sup> ]	$\Delta \sigma_i$ [Mpa]	DC <sub>i</sub> [Mpa]	$\Delta \sigma_{c,i}$ [Mpa]	UC opp.	$\Delta F_{i,b}$ [kN]	Opp. Bout [mm <sup>2</sup> ]	$\Delta \sigma_{i,b}$ [Mpa]	DC <sub>i,b</sub> [Mpa]	$\Delta \sigma_{c,i,b}$ [Mpa]	UC bout			
101	Main leg	130x130x12	4	M24	24.0	3000	2688	8.9	50	43	0.21	36.2	452	20.0	100	87	0.23			
102	Main leg	160x160x15	6	M24	36.6	4671	4281	8.6	50	43	0.20	53.5	452	19.7	100	87	0.23			
103	Main leg	160x160x15	8	M24	58.9	4671	4281	13.8	50	43	0.32	83.3	452	23.0	100	87	0.26			
104	Main leg	160x160x15	8	M24	80.3	4671	4281	18.8	50	43	0.43	114.4	452	31.6	100	87	0.36			
105	Main leg	250x250x24	8	M24	115.8	11492	10868	10.7	50	43	0.25	169.1	452	46.8	100	87	0.54			
106	Main leg	250x250x24	0		140.7	11492	11492	12.2	50	43	0.28	204.3	0	0.0	100	87	0.00			
107	Main leg	250x250x24	12	M24	152.8	11492	10868	14.1	50	43	0.32	217.1	452	40.0	100	87	0.46			
108	Main leg	200x200x24	24	M24	180.3	9060	8436	21.4	50	43	0.49	251.9	452	23.2	100	87	0.27			
109	Main leg	200x200x24	20	M24	196.8	9060	8436	23.3	50	43	0.54	273.1	452	30.2	100	87	0.35			
110	Main leg	250x250x24	24	M24	215.6	11492	10868	19.8	50	43	0.46	296.7	452	27.4	100	87	0.31			
111	Main leg	250x250x24	28	M24	226.4	11492	10868	20.8	50	43	0.48	308.1	452	24.3	100	87	0.28			
112.3	Main leg	250x250x24	28	M24	244.8	11492	10868	22.5	50	43	0.52	331.2	452	26.2	100	87	0.30			
113.3	Main leg	250x250x24	0		196.8	11492	11492	17.1	50	43	0.39	258.7	0	0.0	100	87	0.00			
114.3	Main leg	250x250x24	28	M24	196.4	11492	10868	18.1	50	43	0.42	258.2	452	20.4	100	87	0.23			
200	Diag front face	100x100x10	2	M24	18.6	1920	1660	11.2	50	43	0.26	28.2	452	31.2	100	87	0.36			
201	Diag front face	150x150x14	6	M24	106.9	4014	3650	29.3	50	43	0.67	161.3	452	59.5	100	87	0.68			
202	Diag front face	150x150x14	5	M24	89.4	4014	3650	24.5	50	43	0.56	135.0	452	59.7	100	87	0.69			
203	Diag front face	150x150x14	5	M24	78.3	4014	3650	21.5	50	43	0.49	118.0	452	52.2	100	87	0.60			
204	Diag front face	120x120x12(12,0,33)	4	M24	104.8	5500	5188	20.2	50	43	0.46	149.4	452	82.7	100	87	0.95			
205	Diag front face	120x120x12(12,0,33)	4	M24	91.0	5500	5188	17.5	50	43	0.40	129.9	452	71.8	100	87	0.83			
206	Diag front face	120x120x12(12,0,33)	4	M24	81.2	5500	5188	15.7	50	43	0.36	113.5	452	62.7	100	87	0.72			
207	Diag front face	120x120x12(12,0,33)	4	M24	78.4	5500	5188	15.1	50	43	0.35	103.8	452	57.4	100	87	0.66			
208	Diag front face	120x120x12(12,0,33)	4	M24	69.8	5500	5188	13.5	50	43	0.31	92.4	452	51.1	100	87	0.59			
209	Diag front face	120x120x12(12,0,33)	4	M24	65.1	5500	5188	12.6	50	43	0.29	85.7	452	47.4	100	87	0.55			
210	Diag front face	120x120x12(12,0,33)	4	M24	64.0	5500	5188	12.3	50	43	0.28	84.1	452	46.5	100	87	0.53			
211.3	Diag front face	150x150x12(15,0,33)	3	M24	42.5	6970	6658	6.4	50	43	0.15	56.3	452	41.5	100	87	0.48			
212.3	Diag front face	130x130x12#(15,0,33)	3	M24	31.6	6040	5728	5.5	50	43	0.13	41.9	452	30.9	100	87	0.36			
213.3	Diag front face	160x160x15#(14,0,33)	5	M24	33.3	9342	8952	3.7	50	43	0.09	44.1	452	19.5	100	87	0.22			
214.3	Diag front face	150x150x12(12,0,33)	4	M24	57.6	6970	6658	8.7	50	43	0.20	76.8	452	42.5	100	87	0.49			
300	Diag side face	80x80x8	2	M24	14.4	1230	1022	14.1	50	43	0.32	21.9	452	24.2	100	87	0.28			
301	Diag side face	150x150x14	6	M24	107.6	4014	3650	29.5	50	43	0.68	162.6	452	60.4	100	87	0.69			
302	Diag side face	150x150x14	5	M24	90.4	4014	3650	24.8	50	43	0.57	136.5	452	60.4	100	87	0.69			
303	Diag side face	150x150x14	4	M24	74.4	4014	3650	20.4	50	43	0.47	112.3	452	62.1	100	87	0.71			
304	Diag side face	120x120x12(12,0,33)	4	M24	96.4	5500	5188	18.6	50	43	0.43	133.7	452	74.0	100	87	0.85			

**Check galloping - 140gr**

Datum: 16-7-2021  
 Auteur: TBR  
 Versie: 1.0

RLI-TBG  
 HB+6/c

Group	Omschrijving	Profiel	Aantal bouten	Bout	Controle netto oppervlak profiel							Controle boutdoorsnede						
					$\Delta F_i$ [kN]	Brutto [mm <sup>2</sup> ]	Netto [mm <sup>2</sup> ]	$\Delta \sigma_i$ [Mpa]	DC <sub>i</sub> [Mpa]	$\Delta \sigma_{c,i}$ [Mpa]	UC opp.	$\Delta F_{i,b}$ [kN]	Opp. Bout [mm <sup>2</sup> ]	$\Delta \sigma_{i,b}$ [Mpa]	DC <sub>i,b</sub> [Mpa]	$\Delta \sigma_{c,i,b}$ [Mpa]	UC bout	
305	Diag side face	120x120x12(12,0,33)	4	M24	84.4	5500	5188	16.3	50	43	0.37	117.1	452	64.8	100	87	0.75	
306	Diag side face	120x120x12(12,0,33)	3	M24	76.8	5500	5188	14.8	50	43	0.34	106.2	452	78.3	100	87	0.90	
307	Diag side face	120x120x12(12,0,33)	4	M24	84.9	5500	5188	16.4	50	43	0.38	112.5	452	62.2	100	87	0.72	
308	Diag side face	120x120x12(12,0,33)	4	M24	77.9	5500	5188	15.0	50	43	0.35	103.3	452	57.1	100	87	0.66	
309	Diag side face	120x120x12(12,0,33)	4	M24	73.8	5500	5188	14.2	50	43	0.33	97.7	452	54.1	100	87	0.62	
310	Diag side face	120x120x12(12,0,33)	4	M24	69.5	5500	5188	13.4	50	43	0.31	92.0	452	50.9	100	87	0.59	
311.3	Diag side face	150x150x12(12,0,33)	3	M24	53.5	6970	6658	8.0	50	43	0.18	71.4	452	52.7	100	87	0.61	
312.3	Diag side face	130x130x12#(15,0,33)	3	M24	39.1	6040	5728	6.8	50	43	0.16	52.1	452	38.4	100	87	0.44	
313.3	Diag side face	160x160x15#(14,0,33)	5	M24	40.4	9342	8952	4.5	50	43	0.10	53.9	452	23.9	100	87	0.27	
400	Horizontal lower ca.	180x180x16	10	M24	72.4	5540	5124	14.1	50	43	0.32	110.2	452	24.4	100	87	0.28	
401	Lower chord lower ca.	150x150x14	10	M24	141.8	4014	3650	38.8	50	43	0.89	216.0	452	47.8	100	87	0.55	
402	Lower chord lower ca.	150x150x14	0		126.2	4014	4014	31.4	50	43	0.72	192.7	0	0.0	100	87	0.00	
403	Lower chord lower ca.	150x150x14	0		106.2	4014	4014	26.5	50	43	0.61	162.1	0	0.0	100	87	0.00	
404	Lower chord lower ca.	150x150x14	0		87.1	4014	4014	21.7	50	43	0.50	133.0	0	0.0	100	87	0.00	
405	Lower chord lower ca.	150x150x14	0		35.4	4014	4014	8.8	50	43	0.20	54.1	0	0.0	100	87	0.00	
406	Lower chord lower ca.	150x150x14	0		35.5	4014	4014	8.9	50	43	0.20	54.2	0	0.0	100	87	0.00	
407	Lower chord lower ca.	150x150x14	0		0.4	4014	4014	0.1	50	43	0.00	0.7	0	0.0	100	87	0.00	
410	Horizontal lower ca.	130x130x12	3	M24	20.6	3000	2688	7.7	50	43	0.18	31.1	452	22.9	100	87	0.26	
411	Horizontal lower ca.	150x150x14 (not couf)	2	M24	12.4	8028	7664	1.6	50	43	0.04	19.0	452	21.0	100	87	0.24	
412	Horizontal lower ca.	HEA140	0		0.8	3140	3140	0.2	50	43	0.01	1.0	0	0.0	100	87	0.00	
413	Horizontal lower ca.	150x150x18 (not couf)	2	M24	25.7	10200	9732	2.6	50	43	0.06	39.2	452	43.3	100	87	0.50	
414	Beam lower ca.	HEB220	0		1.8	9104	9104	0.2	50	43	0.00	2.8	0	0.0	100	87	0.00	
415	Horizontal lower ca.	UNP220	0		4.7	3740	3740	1.3	50	43	0.03	7.2	0	0.0	100	87	0.00	
426	Upper chord lower ca.	100x100x10	4	M24	12.8	1920	1660	7.7	50	43	0.18	19.3	452	10.7	100	87	0.12	
427	Upper chord lower ca.	100x100x10	0		11.5	1920	1920	6.0	50	43	0.14	17.3	0	0.0	100	87	0.00	
428	Upper chord lower ca.	100x100x10	0		11.9	1920	1920	6.2	50	43	0.14	18.0	0	0.0	100	87	0.00	
429	Upper chord lower ca.	100x100x10	0		12.8	1920	1920	6.7	50	43	0.15	19.3	0	0.0	100	87	0.00	
430	Upper chord lower ca.	100x100x10	4	M20	12.8	1920	1700	7.5	50	43	0.22	24.9	314	15.4	100	87	0.18	
431	Upper chord lower ca.	100x100x10	2	M20	16.5	1920	1700	9.7	50	43	0.22	24.9	314	39.7	100	87	0.46	
433	Stability bracing lower ca.	70x70x6	1	M16	0.2	810	702	0.3	50	43	0.01	0.3	201	1.3	100	87	0.01	
434	Hand rail	60x60x6	1	M16	0.1	690	582	0.2	50	43	0.00	0.2	201	0.8	100	87	0.01	
435	Hand rail	100x50x6	2	M16	0.0	870	762	0.0	50	43	0.00	0.0	201	0.0	100	87	0.00	
436	Hand rail	60x60x6	1	M16	0.0	690	582	0.1	50	43	0.00	0.1	201	0.4	100	87	0.00	
437	Stability bracing lower ca.	70x70x6	1	M16	0.6	810	702	0.8	50	43	0.02	0.8	201	4.1	100	87	0.05	



**Check galloping - 140gr**

Datum: 16-7-2021  
 Auteur: TBR  
 Versie: 1.0

RLL-TBG  
 HB+6/c

Group	Omschrijving	Profiel	Aantal bouten	Bout	Controle netto oppervlak profiel										Controle boutdoorsnede					
					$\Delta F_{i0}$ [kN]	Brutto [mm <sup>2</sup> ]	Netto [mm <sup>2</sup> ]	$\Delta \sigma_{i0}$ [Mpa]	DC <sub>i0</sub> [Mpa]	$\Delta \sigma_{c,i0}$ [Mpa]	$\Delta F_{i,b}$ [kN]	Opp. Bout [mm <sup>2</sup> ]	$\Delta \sigma_{c,i,b}$ [Mpa]	DC <sub>i,b</sub> [Mpa]	$\Delta \sigma_{c,i,b}$ [Mpa]	UC opp.	UC bout			
440	Vertical side face lower ca.	70x70x6	1	M16	2.0	810	702	2.8	50	50	43	3.0	201	14.8	100	87	0.17			
441	Vertical side face lower ca.	70x70x6	1	M16	2.7	810	702	3.9	50	43	43	0.09	4.1	201	20.6	100	87	0.24		
442	Vertical side face lower ca.	60x60x6	1	M16	3.5	690	582	6.0	50	43	43	0.14	5.3	201	26.3	100	87	0.30		
443	Vertical side face lower ca.	60x60x6	1	M16	0.2	690	582	0.4	50	43	43	0.01	0.4	201	1.9	100	87	0.02		
444	Vertical side face lower ca.	60x60x6	1	M16	9.8	690	582	16.8	50	43	43	0.39	14.9	201	74.3	100	87	0.85		
460	Diag side face lower ca.	80x80x6	2	M16	5.2	940	832	6.3	50	43	43	0.14	7.7	201	19.2	100	87	0.22		
461	Diag side face lower ca.	60x60x6	2	M16	3.5	690	582	6.1	50	43	43	0.14	5.4	201	13.4	100	87	0.15		
462	Diag side face lower ca.	60x60x6	2	M16	5.5	690	582	9.4	50	43	43	0.22	8.4	201	20.8	100	87	0.24		
463	Diag side face lower ca.	60x60x6	2	M16	7.6	690	582	13.0	50	43	43	0.30	11.5	201	28.7	100	87	0.33		
464	Diag side face lower ca.	60x60x6	2	M16	10.0	690	582	17.2	50	43	43	0.39	15.3	201	37.9	100	87	0.44		
465	Stability bracing lower ca.	90x90x9	1	M16	0.3	1539	1377	0.2	50	43	43	0.00	0.4	201	1.8	100	87	0.02		
475	Diag lower plane lower ca.	80x80x6	2	M20	12.7	940	808	15.7	50	43	43	0.36	17.8	314	28.3	100	87	0.33		
476	Diag lower plane lower ca.	80x80x8	2	M20	15.6	1230	1054	14.8	50	43	43	0.34	21.8	314	34.7	100	87	0.40		
477	Diag lower plane lower ca.	80x80x6	2	M20	11.2	940	808	13.8	50	43	43	0.32	16.7	314	26.5	100	87	0.31		
478	Diag lower plane lower ca.	80x80x6	2	M20	13.2	940	808	16.4	50	43	43	0.38	20.2	314	32.1	100	87	0.37		
479	Diag lower plane lower ca.	70x70x6	2	M20	14.4	810	678	21.2	50	43	43	0.49	22.0	314	35.0	100	87	0.40		
480	Diag lower plane lower ca.	70x70x6	2	M20	16.2	810	678	23.9	50	43	43	0.55	24.8	314	39.4	100	87	0.45		
481	Diag lower plane lower ca.	70x70x6	2	M20	18.5	810	678	27.3	50	43	43	0.63	28.3	314	45.0	100	87	0.52		
482	Diag lower plane lower ca.	70x70x6	2	M20	21.8	810	678	32.2	50	43	43	0.74	33.3	314	53.1	100	87	0.61		
483	Diag lower plane lower ca.	70x70x6	2	M20	24.9	810	678	36.8	50	43	43	0.85	38.1	314	60.6	100	87	0.70		
484	Diag lower plane lower ca.	70x70x6	2	M16	11.8	810	702	16.9	50	43	43	0.39	18.1	201	44.9	100	87	0.52		
485	Plan bracing lower ca.	120x120x10	3	M24	26.0	2320	2060	12.6	50	43	43	0.29	45.2	28.8	100	87	0.33			
486	Plan bracing lower ca.	120x120x10	4	M24	0.1	2320	2060	0.0	50	43	43	0.00	0.1	45.2	0.0	100	87	0.00		
500	Horizontal mid ca.	200x200x18	10	M24	124.1	6910	6442	19.3	50	43	43	0.44	188.4	452	41.7	100	87	0.48		
501	Lower chord mid ca.	180x180x18	10	M24	212.8	6190	5722	37.2	50	43	43	0.86	322.9	452	71.4	100	87	0.82		
502	Lower chord mid ca.	180x180x18	0	0	206.3	6190	6190	33.3	50	43	43	0.77	313.6	0	0.0	100	87	0.00		
503	Lower chord mid ca.	180x180x18	0	0	189.3	6190	6190	30.6	50	43	43	0.70	288.7	0	0.0	100	87	0.00		
504	Lower chord mid ca.	180x180x18	8	M24	167.1	6190	5722	29.2	50	43	43	0.67	255.1	452	70.5	100	87	0.81		
505	Lower chord mid ca.	160x160x15	8	M24	144.5	4671	4281	33.8	50	43	43	0.78	220.6	452	61.0	100	87	0.70		
506	Lower chord mid ca.	160x160x15	0	0	106.2	4671	4671	22.7	50	43	43	0.52	162.1	0	0.0	100	87	0.00		
507	Lower chord mid ca.	160x160x15	0	0	70.8	4671	4671	15.2	50	43	43	0.35	108.1	0	0.0	100	87	0.00		
508	Lower chord mid ca.	160x160x15	0	0	39.7	4671	4671	8.5	50	43	43	0.20	60.6	0	0.0	100	87	0.00		
509	Lower chord mid ca.	160x160x15	0	0	0.3	4671	4341	0.1	50	43	43	0.00	0.4	314	0.7	100	87	0.01		
511	Horizontal mid ca.	150x150x12	3	M24	37.5	3480	3168	11.8	50	43	43	0.27	57.1	452	42.1	100	87	0.48		



**Check galloping - 140gr**

Datum: 16-7-2021  
 Auteur: TBR  
 Versie: 1.0

RLL-TBG  
 HB+6/c

Group	Omschrijving	Profiel	Aantal bouten	Bout	Controle netto oppervlak profiel										Controle boutdoorsnede					
					$\Delta F;0$ [kN]	Brutto [mm <sup>2</sup> ]	Netto [mm <sup>2</sup> ]	$\Delta\sigma;0$ [Mpa]	DC;0 [Mpa]	$\Delta\sigma;c;0$ [Mpa]	$\Delta F;0$ [kN]	Brutto [mm <sup>2</sup> ]	Netto [mm <sup>2</sup> ]	$\Delta\sigma;0$ [Mpa]	DC;0 [Mpa]	$\Delta\sigma;c;0$ [Mpa]	Opp. [mm <sup>2</sup> ]	UC opp.	$\Delta F;b$ [kN]	Brutto [mm <sup>2</sup> ]
512	Beam mid ca.	150x150x14 (not coup)	2	M24	15.3	8028	7664	2.0	50	43	0.05	21.3	452	23.6	100	87	0.27			
513	Horizontal mid ca.	HEA140	0		0.3	3140	3140	0.1	50	43	0.00	0.5	0	0.0	100	87	0.00			
514	Beam mid ca.	150x150x18 (not coup)	2	M24	24.6	10200	9732	2.5	50	43	0.06	37.6	452	41.6	100	87	0.48			
515	Horizontal mid ca.	HEB220	0		2.4	9104	9104	0.3	50	43	0.01	3.6	0	0.0	100	87	0.00			
516	Beam mid ca.	UNP220	0		7.3	3740	3740	1.9	50	43	0.04	11.1	0	0.0	100	87	0.00			
526	Upper chord mid ca.	120x120x12	4	M24	30.0	2750	2438	12.3	50	43	0.28	45.4	452	25.1	100	87	0.29			
527	Upper chord mid ca.	120x120x12	0		30.3	2750	2750	11.0	50	43	0.25	45.9	0	0.0	100	87	0.00			
528	Upper chord mid ca.	120x120x12	6	M24	29.2	2750	2438	12.0	50	43	0.28	44.3	452	16.3	100	87	0.19			
529	Upper chord mid ca.	100x100x10	6	M24	27.1	1920	1660	16.3	50	43	0.38	41.2	452	15.2	100	87	0.17			
530	Upper chord mid ca.	100x100x10	0		25.5	1920	1920	13.3	50	43	0.31	38.8	0	0.0	100	87	0.00			
531	Upper chord mid ca.	100x100x10	0		23.8	1920	1920	12.4	50	43	0.29	36.2	0	0.0	100	87	0.00			
532	Upper chord mid ca.	100x100x10	4	M24	23.9	1920	1660	14.4	50	43	0.33	36.3	452	20.1	100	87	0.23			
533	Upper chord mid ca.	100x100x10	2	M24	26.4	1920	1660	15.9	50	43	0.37	40.1	452	44.4	100	87	0.51			
535	Stability bracing mid ca.	70x70x6	1	M16	0.4	810	702	0.5	50	43	0.01	0.5	201	2.6	100	87	0.03			
536	Hand rail	60x60x6	1	M16	0.1	690	582	0.1	50	43	0.00	0.1	201	0.6	100	87	0.01			
537	Hand rail	100x50x6	2	M16	0.0	870	762	0.0	50	43	0.00	0.0	201	0.0	100	87	0.00			
538	Hand rail	60x60x6	1	M16	0.0	690	582	0.1	50	43	0.00	0.0	201	0.2	100	87	0.00			
539	Stability bracing mid ca.	70x70x6	1	M16	1.1	810	702	1.6	50	43	0.04	1.5	201	7.6	100	87	0.09			
540	Vertical side face mid ca.	80x80x6	1	M16	3.0	940	832	3.6	50	43	0.08	4.2	201	21.1	100	87	0.24			
541	Vertical side face mid ca.	80x80x6	1	M16	2.9	940	832	3.5	50	43	0.08	4.2	201	21.1	100	87	0.24			
542	Vertical side face mid ca.	60x60x6	1	M16	1.5	690	582	2.6	50	43	0.06	2.3	201	11.6	100	87	0.13			
543	Vertical side face mid ca.	60x60x6	1	M16	2.2	690	582	3.8	50	43	0.09	3.4	201	17.0	100	87	0.20			
544	Vertical side face mid ca.	60x60x6	1	M16	2.6	690	582	4.4	50	43	0.10	3.9	201	19.6	100	87	0.23			
545	Vertical side face mid ca.	60x60x6	1	M16	0.4	690	582	0.7	50	43	0.02	0.6	201	3.0	100	87	0.03			
546	Vertical side face mid ca.	60x60x6	2	M16	11.6	690	582	19.9	50	43	0.46	17.7	201	44.0	100	87	0.51			
561	Diag side face mid ca.	80x80x6	2	M16	2.7	940	832	3.3	50	43	0.08	4.1	201	10.3	100	87	0.12			
562	Diag side face mid ca.	70x70x6	2	M16	4.5	810	702	6.5	50	43	0.15	6.4	201	16.0	100	87	0.18			
563	Diag side face mid ca.	60x60x6	2	M16	4.5	690	582	7.7	50	43	0.18	6.6	201	16.4	100	87	0.19			
564	Diag side face mid ca.	60x60x6	2	M16	2.7	690	582	4.7	50	43	0.11	4.1	201	10.3	100	87	0.12			
565	Diag side face mid ca.	60x60x6	3	M16	4.9	690	582	8.4	50	43	0.19	7.4	201	18.5	100	87	0.21			
566	Diag side face mid ca.	60x60x6	3	M16	5.9	690	582	10.2	50	43	0.23	9.1	201	15.0	100	87	0.17			
567	Diag side face mid ca.	70x70x6	1	M16	7.1	810	702	10.0	50	43	0.23	10.8	201	17.8	100	87	0.21			
567	Stability bracing mid ca.	70x70x6	1	M16	0.6	810	702	0.8	50	43	0.02	0.8	201	3.9	100	87	0.04			
575	Diag lower plane mid ca.	70x70x6	2	M20	10.4	810	678	15.3	50	43	0.35	14.4	314	23.0	100	87	0.26			



**Check galloping - 140gr**

Datum: 16-7-2021  
 Auteur: TBR  
 Versie: 1.0

RLL-TBG  
 HB+6/c

Group	Omschrijving	Profiel	Aantal bouten	Bout	Controle netto oppervlak profiel							Controle boutdoorsnede						
					$\Delta F_o$ [kN]	Brutto [mm <sup>2</sup> ]	Netto [mm <sup>2</sup> ]	$\Delta \sigma_{i,j}$ [Mpa]	DC <sub>i,o</sub> [Mpa]	$\Delta \sigma_{c,j,o}$ [Mpa]	$\Delta F_{i,j}$ [kN]	Opp. Bout [mm <sup>2</sup> ]	$\Delta \sigma_{i,j,b}$ [Mpa]	DC <sub>i,b</sub> [Mpa]	$\Delta \sigma_{c,j,b}$ [Mpa]	UC opp.	UC bout	
576	Diag lower plane mid ca.	70x70x6	2	M20	12.6	810	678	18.6	50	43	0.43	17.6	314	28.0	100	87	0.32	
577	Diag lower plane mid ca.	70x70x6	2	M20	13.3	810	678	19.7	50	43	0.45	18.6	314	29.6	100	87	0.34	
578	Diag lower plane mid ca.	70x70x6	2	M20	14.7	810	678	21.7	50	43	0.50	20.5	314	32.7	100	87	0.38	
579	Diag lower plane mid ca.	70x70x6	2	M20	15.3	810	678	22.5	50	43	0.52	21.3	314	33.9	100	87	0.39	
580	Diag lower plane mid ca.	70x70x6	2	M20	12.7	810	678	18.7	50	43	0.43	19.0	314	30.3	100	87	0.35	
581	Diag lower plane mid ca.	70x70x6	2	M20	14.8	810	678	21.8	50	43	0.50	22.6	314	36.0	100	87	0.41	
582	Diag lower plane mid ca.	70x70x6	2	M20	15.8	810	678	23.3	50	43	0.54	24.1	314	38.4	100	87	0.44	
583	Diag lower plane mid ca.	70x70x6	2	M20	18.1	810	678	26.7	50	43	0.61	27.6	314	43.9	100	87	0.51	
584	Diag lower plane mid ca.	70x70x6	2	M20	20.5	810	678	30.3	50	43	0.70	31.3	314	49.9	100	87	0.57	
585	Diag lower plane mid ca.	80x80x6	2	M20	24.9	940	808	30.8	50	43	0.71	38.0	314	60.5	100	87	0.70	
586	Diag lower plane mid ca.	80x80x6	2	M20	28.1	940	808	34.8	50	43	0.80	42.9	314	68.4	100	87	0.79	
587	Diag lower plane mid ca.	60x60x6	2	M16	11.5	690	582	19.8	50	43	0.46	17.6	201	43.8	100	87	0.50	
588	Plan bracing mid ca.	140x140x13	5	M24	89.2	3521	3163	28.0	50	43	0.64	135.8	452	60.1	100	87	0.69	
589	Plan bracing mid ca.	150x150x12	4	M24	57.2	3480	3168	18.0	50	43	0.42	87.0	452	48.1	100	87	0.55	
600	Horizontal top ca.	200x200x18	10	M24	138.1	6910	6442	21.4	50	43	0.49	208.8	452	46.2	100	87	0.53	
601	Lower chord top ca.	180x180x18	8	M24	180.8	6190	5722	31.6	50	43	0.73	275.8	452	76.3	100	87	0.88	
602	Lower chord top ca.	180x180x18	6	M24	151.1	6190	5722	26.4	50	43	0.61	230.6	452	85.0	100	87	0.98	
603	Lower chord top ca.	150x150x14	6	M24	117.8	4014	3650	32.3	50	43	0.74	179.8	452	66.3	100	87	0.76	
604	Lower chord top ca.	150x150x14	0		61.7	4014	4014	15.4	50	43	0.35	94.2	0	0.0	100	87	0.00	
605	Lower chord top ca.	150x150x14	2	M20	33.4	4014	3706	9.0	50	43	0.21	50.9	314	81.0	100	87	0.93	
606	Lower chord top ca.	150x150x14	2	M20	5.0	4014	3706	1.3	50	43	0.03	7.4	314	11.7	100	87	0.13	
608	Earth peak lower chord	80x80x8	2	M20	6.8	1230	1054	6.5	50	43	0.15	9.6	314	15.3	100	87	0.18	
609	Earth peak lower chord	80x80x8	2	M20	6.3	1230	1054	6.0	50	43	0.14	8.9	314	14.2	100	87	0.16	
610	Horizontal top ca.	130x130x12	3	M24	39.6	3000	2688	14.7	50	43	0.34	59.4	452	43.8	100	87	0.50	
611	Horizontal top ca.	150x150x14 (not couf)	2	M24	13.0	8028	7664	1.7	50	43	0.04	19.8	452	21.9	100	87	0.25	
612	Horizontal top ca.	HEA140	0		0.8	3140	3140	0.3	50	43	0.01	1.2	0	0.0	100	87	0.00	
613	Horizontal top ca.	150x150x18 (not couf)	2	M24	25.7	10200	9732	2.6	50	43	0.06	39.2	452	43.4	100	87	0.50	
614	Beam top ca.	HEB220	0		2.0	9104	9104	0.2	50	43	0.01	3.1	0	0.0	100	87	0.00	
615	Earth peak horizontal	60x60x6	1	M16	0.8	690	582	1.4	50	43	0.03	1.2	201	6.1	100	87	0.07	
616	Earth peak horizontal	60x60x6	1	M16	0.8	690	582	1.4	50	43	0.03	1.2	201	6.2	100	87	0.07	
617	Earth peak horizontal	60x60x6	1	M16	0.0	690	582	0.0	50	43	0.00	0.0	201	0.1	100	87	0.00	
618	Beam top ca.	UNP220	0		4.6	3740	3740	1.2	50	43	0.03	7.1	0	0.0	100	87	0.00	
626	Upper chord top ca.	120x120x12	4	M24	38.9	2750	2438	16.0	50	43	0.37	59.4	452	32.8	100	87	0.38	
627	Upper chord top ca.	100x100x10	3	M24	16.7	1920	1660	10.1	50	43	0.23	25.2	452	18.6	100	87	0.21	



**Check galloping - 140gr**

Datum: 16-7-2021  
 Auteur: TBR  
 Versie: 1.0

RLL-TBG  
 HB+6/c

Group	Omschrijving	Profiel	Aantal bouten	Bout	Controle netto oppervlak profiel							Controle boutdoorsnede						
					$\Delta F_o$ [kN]	Brutto [mm <sup>2</sup> ]	Netto [mm <sup>2</sup> ]	$\Delta\sigma_i$ [Mpa]	DC <sub>i,o</sub> [Mpa]	$\Delta\sigma_c$ [Mpa]	opp.	UC opp.	$\Delta F_o$ [kN]	Opp. Bout [mm <sup>2</sup> ]	$\Delta\sigma_i$ [Mpa]	DC <sub>i,b</sub> [Mpa]	$\Delta\sigma_c$ [Mpa]	UC bout
628	Upper chord top ca.	100x100x10	6	M24	16.0	1920	1660	9.6	50	43	0.22	24.3	452	8.9	100	87	0.10	
629	Upper chord top ca.	100x100x10	3	M24	16.0	1920	1660	9.6	50	43	0.22	24.3	452	18.0	100	87	0.21	
630	Earth peak upper chord	130x130x12	0		55.3	3000	3000	18.4	50	43	0.42	75.3	0	0.0	100	87	0.00	
631	Earth peak upper chord	130x130x12	4	M24	48.4	3000	2688	18.0	50	43	0.41	67.9	452	37.6	100	87	0.43	
632	Earth peak upper chord	120x120x10	4	M24	46.0	2320	2060	22.3	50	43	0.51	64.6	452	35.7	100	87	0.41	
633	Earth peak upper chord	120x120x10	0		40.3	2320	2320	17.4	50	43	0.40	56.6	0	0.0	100	87	0.00	
634	Earth peak upper chord	120x120x10	0		31.8	2320	2320	13.7	50	43	0.32	44.6	0	0.0	100	87	0.00	
635	Earth peak upper chord	120x120x10	2	M20	18.1	2320	2100	8.6	50	43	0.20	25.3	314	40.3	100	87	0.46	
637	Stability bracing top ca.	70x70x7	1	M16	8.6	940	814	10.6	50	43	0.24	13.0	201	64.8	100	87	0.75	
638	Earth peak horizontal	UNP160	2	M20	4.5	2400	2235	2.0	50	43	0.05	6.3	314	10.0	100	87	0.12	
640	Vertical side face top ca.	60x60x6	2	M16	3.7	690	582	6.4	50	43	0.15	5.4	201	13.4	100	87	0.15	
641	Vertical side face top ca.	60x60x6	2	M16	13.0	690	582	22.3	50	43	0.51	19.6	201	48.8	100	87	0.56	
642	Vertical side face top ca.	80x80x6	2	M16	3.0	940	832	3.6	50	43	0.08	4.5	201	11.3	100	87	0.13	
643	Vertical side face top ca.	80x80x6	1	M16	0.2	940	832	0.3	50	43	0.01	0.4	201	1.8	100	87	0.02	
644	Vertical side face top ca.	80x80x6	1	M16	6.8	940	832	8.1	50	43	0.19	10.3	201	51.4	100	87	0.59	
645	Vertical side face top ca.	80x80x8	1	M16	0.1	1230	1086	0.1	50	43	0.00	0.2	201	0.8	100	87	0.01	
646	Earth peak vertical side face	60x60x6	1	M16	0.2	690	582	0.4	50	43	0.01	0.3	201	1.6	100	87	0.02	
660	Diag side face top ca.	80x80x6	2	M16	5.5	940	832	6.6	50	43	0.15	7.6	201	18.9	100	87	0.22	
661	Diag side face top ca.	80x80x8	2	M20	5.2	1230	1054	4.9	50	43	0.11	7.8	314	12.5	100	87	0.14	
662	Diag side face top ca.	80x80x6	1	M16	7.1	940	808	8.7	50	43	0.20	10.7	314	17.0	100	87	0.20	
663	Earth peak diag side face	80x80x6	1	M16	0.2	940	832	0.2	50	43	0.01	0.3	201	1.3	100	87	0.02	
664	Stability bracing top ca.	80x80x8	2	M16	16.3	1230	1086	15.0	50	43	0.35	24.7	201	61.4	100	87	0.71	
673	Earth peak diag upper side	60x60x6	2	M16	7.5	690	582	12.9	50	43	0.30	10.6	201	26.3	100	87	0.30	
674	Earth peak diag upper side	60x60x6	2	M16	5.8	690	582	10.0	50	43	0.23	8.2	201	20.3	100	87	0.23	
675	Diag lower plane top ca.	70x70x6	2	M20	12.7	810	678	18.8	50	43	0.43	17.8	314	28.3	100	87	0.33	
676	Diag lower plane top ca.	70x70x6	2	M20	16.1	810	678	23.7	50	43	0.55	22.5	314	35.9	100	87	0.41	
677	Diag lower plane top ca.	70x70x6	2	M20	14.8	810	678	21.9	50	43	0.50	20.8	314	33.0	100	87	0.38	
678	Diag lower plane top ca.	70x70x6	2	M20	13.1	810	678	19.3	50	43	0.44	19.8	314	31.6	100	87	0.36	
679	Diag lower plane top ca.	70x70x6	2	M20	14.2	810	678	20.9	50	43	0.48	21.6	314	34.4	100	87	0.40	
680	Diag lower plane top ca.	70x70x6	2	M20	15.1	810	678	22.2	50	43	0.51	22.9	314	36.5	100	87	0.42	
681	Diag lower plane top ca.	70x70x6	2	M20	23.8	810	678	35.0	50	43	0.81	36.3	314	57.7	100	87	0.66	
682	Diag lower plane top ca.	70x70x6	2	M20	26.6	810	678	39.3	50	43	0.90	40.7	314	64.7	100	87	0.74	
683	Diag lower plane top ca.	80x80x6	2	M20	28.4	940	808	35.1	50	43	0.81	43.3	314	69.0	100	87	0.79	
684	Diag lower plane top ca.	80x80x6	2	M20	29.2	940	808	36.1	50	43	0.83	44.5	314	70.9	100	87	0.82	





**Check galloping - 140gr**

Datum: 16-7-2021  
 Auteur: TBR  
 Versie: 1.0

RLI-TBG  
 HB+6/c

Group	Omschrijving	Profiel	Aantal bouten	Bout	Controle netto oppervlak profiel										Controle boutdoorsnede				
					$\Delta F_i$ [kN]	Brutto [mm <sup>2</sup> ]	Netto [mm <sup>2</sup> ]	$\Delta \sigma_i$ [Mpa]	DC <sub>i</sub> [Mpa]	$\Delta \sigma_{c,i}$ [Mpa]	UC opp.	$\Delta F_j$ [kN]	Bout [mm <sup>2</sup> ]	Opp.	$\Delta \sigma_j$ [Mpa]	DC <sub>j</sub> [Mpa]	$\Delta \sigma_{c,j}$ [Mpa]	UC bout	
685	Diag lower plane top ca.	60x60x6	2	M16	11.3	690	582	19.4	50	50	43	0.45	17.2	201	42.9	100	87	0.49	
686	Earth peak diag lower plane	70x70x7	1	M16	0.4	940	814	0.5	50	50	43	0.01	0.6	201	2.9	100	87	0.03	
687	Earth peak diag lower plane	70x70x7	1	M16	2.4	940	814	3.0	50	50	43	0.07	3.6	201	17.9	100	87	0.21	
688	Earth peak diag upper plane	70x70x6	2	M16	8.1	810	702	11.5	50	50	43	0.27	12.1	201	30.1	100	87	0.35	
689	Earth peak diag upper plane	70x70x6	2	M16	8.9	810	702	12.7	50	50	43	0.29	13.3	201	33.1	100	87	0.38	
690	Earth peak diag upper plane	60x60x6	2	M16	9.6	690	582	16.5	50	50	43	0.38	14.4	201	35.8	100	87	0.41	
691	Earth peak diag upper plane	60x60x6	2	M16	10.6	690	582	18.3	50	50	43	0.42	15.9	201	39.6	100	87	0.46	
692	Earth peak diag upper plane	60x60x6	1	M16	2.3	690	582	3.9	50	50	43	0.09	3.2	201	15.8	100	87	0.18	
693	Earth peak diag upper plane	60x60x6	1	M16	2.5	690	582	4.2	50	50	43	0.10	3.5	201	17.3	100	87	0.20	
694	Earth peak diag upper plane	60x60x6	1	M16	2.8	690	582	4.7	50	50	43	0.11	3.9	201	19.3	100	87	0.22	
695	Earth peak diag upper plane	60x60x6	1	M16	3.1	690	582	5.4	50	50	43	0.12	4.4	201	22.0	100	87	0.25	
696	Earth peak diag upper plane	60x60x6	1	M16	3.8	690	582	6.5	50	50	43	0.15	5.3	201	26.3	100	87	0.30	
697	Earth peak diag upper plane	60x60x6	1	M16	4.6	690	582	7.9	50	50	43	0.18	6.4	201	31.9	100	87	0.37	
698	Plan bracing top ca.	150x150x12	4	M24	58.2	3480	3168	18.4	50	50	43	0.42	87.5	452	48.4	100	87	0.56	
699	Plan bracing top ca.	140x140x13	5	M24	95.7	3521	3183	30.1	50	50	43	0.69	143.5	452	63.5	100	87	0.73	
700.3	Hor. Plan bracing hip structu	100x100x8	0		1.2	1550	1550	0.8	50	50	43	0.02	1.6	0	0.0	100	87	0.00	
701.3	Hor. Plan bracing hip structu	100x100x8	0		0.3	1550	1550	0.2	50	50	43	0.00	0.4	0	0.0	100	87	0.00	
702.3	Hor. Plan bracing hip structu	100x100x8 (not coupl	0		0.0	3100	3100	0.0	50	50	43	0.00	0.0	0	0.0	100	87	0.00	
703.3	2nd plan bacing	150x150x12	0		61.4	3480	3480	17.7	50	50	43	0.41	81.0	0	0.0	100	87	0.00	
704	2nd plan bacing	90x90x8	2	M20	2.9	1390	1214	2.4	50	50	43	0.05	4.3	314	6.8	100	87	0.08	
705	2nd plan bacing	90x90x8 (not coupled)	2	M20	0.0	2780	2604	0.0	50	50	43	0.00	0.0	314	0.0	100	87	0.00	
710	Horizontal top of lower ca.	120x120x12	4	M24	12.4	2750	2438	5.1	50	50	43	0.12	17.7	452	9.8	100	87	0.11	
711	Horizontal top of lower ca.	120x120x10	2	M24	2.0	2320	2060	1.0	50	50	43	0.02	2.9	452	3.2	100	87	0.04	
712	Horizontal top of mid ca.	120x120x12	4	M24	12.4	2750	2438	5.1	50	50	43	0.12	17.0	452	9.4	100	87	0.11	
713	Horizontal top of mid ca.	120x120x10	2	M24	3.2	2320	2060	1.6	50	50	43	0.04	4.5	452	4.9	100	87	0.06	
714	Horizontal top of top ca.	120x120x12	4	M24	18.6	2750	2438	7.6	50	50	43	0.18	28.4	452	15.7	100	87	0.18	
715	Horizontal top of top ca.	100x100x10	2	M24	0.9	1920	1660	0.6	50	50	43	0.01	1.3	452	1.5	100	87	0.02	



**Check galloping - 160gr**

Datum: 16-7-2021  
 Auteur: TBR  
 Versie: 1.0

RLL-TBG  
 HB+6/c

Group	Omschrijving	Profiel	Aantal bouten	Bout	Controle netto oppervlak profiel										Controle boutdoorsnede					
					$\Delta F_i$ [kN]	Brutto [mm <sup>2</sup> ]	Netto [mm <sup>2</sup> ]	$\Delta \sigma_i$ [Mpa]	DC <sub>i</sub> [Mpa]	$\Delta \sigma_{c,i}$ [Mpa]	$\Delta F_j$ [kN]	Bout [mm <sup>2</sup> ]	$\Delta \sigma_j$ [Mpa]	DC <sub>j</sub> [Mpa]	$\Delta \sigma_{c,j}$ [Mpa]	UC opp. [kN]	Opp. Bout [mm <sup>2</sup> ]	$\Delta \sigma_j$ [Mpa]	DC <sub>j</sub> [Mpa]	$\Delta \sigma_{c,j}$ [Mpa]
101	Main leg	130x130x12	4	M24	24.4	3000	2688	9.1	50	43	0.21	36.8	452	20.4	100	87	0.23			
102	Main leg	160x160x15	6	M24	41.2	4671	4281	9.6	50	43	0.22	59.8	452	22.1	100	87	0.25			
103	Main leg	160x160x15	8	M24	59.7	4671	4281	13.9	50	43	0.32	88.4	452	24.4	100	87	0.28			
104	Main leg	160x160x15	8	M24	73.4	4671	4281	17.1	50	43	0.39	103.6	452	28.6	100	87	0.33			
105	Main leg	250x250x24	8	M24	104.5	11492	10868	9.6	50	43	0.22	152.4	452	42.1	100	87	0.48			
106	Main leg	250x250x24	0		127.0	11492	11492	11.1	50	43	0.25	184.4	0	0.0	100	87	0.00			
107	Main leg	250x250x24	12	M24	137.9	11492	10868	12.7	50	43	0.29	195.5	452	36.1	100	87	0.41			
108	Main leg	200x200x24	24	M24	162.9	9060	8436	19.3	50	43	0.44	227.1	452	20.9	100	87	0.24			
109	Main leg	200x200x24	20	M24	177.7	9060	8436	21.1	50	43	0.48	246.4	452	27.3	100	87	0.31			
110	Main leg	250x250x24	24	M24	194.6	11492	10868	17.9	50	43	0.41	267.6	452	24.7	100	87	0.28			
111	Main leg	250x250x24	28	M24	204.3	11492	10868	18.8	50	43	0.43	277.8	452	22.0	100	87	0.25			
112.3	Main leg	250x250x24	28	M24	220.9	11492	10868	20.3	50	43	0.47	298.7	452	23.6	100	87	0.27			
113.3	Main leg	250x250x24	0		177.7	11492	11492	15.5	50	43	0.36	233.5	0	0.0	100	87	0.00			
114.3	Main leg	250x250x24	28	M24	177.4	11492	10868	16.3	50	43	0.38	233.1	452	18.4	100	87	0.21			
200	Diag front face	100x100x10	2	M24	19.0	1920	1660	11.4	50	43	0.26	28.9	452	31.9	100	87	0.37			
201	Diag front face	150x150x14	6	M24	106.1	4014	3650	29.1	50	43	0.67	160.1	452	59.0	100	87	0.68			
202	Diag front face	150x150x14	5	M24	88.8	4014	3650	24.3	50	43	0.56	133.9	452	59.2	100	87	0.68			
203	Diag front face	150x150x14	5	M24	78.2	4014	3650	21.4	50	43	0.49	117.9	452	52.2	100	87	0.60			
204	Diag front face	120x120x12(12,0,33)	4	M24	104.6	5500	5188	20.2	50	43	0.46	149.4	452	82.6	100	87	0.95			
205	Diag front face	120x120x12(12,0,33)	4	M24	90.9	5500	5188	17.5	50	43	0.40	129.9	452	71.8	100	87	0.83			
206	Diag front face	120x120x12(12,0,33)	4	M24	81.2	5500	5188	15.6	50	43	0.36	113.5	452	62.8	100	87	0.72			
207	Diag front face	120x120x12(12,0,33)	4	M24	77.2	5500	5188	14.9	50	43	0.34	102.2	452	56.5	100	87	0.65			
208	Diag front face	120x120x12(12,0,33)	4	M24	68.7	5500	5188	13.2	50	43	0.30	91.0	452	50.3	100	87	0.58			
209	Diag front face	120x120x12(12,0,33)	4	M24	64.4	5500	5188	12.4	50	43	0.29	84.9	452	47.0	100	87	0.54			
210	Diag front face	120x120x12(12,0,33)	4	M24	63.5	5500	5188	12.2	50	43	0.28	83.6	452	46.3	100	87	0.53			
211.3	Diag front face	150x150x12(12,0,33)	3	M24	43.5	6970	6658	6.5	50	43	0.15	57.8	452	42.6	100	87	0.49			
212.3	Diag front face	130x130x12#(15,0,33)	3	M24	32.3	6040	5728	5.6	50	43	0.13	42.9	452	31.6	100	87	0.36			
213.3	Diag front face	160x160x15#(14,0,33)	5	M24	34.3	9342	8952	3.8	50	43	0.09	45.6	452	20.2	100	87	0.23			
214.3	Diag front face	150x150x12(12,0,33)	4	M24	61.4	6970	6658	9.2	50	43	0.21	81.6	452	45.1	100	87	0.52			
300	Diag side face	80x80x8	2	M24	14.8	1230	1022	14.5	50	43	0.33	22.5	452	24.9	100	87	0.29			
301	Diag side face	150x150x14	6	M24	111.0	4014	3650	30.4	50	43	0.70	167.7	452	61.8	100	87	0.71			
302	Diag side face	150x150x14	5	M24	93.1	4014	3650	25.5	50	43	0.59	140.8	452	62.3	100	87	0.72			
303	Diag side face	150x150x14	4	M24	75.9	4014	3650	20.8	50	43	0.48	114.7	452	63.4	100	87	0.73			
304	Diag side face	120x120x12(12,0,33)	4	M24	100.3	5500	5188	19.3	50	43	0.44	139.2	452	77.0	100	87	0.89			



**Check galloping - 160gr**

Datum: 16-7-2021  
 Auteur: TBR  
 Versie: 1.0

RLI-TBG  
 HB+6/c

Group	Omschrijving	Profiel	Aantal bouten	Bout	Controle netto oppervlak profiel										Controle boutdoorsnede					
					$\Delta F_{i0}$ [kN]	Brutto [mm <sup>2</sup> ]	Netto [mm <sup>2</sup> ]	$\Delta \sigma_{i0}$ [Mpa]	DC <sub>i0</sub> [Mpa]	$\Delta \sigma_{c,i0}$ [Mpa]	UC opp. [kN]	AF <sub>i,b</sub> Bout [mm <sup>2</sup> ]	$\Delta \sigma_{i,b}$ [Mpa]	DC <sub>i,b</sub> [Mpa]	$\Delta \sigma_{c,i,b}$ [Mpa]	UC bout				
305	Diag side face	120x120x12(12,0,33)	4	M24	87.8	5500	5188	16.9	50	43	0.39	121.9	452	67.4	100	87	0.78			
306	Diag side face	120x120x12(12,0,33)	3	M24	78.6	5500	5188	15.1	50	43	0.35	109.2	452	80.5	100	87	0.93			
307	Diag side face	120x120x12(12,0,33)	4	M24	88.2	5500	5188	17.0	50	43	0.39	117.0	452	64.7	100	87	0.74			
308	Diag side face	120x120x12(12,0,33)	4	M24	80.8	5500	5188	15.6	50	43	0.36	107.2	452	59.3	100	87	0.68			
309	Diag side face	120x120x12(12,0,33)	4	M24	76.2	5500	5188	14.7	50	43	0.34	101.0	452	55.9	100	87	0.64			
310	Diag side face	120x120x12(12,0,33)	4	M24	71.3	5500	5188	13.8	50	43	0.32	94.7	452	52.4	100	87	0.60			
311.3	Diag side face	150x150x12(12,0,33)	3	M24	55.5	6970	6658	8.3	50	43	0.19	74.2	452	54.7	100	87	0.63			
312.3	Diag side face	130x130x12#(15,0,33)	3	M24	40.3	6040	5728	7.0	50	43	0.16	53.9	452	39.7	100	87	0.46			
313.3	Diag side face	160x160x15#(14,0,33)	5	M24	41.7	9342	8952	4.7	50	43	0.11	55.8	452	24.7	100	87	0.28			
400	Horizontal lower ca.	180x180x16	10	M24	72.2	5540	5124	14.1	50	43	0.32	110.0	452	24.3	100	87	0.28			
401	Lower chord lower ca.	150x150x14	10	M24	139.9	4014	3650	38.3	50	43	0.88	213.3	452	47.2	100	87	0.54			
402	Lower chord lower ca.	150x150x14	0		123.5	4014	4014	30.8	50	43	0.71	188.5	0	0.0	100	87	0.00			
403	Lower chord lower ca.	150x150x14	0		101.8	4014	4014	25.4	50	43	0.58	155.4	0	0.0	100	87	0.00			
404	Lower chord lower ca.	150x150x14	0		81.7	4014	4014	20.4	50	43	0.47	124.8	0	0.0	100	87	0.00			
405	Lower chord lower ca.	150x150x14	0		27.3	4014	4014	6.8	50	43	0.16	41.7	0	0.0	100	87	0.00			
406	Lower chord lower ca.	150x150x14	0		27.4	4014	4014	6.8	50	43	0.16	41.8	0	0.0	100	87	0.00			
407	Lower chord lower ca.	150x150x14	0		0.5	4014	4014	0.1	50	43	0.00	0.7	0	0.0	100	87	0.00			
410	Horizontal lower ca.	130x130x12	3	M24	20.6	3000	2688	7.7	50	43	0.18	31.1	452	22.9	100	87	0.26			
411	Horizontal lower ca.	150x150x14 (not coup)	2	M24	13.4	8028	7664	1.8	50	43	0.04	20.5	452	22.7	100	87	0.26			
412	Horizontal lower ca.	HEA140	0		0.7	3140	3140	0.2	50	43	0.01	1.0	0	0.0	100	87	0.00			
413	Horizontal lower ca.	150x150x18 (not coup)	2	M24	27.7	10200	9732	2.8	50	43	0.07	42.3	452	46.8	100	87	0.54			
414	Beam lower ca.	HEB220	0		2.0	9104	9104	0.2	50	43	0.01	3.1	0	0.0	100	87	0.00			
415	Horizontal lower ca.	UNP220	0		5.0	3740	3740	1.3	50	43	0.03	7.7	0	0.0	100	87	0.00			
426	Upper chord lower ca.	100x100x10	4	M24	12.6	1920	1660	7.6	50	43	0.17	19.1	452	10.6	100	87	0.12			
427	Upper chord lower ca.	100x100x10	0		11.5	1920	1920	6.0	50	43	0.14	17.4	0	0.0	100	87	0.00			
428	Upper chord lower ca.	100x100x10	0		11.9	1920	1920	6.2	50	43	0.14	18.0	0	0.0	100	87	0.00			
429	Upper chord lower ca.	100x100x10	0		12.8	1920	1920	6.7	50	43	0.15	19.3	0	0.0	100	87	0.00			
430	Upper chord lower ca.	100x100x10	4	M20	12.8	1920	1700	7.6	50	43	0.17	19.4	314	15.4	100	87	0.18			
431	Upper chord lower ca.	100x100x10	2	M20	16.5	1920	1700	9.7	50	43	0.22	25.0	314	39.7	100	87	0.46			
433	Stability bracing lower ca.	70x70x6	1	M16	0.2	810	702	0.3	50	43	0.01	0.3	201	1.3	100	87	0.02			
434	Hand rail	60x60x6	1	M16	0.1	690	582	0.2	50	43	0.00	0.2	201	0.8	100	87	0.01			
435	Hand rail	100x50x6	2	M16	0.0	870	762	0.0	50	43	0.00	0.0	201	0.0	100	87	0.00			
436	Hand rail	60x60x6	1	M16	0.0	690	582	0.1	50	43	0.00	0.1	201	0.4	100	87	0.00			
437	Stability bracing lower ca.	70x70x6	1	M16	0.6	810	702	0.8	50	43	0.02	0.9	201	4.3	100	87	0.05			



**Check galloping - 160gr**

Datum: 16-7-2021  
 Auteur: TBR  
 Versie: 1.0

RLL-TBG  
 HB+6/c

Group	Omschrijving	Profiel	Aantal bouten	Bout	Controle netto oppervlak profiel										Controle boutdoorsnede					
					$\Delta F_o$ [kN]	Brutto [mm <sup>2</sup> ]	Netto [mm <sup>2</sup> ]	$\Delta \sigma_i$ [Mpa]	DC <sub>i</sub> [Mpa]	$\Delta \sigma_c$ [Mpa]	DC <sub>c</sub> [Mpa]	opp. [Mpa]	UC opp.	$\Delta F_b$ [kN]	Bout [mm <sup>2</sup> ]	$\Delta \sigma_i$ [Mpa]	DC <sub>i</sub> [Mpa]	$\Delta \sigma_c$ [Mpa]	UC bout	
440	Vertical side face lower ca.	70x70x6	1	M16	1.9	810	702	2.8	50	50	43	0.06	3.0	201	14.8	100	87	0.17		
441	Vertical side face lower ca.	70x70x6	1	M16	2.7	810	702	3.9	50	50	43	0.09	4.1	201	20.5	100	87	0.24		
442	Vertical side face lower ca.	60x60x6	1	M16	3.5	690	582	5.9	50	50	43	0.14	5.3	201	26.3	100	87	0.30		
443	Vertical side face lower ca.	60x60x6	1	M16	0.2	690	582	0.4	50	50	43	0.01	0.3	201	1.7	100	87	0.02		
444	Vertical side face lower ca.	60x60x6	1	M16	9.6	690	582	16.5	50	50	43	0.38	14.7	201	72.9	100	87	0.84		
460	Diag side face lower ca.	80x80x6	2	M16	5.2	940	832	6.3	50	50	43	0.14	7.7	201	19.3	100	87	0.22		
461	Diag side face lower ca.	60x60x6	2	M16	3.5	690	582	6.1	50	50	43	0.14	5.4	201	13.4	100	87	0.15		
462	Diag side face lower ca.	60x60x6	2	M16	5.4	690	582	9.4	50	50	43	0.22	8.3	201	20.7	100	87	0.24		
463	Diag side face lower ca.	60x60x6	2	M16	7.5	690	582	13.0	50	50	43	0.30	11.5	201	28.7	100	87	0.33		
464	Diag side face lower ca.	60x60x6	2	M16	9.8	690	582	16.8	50	50	43	0.39	14.9	201	37.1	100	87	0.43		
465	Stability bracing lower ca.	90x90x9	1	M16	0.3	1539	1377	0.2	50	50	43	0.00	0.4	201	1.9	100	87	0.02		
475	Diag lower plane lower ca.	80x80x6	2	M20	13.8	940	808	17.0	50	50	43	0.39	19.3	314	30.7	100	87	0.35		
476	Diag lower plane lower ca.	80x80x8	2	M20	16.8	1230	1054	16.0	50	50	43	0.37	23.5	314	37.4	100	87	0.43		
477	Diag lower plane lower ca.	80x80x6	2	M20	11.9	940	808	14.7	50	50	43	0.34	17.7	314	28.2	100	87	0.32		
478	Diag lower plane lower ca.	80x80x6	2	M20	14.1	940	808	17.5	50	50	43	0.40	21.6	314	34.3	100	87	0.39		
479	Diag lower plane lower ca.	70x70x6	2	M20	15.5	810	678	22.8	50	50	43	0.53	23.6	314	37.7	100	87	0.43		
480	Diag lower plane lower ca.	70x70x6	2	M20	17.5	810	678	25.8	50	50	43	0.59	26.7	314	42.6	100	87	0.49		
481	Diag lower plane lower ca.	70x70x6	2	M20	20.0	810	678	29.5	50	50	43	0.68	30.5	314	48.6	100	87	0.56		
482	Diag lower plane lower ca.	70x70x6	2	M20	23.6	810	678	34.8	50	50	43	0.80	36.0	314	57.4	100	87	0.66		
483	Diag lower plane lower ca.	70x70x6	2	M20	26.8	810	678	39.5	50	50	43	0.91	40.9	314	65.1	100	87	0.75		
484	Diag lower plane lower ca.	70x70x6	2	M16	12.8	810	702	18.2	50	50	43	0.42	19.5	201	48.6	100	87	0.56		
485	Plan bracing lower ca.	120x120x10	3	M24	26.6	2320	2060	12.9	50	50	43	0.30	40.0	452	29.5	100	87	0.34		
486	Plan bracing lower ca.	120x120x10	4	M24	0.0	2320	2060	0.0	50	50	43	0.00	0.1	452	0.0	100	87	0.00		
500	Horizontal mid ca.	200x200x18	10	M24	126.1	6910	6442	19.6	50	50	43	0.45	191.6	452	42.4	100	87	0.49		
501	Lower chord mid ca.	180x180x18	10	M24	214.6	6190	5722	37.5	50	50	43	0.86	325.9	452	72.1	100	87	0.83		
502	Lower chord mid ca.	180x180x18	0	0	207.7	6190	6190	33.6	50	50	43	0.77	316.0	0	0.0	100	87	0.00		
503	Lower chord mid ca.	180x180x18	0	0	189.9	6190	6190	30.7	50	50	43	0.71	289.6	0	0.0	100	87	0.00		
504	Lower chord mid ca.	180x180x18	8	M24	166.4	6190	5722	29.1	50	50	43	0.76	254.0	452	70.2	100	87	0.81		
505	Lower chord mid ca.	160x160x15	8	M24	142.4	4671	4281	33.3	50	50	43	0.76	217.4	452	60.1	100	87	0.69		
506	Lower chord mid ca.	160x160x15	0	0	101.8	4671	4671	21.8	50	50	43	0.50	155.4	0	0.0	100	87	0.00		
507	Lower chord mid ca.	160x160x15	0	0	65.0	4671	4671	13.9	50	50	43	0.32	99.2	0	0.0	100	87	0.00		
508	Lower chord mid ca.	160x160x15	0	0	32.0	4671	4671	6.8	50	50	43	0.16	48.8	0	0.0	100	87	0.00		
509	Lower chord mid ca.	160x160x15	2	M20	0.3	4671	4341	0.1	50	50	43	0.00	0.5	314	0.7	100	87	0.01		
511	Horizontal mid ca.	150x150x12	3	M24	38.4	3480	3168	12.1	50	50	43	0.28	58.4	452	43.1	100	87	0.50		

### Check galloping - 160gr

Datum: 16-7-2021  
 Auteur: TBR  
 Versie: 1.0

RLL-TBG  
 HB+6/c

Group	Omschrijving	Profiel	Aantal bouten	Bout	Controle netto oppervlak profiel										Controle boutdoorsnede					
					$\Delta F_i$ [kN]	Brutto [mm <sup>2</sup> ]	Netto [mm <sup>2</sup> ]	$\Delta \sigma_i$ [Mpa]	DC <sub>i</sub> [Mpa]	$\Delta \sigma_{c,i}$ [Mpa]	UC opp. [Mpa]	$\Delta F_{i,b}$ [kN]	Bout [mm <sup>2</sup> ]	Opp. [mm <sup>2</sup> ]	$\Delta \sigma_{i,b}$ [Mpa]	DC <sub>i,b</sub> [Mpa]	$\Delta \sigma_{c,i,b}$ [Mpa]	UC bout		
512	Beam mid ca.	150x150x14 (not coup)	2	M24	16.3	8028	7664	2.1	50	43	0.05	22.8	452	25.2	100	87	0.29			
513	Horizontaal mid ca.	HEA140	0		0.3	3140	3140	0.1	50	43	0.00	0.4	0	0.0	100	87	0.00			
514	Beam mid ca.	150x150x18 (not coup)	2	M24	26.4	10200	9732	2.7	50	43	0.06	40.2	452	44.5	100	87	0.51			
515	Horizontaal mid ca.	HEB220	0		2.6	9104	9104	0.3	50	43	0.01	4.0	0	0.0	100	87	0.00			
516	Beam mid ca.	UNP220	0		7.6	3740	3740	2.0	50	43	0.05	11.6	0	0.0	100	87	0.00			
526	Upper chord mid ca.	120x120x12	4	M24	30.6	2750	2438	12.6	50	43	0.29	46.4	452	25.7	100	87	0.29			
527	Upper chord mid ca.	120x120x12	0		30.9	2750	2750	11.2	50	43	0.26	46.9	0	0.0	100	87	0.00			
528	Upper chord mid ca.	120x120x12	6	M24	29.8	2750	2438	12.2	50	43	0.28	45.2	452	16.7	100	87	0.19			
529	Upper chord mid ca.	100x100x10	6	M24	27.6	1920	1660	13.5	50	43	0.38	41.9	452	15.5	100	87	0.18			
530	Upper chord mid ca.	100x100x10	0		26.0	1920	1920	16.6	50	43	0.31	39.5	0	0.0	100	87	0.00			
531	Upper chord mid ca.	100x100x10	0		24.2	1920	1920	12.6	50	43	0.29	36.8	0	0.0	100	87	0.00			
532	Upper chord mid ca.	100x100x10	4	M24	24.2	1920	1660	14.6	50	43	0.34	40.7	452	20.4	100	87	0.23			
533	Upper chord mid ca.	100x100x10	2	M24	26.8	1920	1660	16.1	50	43	0.37	40.7	452	45.0	100	87	0.52			
535	Stability bracing mid ca.	70x70x6	1	M16	0.4	810	702	0.6	50	43	0.01	0.5	201	2.7	100	87	0.03			
536	Hand rail	60x60x6	1	M16	0.1	690	582	0.1	50	43	0.00	0.1	201	0.6	100	87	0.01			
537	Hand rail	100x50x6	2	M16	0.0	870	762	0.0	50	43	0.00	0.0	201	0.0	100	87	0.00			
538	Hand rail	60x60x6	1	M16	0.0	690	582	0.1	50	43	0.00	0.1	201	0.3	100	87	0.00			
539	Stability bracing mid ca.	70x70x6	1	M16	1.1	810	702	1.6	50	43	0.04	1.6	201	7.9	100	87	0.09			
540	Vertical side face mid ca.	80x80x6	1	M16	3.0	940	832	3.6	50	43	0.08	4.2	201	21.1	100	87	0.24			
541	Vertical side face mid ca.	80x80x6	1	M16	2.9	940	832	3.5	50	43	0.08	4.2	201	21.1	100	87	0.24			
542	Vertical side face mid ca.	60x60x6	1	M16	1.5	690	582	2.6	50	43	0.06	2.3	201	11.4	100	87	0.13			
543	Vertical side face mid ca.	60x60x6	1	M16	2.2	690	582	3.8	50	43	0.09	3.4	201	16.8	100	87	0.19			
544	Vertical side face mid ca.	60x60x6	1	M16	2.5	690	582	4.4	50	43	0.10	3.9	201	19.3	100	87	0.22			
545	Vertical side face mid ca.	60x60x6	1	M16	0.4	690	582	0.7	50	43	0.02	0.6	201	2.9	100	87	0.03			
546	Vertical side face mid ca.	60x60x6	2	M16	11.5	690	582	19.8	50	43	0.45	17.6	201	43.7	100	87	0.50			
561	Diag side face mid ca.	70x70x6	2	M16	2.7	940	832	3.3	50	43	0.08	4.1	201	10.3	100	87	0.12			
562	Diag side face mid ca.	60x60x6	2	M16	4.5	810	702	6.5	50	43	0.15	6.4	201	15.9	100	87	0.18			
563	Diag side face mid ca.	60x60x6	2	M16	4.5	690	582	7.7	50	43	0.18	6.6	201	16.3	100	87	0.19			
564	Diag side face mid ca.	60x60x6	2	M16	2.7	690	582	4.6	50	43	0.11	4.1	201	10.1	100	87	0.12			
565	Diag side face mid ca.	60x60x6	3	M16	4.8	690	582	8.3	50	43	0.19	7.3	201	18.3	100	87	0.21			
566	Diag side face mid ca.	60x60x6	3	M16	5.9	690	582	10.1	50	43	0.23	8.9	201	14.8	100	87	0.17			
567	Stability bracing mid ca.	70x70x6	1	M16	6.8	810	702	9.6	50	43	0.22	10.3	201	17.1	100	87	0.20			
575	Diag lower plane mid ca.	70x70x6	2	M20	11.1	810	678	16.3	50	43	0.02	0.8	201	4.0	100	87	0.05			



**Check galloping - 160gr**

Datum: 16-7-2021  
 Auteur: TBR  
 Versie: 1.0

RLL-TBG  
 HB+6/c

Group	Omschrijving	Profiel	Aantal bouten	Bout	Controle netto oppervlak profiel						Controle boutdoorsnede						
					$\Delta F_i$ [kN]	Brutto [mm <sup>2</sup> ]	Netto [mm <sup>2</sup> ]	$\Delta \sigma_i$ [Mpa]	DC <sub>i</sub> [Mpa]	$\Delta \sigma_{c,i}$ [Mpa]	UC opp. [kN]	DF <sub>i</sub> b [kN]	Bout [mm <sup>2</sup> ]	$\Delta \sigma_{i,b}$ [Mpa]	DC <sub>i</sub> b [Mpa]	$\Delta \sigma_{c,i,b}$ [Mpa]	UC bout
576	Diag lower plane mid ca.	70x70x6	2	M20	13.5	810	678	19.9	50	43	0.46	18.8	314	29.9	100	87	0.34
577	Diag lower plane mid ca.	70x70x6	2	M20	14.2	810	678	21.0	50	43	0.48	19.9	314	31.6	100	87	0.36
578	Diag lower plane mid ca.	70x70x6	2	M20	15.7	810	678	23.2	50	43	0.53	22.0	314	35.0	100	87	0.40
579	Diag lower plane mid ca.	70x70x6	2	M20	16.3	810	678	24.0	50	43	0.55	22.7	314	36.1	100	87	0.42
580	Diag lower plane mid ca.	70x70x6	2	M20	13.5	810	678	19.9	50	43	0.46	20.1	314	32.1	100	87	0.37
581	Diag lower plane mid ca.	70x70x6	2	M20	15.8	810	678	23.3	50	43	0.53	24.1	314	38.3	100	87	0.44
582	Diag lower plane mid ca.	70x70x6	2	M20	16.9	810	678	24.9	50	43	0.57	25.7	314	41.0	100	87	0.47
583	Diag lower plane mid ca.	70x70x6	2	M20	19.3	810	678	28.4	50	43	0.65	29.4	314	46.9	100	87	0.54
584	Diag lower plane mid ca.	70x70x6	2	M20	21.9	810	678	32.3	50	43	0.74	33.4	314	53.3	100	87	0.61
585	Diag lower plane mid ca.	80x80x6	2	M20	26.6	940	808	33.0	50	43	0.76	40.7	314	64.8	100	87	0.74
586	Diag lower plane mid ca.	80x80x6	2	M20	29.8	940	808	36.9	50	43	0.85	45.5	314	72.5	100	87	0.83
587	Diag lower plane mid ca.	60x60x6	2	M16	12.3	690	582	21.1	50	43	0.49	18.8	201	46.7	100	87	0.54
588	Plan bracing mid ca.	140x140x13	5	M24	92.5	3521	3163	29.1	50	43	0.67	140.8	452	62.3	100	87	0.72
589	Plan bracing mid ca.	150x150x12	4	M24	59.3	3480	3168	18.7	50	43	0.43	90.2	452	49.9	100	87	0.57
600	Horizontal top ca.	200x200x18	10	M24	139.4	6910	6442	21.6	50	43	0.50	210.7	452	46.6	100	87	0.54
601	Lower chord top ca.	180x180x18	8	M24	180.5	6190	5722	31.5	50	43	0.73	275.3	452	76.1	100	87	0.88
602	Lower chord top ca.	180x180x18	6	M24	149.0	6190	5722	26.0	50	43	0.60	227.5	452	83.9	100	87	0.96
603	Lower chord top ca.	150x150x14	6	M24	113.8	4014	3650	31.2	50	43	0.72	173.6	452	64.0	100	87	0.74
604	Lower chord top ca.	150x150x14	0		55.0	4014	4014	13.7	50	43	0.32	83.9	0	0.0	100	87	0.00
605	Lower chord top ca.	150x150x14	2	M20	25.3	4014	3706	6.8	50	43	0.16	38.3	314	61.0	100	87	0.70
606	Lower chord top ca.	150x150x14	2	M20	5.2	4014	3706	1.4	50	43	0.03	7.4	314	11.7	100	87	0.13
608	Earth peak lower chord	80x80x8	2	M20	6.7	1230	1054	6.4	50	43	0.15	9.6	314	15.2	100	87	0.18
609	Earth peak lower chord	80x80x8	2	M20	5.6	1230	1054	5.3	50	43	0.12	7.9	314	12.5	100	87	0.14
610	Horizontal top ca.	130x130x12	3	M24	40.9	3000	2688	15.2	50	43	0.35	61.1	452	45.1	100	87	0.52
611	Horizontal top ca.	150x150x14 (not couf)	2	M24	13.7	8028	7664	1.8	50	43	0.04	21.0	452	23.2	100	87	0.27
612	Horizontal top ca.	HEA140	0		0.8	3140	3140	0.2	50	43	0.01	1.1	0	0.0	100	87	0.00
613	Horizontal top ca.	150x150x18 (not couf)	2	M24	27.1	10200	9732	2.8	50	43	0.06	41.4	452	45.8	100	87	0.53
614	Beam top ca.	HEB220	0		2.2	9104	9104	0.2	50	43	0.01	3.3	0	0.0	100	87	0.00
615	Earth peak horizontal	60x60x6	1	M16	0.8	690	582	1.4	50	43	0.03	1.2	201	6.1	100	87	0.07
616	Earth peak horizontal	60x60x6	1	M16	0.8	690	582	1.4	50	43	0.03	1.2	201	6.2	100	87	0.07
617	Earth peak horizontal	60x60x6	1	M16	0.0	690	582	0.0	50	43	0.00	0.0	201	0.1	100	87	0.00
618	Beam top ca.	UNP220	0		4.9	3740	3740	1.3	50	43	0.03	7.5	0	0.0	100	87	0.00
626	Upper chord top ca.	120x120x12	4	M24	39.8	2750	2438	16.3	50	43	0.38	60.7	452	33.6	100	87	0.39
627	Upper chord top ca.	100x100x10	3	M24	16.6	1920	1660	10.0	50	43	0.23	25.1	452	18.5	100	87	0.21



**Check galloping - 160gr**

Datum: 16-7-2021  
 Auteur: TBR  
 Versie: 1.0

RLI-TBG  
 HB+6/c

Group	Omschrijving	Profiel	Aantal bouten	Bout	Controle netto oppervlak profiel										Controle boutdoorsnede					
					$\Delta F_i$ [kN]	Brutto [mm <sup>2</sup> ]	Netto [mm <sup>2</sup> ]	$\Delta \sigma_i$ [Mpa]	DC <sub>i</sub> [Mpa]	$\Delta \sigma_{c,i}$ [Mpa]	$\Delta F_j$ [kN]	Bout [mm <sup>2</sup> ]	$\Delta \sigma_j$ [Mpa]	DC <sub>j</sub> [Mpa]	$\Delta \sigma_{c,j}$ [Mpa]	UC opp. [Mpa]	UC bout			
628	Upper chord top ca.	100x100x10	6	M24	15.9	1920	1660	9.6	50	43	0.22	24.2	452	8.9	100	87	0.10			
629	Upper chord top ca.	100x100x10	3	M24	15.9	1920	1660	9.6	50	43	0.22	24.2	452	17.9	100	87	0.21			
630	Earth peak upper chord	130x130x12	0		56.4	3000	3000	18.8	50	43	0.43	76.8	0	0.0	100	87	0.00			
631	Earth peak upper chord	130x130x12	4	M24	48.9	3000	2688	18.2	50	43	0.42	68.8	452	38.0	100	87	0.44			
632	Earth peak upper chord	120x120x10	4	M24	46.3	2320	2060	22.5	50	43	0.52	65.0	452	35.9	100	87	0.41			
633	Earth peak upper chord	120x120x10	0		40.2	2320	2320	17.3	50	43	0.40	56.4	0	0.0	100	87	0.00			
634	Earth peak upper chord	120x120x10	0		31.2	2320	2320	13.4	50	43	0.31	43.7	0	0.0	100	87	0.00			
635	Earth peak upper chord	120x120x10	2	M20	16.6	2320	2100	7.9	50	43	0.18	23.2	314	36.9	100	87	0.42			
637	Stability bracing top ca.	70x70x7	1	M16	9.0	940	814	11.0	50	43	0.25	13.6	201	67.6	100	87	0.78			
638	Earth peak horizontal	UNP160	2	M20	4.7	2400	2235	2.1	50	43	0.05	6.6	314	10.5	100	87	0.12			
640	Vertical side face top ca.	60x60x6	2	M16	3.7	690	582	6.3	50	43	0.15	5.4	201	13.3	100	87	0.15			
641	Vertical side face top ca.	60x60x6	2	M16	13.5	690	582	23.3	50	43	0.54	20.4	201	50.8	100	87	0.58			
642	Vertical side face top ca.	80x80x6	2	M16	3.0	940	832	3.6	50	43	0.08	4.5	201	11.2	100	87	0.13			
643	Vertical side face top ca.	80x80x6	1	M16	0.2	940	832	0.3	50	43	0.01	0.3	201	1.7	100	87	0.02			
644	Vertical side face top ca.	80x80x6	1	M16	6.6	940	832	7.9	50	43	0.18	10.0	201	49.9	100	87	0.57			
645	Vertical side face top ca.	80x80x8	1	M16	0.1	1230	1086	0.1	50	43	0.00	0.2	201	0.8	100	87	0.01			
646	Earth peak vertical side face	60x60x6	1	M16	0.2	690	582	0.4	50	43	0.01	0.3	201	1.5	100	87	0.02			
660	Diag side face top ca.	80x80x6	2	M16	5.4	940	832	6.5	50	43	0.15	7.5	201	18.7	100	87	0.22			
661	Diag side face top ca.	80x80x8	2	M20	5.2	1230	1054	4.9	50	43	0.11	7.7	314	12.3	100	87	0.14			
662	Diag side face top ca.	80x80x6	2	M20	7.0	940	808	8.6	50	43	0.20	10.4	314	16.6	100	87	0.19			
663	Earth peak diag side face	80x80x6	1	M16	0.2	940	832	0.2	50	43	0.01	0.3	201	1.3	100	87	0.01			
664	Stability bracing top ca.	80x80x8	2	M16	17.0	1230	1086	15.7	50	43	0.36	25.8	201	64.1	100	87	0.74			
673	Earth peak diag upper side	60x60x6	2	M16	7.7	690	582	13.3	50	43	0.31	10.8	201	27.0	100	87	0.31			
674	Earth peak diag upper side	60x60x6	2	M16	6.0	690	582	10.2	50	43	0.24	8.4	201	20.9	100	87	0.24			
675	Diag lower plane top ca.	70x70x6	2	M20	13.5	810	678	20.0	50	43	0.46	18.9	314	30.1	100	87	0.35			
676	Diag lower plane top ca.	70x70x6	2	M20	17.1	810	678	25.2	50	43	0.58	23.9	314	38.1	100	87	0.44			
677	Diag lower plane top ca.	70x70x6	2	M20	15.7	810	678	23.2	50	43	0.53	22.0	314	35.1	100	87	0.40			
678	Diag lower plane top ca.	70x70x6	2	M20	13.7	810	678	20.2	50	43	0.47	20.8	314	33.1	100	87	0.38			
679	Diag lower plane top ca.	70x70x6	2	M20	14.9	810	678	22.0	50	43	0.51	22.7	314	36.2	100	87	0.42			
680	Diag lower plane top ca.	70x70x6	2	M20	16.0	810	678	23.6	50	43	0.54	24.4	314	38.8	100	87	0.45			
681	Diag lower plane top ca.	70x70x6	2	M20	25.1	810	678	37.0	50	43	0.85	38.3	314	61.0	100	87	0.70			
682	Diag lower plane top ca.	70x70x6	2	M20	28.1	810	678	41.5	50	43	0.95	42.9	314	68.4	100	87	0.79			
683	Diag lower plane top ca.	80x80x6	2	M20	30.0	940	808	37.2	50	43	0.85	45.8	314	73.0	100	87	0.84			
684	Diag lower plane top ca.	80x80x6	2	M20	30.7	940	808	38.0	50	43	0.87	46.9	314	74.6	100	87	0.86			



**Check galloping - 160gr**

Datum: 16-7-2021  
 Auteur: TBR  
 Versie: 1.0

RLI-TBG  
 HB+6/c

Group	Omschrijving	Profiel	Aantal bouten	Bout	Controle netto oppervlak profiel										Controle boutdoorsnede					
					$\Delta F_{i0}$ [kN]	Brutto [mm <sup>2</sup> ]	Netto [mm <sup>2</sup> ]	$\Delta \sigma_{i0}$ [Mpa]	DC <sub>i0</sub> [Mpa]	$\Delta \sigma_{c,i0}$ [Mpa]	$\Delta F_{i,b}$ [kN]	Bout [mm <sup>2</sup> ]	$\Delta \sigma_{i,b}$ [Mpa]	DC <sub>i,b</sub> [Mpa]	$\Delta \sigma_{c,i,b}$ [Mpa]	UC opp. [Mpa]	UC opp. [kN]	Opp. Bout [mm <sup>2</sup> ]	UC bout	
685	Diag lower plane top ca.	60x60x6	2	M16	11.9	690	582	20.5	50	43	0.47	18.2	201	45.3	100	87	0.52			
686	Earth peak diag lower plane	70x70x7	1	M16	0.4	940	814	0.5	50	43	0.01	0.6	201	3.0	100	87	0.03			
687	Earth peak diag lower plane	70x70x7	1	M16	2.4	940	814	3.0	50	43	0.07	3.6	201	17.9	100	87	0.21			
688	Earth peak diag upper plane	70x70x6	2	M16	8.4	810	702	12.0	50	43	0.28	12.6	201	31.3	100	87	0.36			
689	Earth peak diag upper plane	70x70x6	2	M16	9.3	810	702	13.3	50	43	0.30	13.9	201	34.5	100	87	0.40			
690	Earth peak diag upper plane	60x60x6	2	M16	10.1	690	582	17.3	50	43	0.40	15.0	201	37.3	100	87	0.43			
691	Earth peak diag upper plane	60x60x6	2	M16	11.1	690	582	19.1	50	43	0.44	16.6	201	41.3	100	87	0.47			
692	Earth peak diag upper plane	60x60x6	1	M16	2.3	690	582	4.0	50	43	0.09	3.2	201	16.1	100	87	0.19			
693	Earth peak diag upper plane	60x60x6	1	M16	2.5	690	582	4.4	50	43	0.10	3.6	201	17.8	100	87	0.20			
694	Earth peak diag upper plane	60x60x6	1	M16	2.9	690	582	4.9	50	43	0.11	4.0	201	19.9	100	87	0.23			
695	Earth peak diag upper plane	60x60x6	1	M16	3.3	690	582	5.6	50	43	0.13	4.6	201	22.8	100	87	0.26			
696	Earth peak diag upper plane	60x60x6	1	M16	3.9	690	582	6.7	50	43	0.15	5.5	201	27.2	100	87	0.31			
697	Earth peak diag upper plane	60x60x6	1	M16	4.7	690	582	8.1	50	43	0.19	6.6	201	32.9	100	87	0.38			
698	Plan bracing top ca.	150x150x12	4	M24	59.8	3480	3168	18.9	50	43	0.43	89.8	452	49.7	100	87	0.57			
699	Plan bracing top ca.	140x140x13	5	M24	98.2	3521	3183	30.9	50	43	0.71	147.3	452	65.2	100	87	0.75			
700.3	Hor. Plan bracing hip structu	100x100x8	0		1.2	1550	1550	0.8	50	43	0.02	1.6	0	0.0	100	87	0.00			
701.3	Hor. Plan bracing hip structu	100x100x8	0		0.3	1550	1550	0.2	50	43	0.00	0.4	0	0.0	100	87	0.00			
702.3	Hor. Plan bracing hip structu	100x100x8 (not coupl	0		0.0	3100	3100	0.0	50	43	0.00	0.0	0	0.0	100	87	0.00			
703.3	2nd plan bacing	150x150x12	0		63.6	3480	3480	18.3	50	43	0.42	83.3	0	0.0	100	87	0.00			
704	2nd plan bacing	90x90x8	2	M20	3.0	1390	1214	2.4	50	43	0.06	4.4	314	6.9	100	87	0.08			
705	2nd plan bacing	90x90x8 (not coupled)	2	M20	0.0	2780	2604	0.0	50	43	0.00	0.0	314	0.0	100	87	0.00			
710	Horizontal top of lower ca.	120x120x12	4	M24	12.4	2750	2438	5.1	50	43	0.12	17.6	452	9.7	100	87	0.11			
711	Horizontal top of lower ca.	120x120x10	2	M24	1.0	2320	2060	0.5	50	43	0.01	1.4	452	1.6	100	87	0.02			
712	Horizontal top of mid ca.	120x120x12	4	M24	12.8	2750	2438	5.3	50	43	0.12	17.8	452	9.9	100	87	0.11			
713	Horizontal top of mid ca.	120x120x10	2	M24	1.4	2320	2060	0.7	50	43	0.02	1.7	452	1.9	100	87	0.02			
714	Horizontal top of top ca.	120x120x12	4	M24	19.0	2750	2438	7.8	50	43	0.18	29.0	452	16.0	100	87	0.18			
715	Horizontal top of top ca.	100x100x10	2	M24	0.9	1920	1660	0.6	50	43	0.01	1.4	452	1.5	100	87	0.02			





## **About DNV**

DNV is the independent expert in risk management and assurance, operating in more than 100 countries. Through its broad experience and deep expertise DNV advances safety and sustainable performance, sets industry benchmarks, and inspires and invents solutions.

Whether assessing a new ship design, optimizing the performance of a wind farm, analyzing sensor data from a gas pipeline or certifying a food company's supply chain, DNV enables its customers and their stakeholders to make critical decisions with confidence.

Driven by its purpose, to safeguard life, property, and the environment, DNV helps tackle the challenges and global transformations facing its customers and the world today and is a trusted voice for many of the world's most successful and forward-thinking companies.

## B.6 Mastrapport combi- hoekmasten

ZUID-WEST 380 KV OOST VERBINDINGEN

# Mastrapport combi-hoekmasten HA/c

TenneT TSO B.V.

Meridian doc.nr.: 002.678.00 0928551

Rapport nr.: 21-0773, Rev. 1

Datum: 2021-07-19

DATUM:	30-09-2021
STATUS TENNET:	DEFINITIEF
REVISIE TENNET:	1.0





Projectnaam: Zuid-West 380 kV Oost Verbindingen  
Rapport titel: Mastrapport combi-hoekmasten HA/c  
Klant: TenneT TSO B.V.,  
Contactpersoon klant: XXXXXXXXXX  
Datum uitgave: 2021-07-19  
Project nr.: 10124719  
Organisatie unit: TDT  
Meridian doc.nr.: 002.678.00 0928551  
Rapport nr.: 21-0773, Rev. 1

Energy Systems  
DNV Netherlands B.V.  
Utrechtseweg 310-B50  
6812 AR Arnhem  
  
Tel: 026 356 9111  
Handelsregister Arnhem 09006404

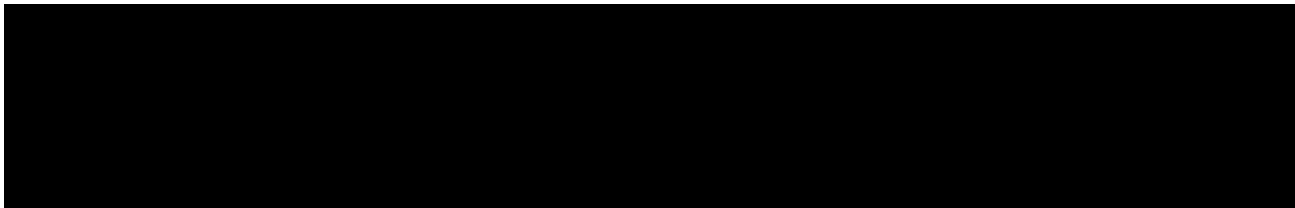

Copyright © DNV 2021. All rights reserved. Unless otherwise agreed in writing: (i) This publication or parts thereof may not be copied, reproduced or transmitted in any form, or by any means, whether digitally or otherwise; (ii) The content of this publication shall be kept confidential by the customer; (iii) No third party may rely on its contents; and (iv) DNV undertakes no duty of care toward any third party. Reference to part of this publication which may lead to misinterpretation is prohibited.

DNV Distributie:

- Open
- Intern
- Commercieel vertrouwelijk
- Vertrouwelijk
- Geheim

\*Specificatie distributie: --

Trefwoorden:

Rev.	Datum	Reden van uitgave	Auteur	Beoordelaar	Goedkeuder
0	2021-05-18	Eerste uitgave	<span style="background-color: black; color: black;">XXXXXXXXXX</span>	<span style="background-color: black; color: black;">XXXXXXXXXX</span>	<span style="background-color: black; color: black;">XXXXXXXXXX</span>
0	2021-07-21	RFA-commentaar verwerkt	<span style="background-color: black; color: black;">XXXXXXXXXX</span>	<span style="background-color: black; color: black;">XXXXXXXXXX</span>	<span style="background-color: black; color: black;">XXXXXXXXXX</span>

## Inhoudsopgave

1	INLEIDING .....	1
2	UITGANGSPUNTEN EN RANDVOORWAARDEN .....	2
2.1	Normen	2
2.2	TenneT-specificaties	2
2.3	Eisenverificatie	2
2.4	Ontwerprapporten	2
2.5	Materialen	2
2.6	Software	3
3	MASTONTWERP .....	4
3.1	Mastbeelden	4
3.2	Uitgangspunten berekening	8
3.3	Mastenlijst	8
3.4	Geleiderbelastingen	9
3.5	Reacties op de fundering	9
3.6	Modellering	9
3.7	Overige controles	9
3.8	Mastgewicht	9
4	TOETSING .....	10
4.1	Resultaat PLS-TOWER	10
4.2	Toetsing overige onderdelen	13
Appendix A	Geleiderbelastingen	
Appendix B	Resultaten PLS tower	
Appendix C	Knikverkorters	
Appendix D	Blokdeuvels	
Appendix E	Liggers	
Appendix F	Sterkte-coördinatie	
Appendix G	Galloping	

## 1 INLEIDING

In het basisontwerp van de vakwerkmasten voor de verbinding RLL-TLB380 in het project Zuid-West 380 kV-Oost zijn voor het vaststellen van de haalbaarheid constructieve berekeningen uitgevoerd aan de masten en fundaties. In de Definitief Ontwerpfase, moeten berekeningen verder worden uitgewerkt om te kunnen dienen voor de benodigde vergunningsdocumentatie, voor de aanbesteding en als voorbereiding voor de uitvoeringsfase. Het DO omvat het ontwerp van de mastconstructies, de fundaties en de opstijpunten in de verbinding.

Deze rapportage bevat de resultaten van de toetsing van alle masttypen binnen de groep van combi-hoekmasten type HA, een masttype geschikt voor 2 circuits 150 kV en 380 kV en geschikt voor lijnhoeken van 180° tot 160°. Het ontwerp van de combi-hoekmasten HA+0/c t/m HA+6/c is zodanig dat de "mastkop" gedeeld wordt binnen de groep van de combi-HA-hoekmasten, alleen de hoogte van het onderstuk verschilt

In deze rapportage is de toetsing van de mastkop van de combi-HA-hoekmasten en de toetsing van alle onderstukken van de verschillende typen opgenomen. De toetsing bestaat uit controle van:

- de profielen en boutverbindingen onderdeel van de hoofd draagconstructie
- de knikverkorters
- de liggers voor de isolatorkettingen
- de verbinding met de fundatie via blokdeuvels
- aanvullende controle op sterkte-coördinatie

Buiten de scope van dit DO-rapport valt de controle van de schetsplaten en overige verbindingdetails in de constructie. Dit moet in de UO-fase worden uitgewerkt. Ook de voorzieningen voor de high-step rail en bordessen vallen onder uitwerking in UO-fase.

In hoofdstuk 2 zijn de uitgangspunten en randvoorwaarden vanuit de van toepassing zijnde normen en TenneT-specificaties opgenomen. Hoofdstuk 3 beschrijft de gevolgde aanpak van de berekening. In hoofdstuk 4 is de toetsing opgenomen.

## 2 UITGANGSPUNTEN EN RANDVOORWAARDEN

### 2.1 Normen

Er is gebruik gemaakt van de normen volgens Tabel 1.

**Tabel 1 Gebruikgemaakte normen, voorschriften en richtlijnen**

Norm	Titel
NEN-EN 50341-1:2013	“Overhead electrical lines exceeding AC 1 kV - Part 1: General requirements – Common”
NEN-EN 50341-2-15:2019	“Overhead electrical lines exceeding AC 1 kV Part 2 National Normative Aspects (NNA) for THE NETHERLANDS”
NEN-EN 1990+A1+A1/C2:2019/NB:2019nl	“Grondslagen van het ontwerp”
NEN-EN 1991-1-4+A1+C2:2011/NB:2019+C1:2020	“Deel 1-4: Windbelasting op constructies”
NEN-EN 1992-1-1+C2:2011/NB:2016+A1:2020	“Eurocode 2: Ontwerp en berekening van betonconstructies, deel 1-1: algemene regels en regels voor gebouwen”
NEN-EN 1993-1-1+C2+A1:2016 nl	“Eurocode 3: Ontwerp en berekening van staalconstructies, deel 1-1: algemene regels en regels voor gebouwen”
NEN-EN 1993-3-1:2007/NB:2011 nl	“Deel 3-1: Torens, masten en schoorstenen - Torens en masten”
NEN-EN 1993-1-8+C2:2011/NB:2011 nl	“Ontwerp en berekening van staalconstructies, deel 1-8: ontwerp en berekening van verbindingen”

### 2.2 TenneT-specificaties

In Tabel 2 zijn de documenten opgenomen die relevant zijn voor de berekeningen en toetsingen die binnen dit project in de mastrapportage uitgevoerd zullen worden.

**Tabel 2 Relevante documenten t.b.v. mechanische rapportages**

Nummer	Onderwerp
PVE.05.000 v3.2	PvE Lijnen
sPVE.05.001	sPvE Lijnen
SPE.05.346 v1.3	Algemene specificatie stalen masten

### 2.3 Eisenverificatie

Voor de eisenverificatie wordt verwezen naar het rapport “Verificatierapport eisen DO Moldau”, DNV GL rapport 21-0451, Meridiannummer 002.678.00 0910757.

### 2.4 Ontwerppapporten

Voor de achtergrond van het ontwerp wordt verwezen naar het uitgangspuntenrapport “Uitgangspunten definitief ontwerp Moldaumast”, DNV GL rapport 21-0036, Meridiannummer 002.678.00 0876917.

### 2.5 Materialen

Voor het ontwerp van de mastconstructies en fundaties wordt uitgegaan van de eigenschappen volgens Tabel 3.

**Tabel 3 Materialen aangepaste constructie**

Staalsoort	S355J0 (t≤16 mm) S355J2 (16<t≤40 mm)
Boutkwaliteit	8.8 gerolde draad
Betonkwaliteit	C30/37
Wapeningsstaal	B500



Voor de constructie geldt conform TenneT-specificatie:

- Toe te passen bouten: M16/M20/M24;
- Voor hoekstaal is de minimale afmeting L50x5 mm;
- Minimale plaatdikte 6 mm.

Mocht het noodzakelijk zijn M30 toe te passen, bij grote plaatdiktes is dit als afwijking door TenneT toegestaan.

## 2.6 Software

De gebruikte software wordt benoemd in Tabel 4.

**Tabel 4 Toegepaste software**

Software		Versie
Mastontwerp	PLS-CADD	16.65
Mastberekeningen	PLS-TOWER	16.65
Constructieve analyse	AxisVM	X5 R4h





### 3 MASTONTWERP

#### 3.1 Mastbeelden

In dit hoofdstuk worden de mastbeelden weergegeven met de belangrijkste maatvoering, voor volledige tekeningen van de masttypen wordt verwezen naar onderstaande tekeningen:

- Mastbeeldtekening HA+0/c, Meridiannummer 002.678.00 0901943
- Mastbeeldtekening HA+3/c, Meridiannummer 002.678.00 0927472
- Mastbeeldtekening HA+6/c, Meridiannummer 002.678.00 0927480

Masttype HA/c is een combimast voor twee circuits 380 kV en twee circuits 150kV. De belastingen grijpen als trekkrachten aan via de afspankettingen. Onder de traverse bevinden zich verticale post-isolatoren die de bretellebogen fixeren

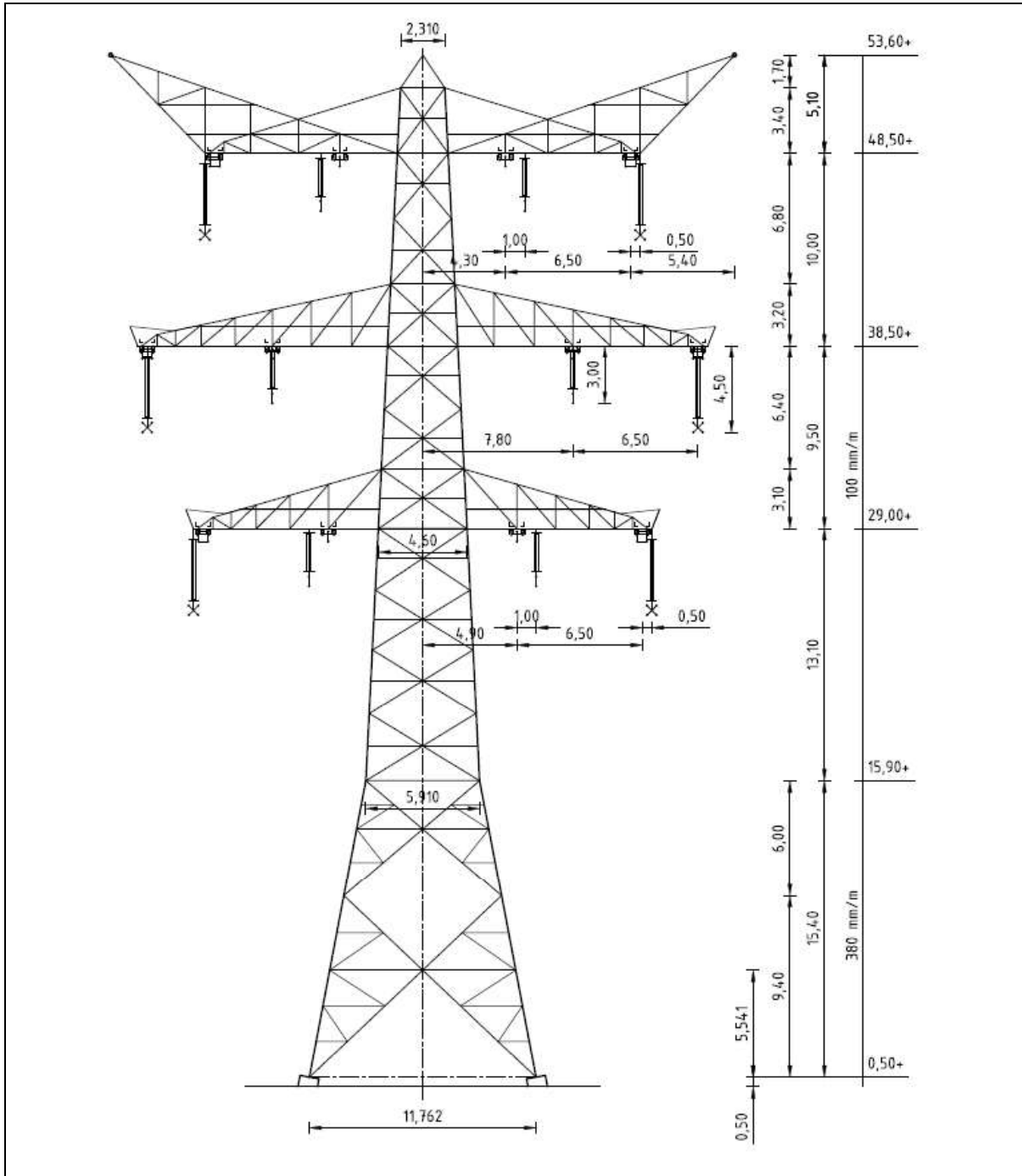

Figuur 1 Mastbeeld masttype HA+0/c

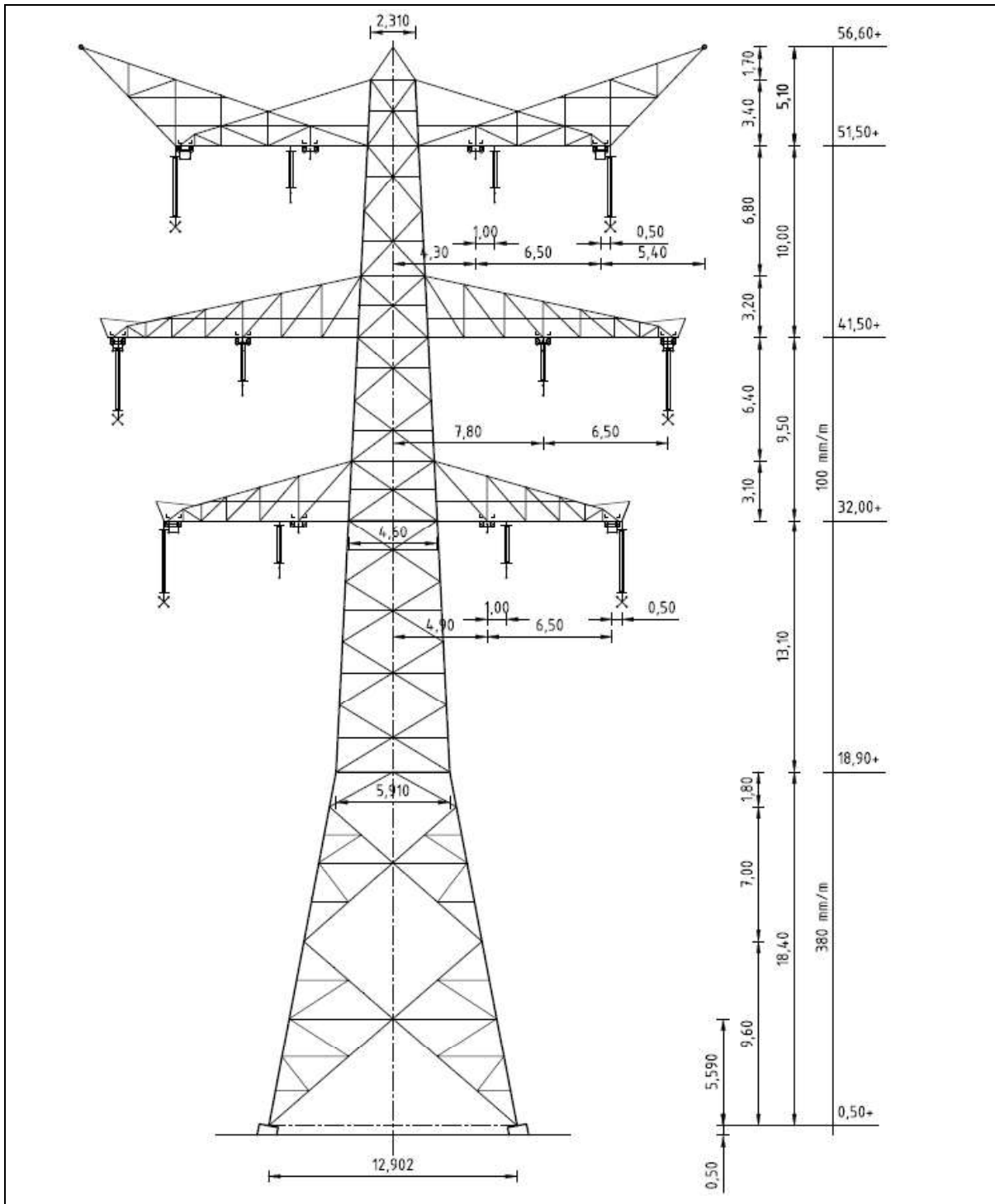

Figuur 2 Mastbeeld masttype HA+3/c

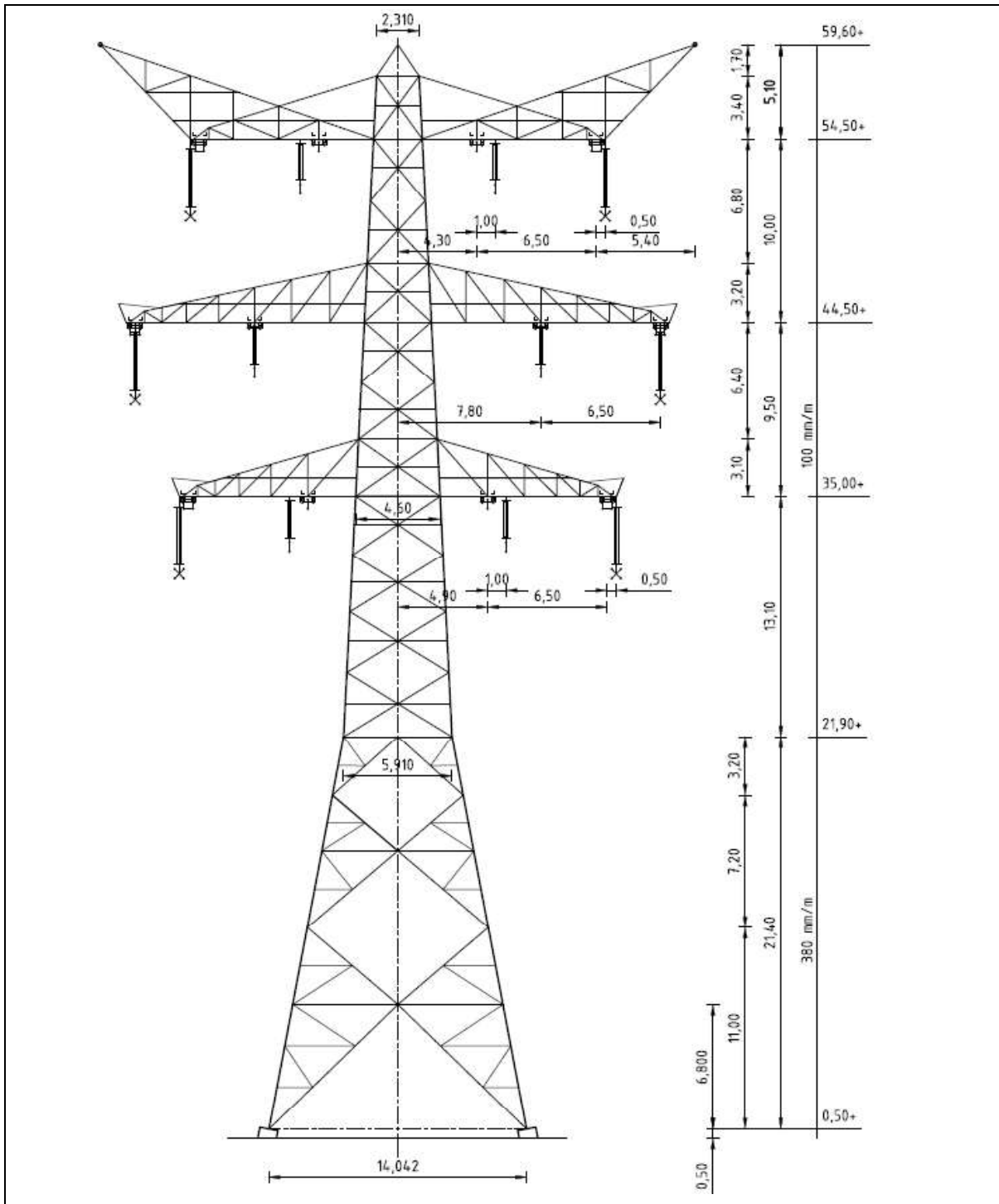

Figuur 3 Mastbeeld masttype HA+6/c

### 3.2 Uitgangspunten berekening

De uitgangspunten volgens Tabel 5 zijn van toepassing.

**Tabel 5 Uitgangspunten**

Norm	NEN-EN50341-2-15:2019
Gevolgklasse initieel	CC2
Betrouwbaarheidsniveau	Nieuwbouw
Referentieperiode	50 jaar
Windgebied	III
Windsnelheid (m/s)	24,5
Terreincategorie	II
Reductiefactor $c_{dir}$	1,00
IJsg gebied fasegeleider	B
IJsg gebied bliksemgeleider	A

### 3.3 Mastenlijst

De mastenlijst is gebaseerd op de “staging table” van het DO-uitgangspuntenrapport en vernoemd als “VKA 1.1 Concept 20201112 1037-1044\_1086-1094\_1099-1105\_1192-1204.xlsx”. De mastenlijst is vanwege lopende traceringsvraagstukken aan verandering onderhevig en is derhalve indicatief.

In Tabel 6 *tot en met* Tabel 8 zijn alle masten in het tracé van het type HA+0/c, HA+3/c en HA+6/c opgenomen. De mast met grootste wind span is vetgedrukt aangegeven. Het masttype zal niet met deze wind en weight span worden berekend maar met generieke wind en weight span, zie uitgangspuntenrapport.

**Tabel 6 Mastenlijst Masttype HA+0**

Mast-nummer	Masttype	Lijnhoek (°)	Wind span (m)	Weight span (m)	Hoogteverschil ba+ah (m)	Hoogteverschil back (m)	Hoogteverschil ahead (m)
1044	HA+0_c	171,9	332,7	316,0	-2,8	-3,4	0,7
1086	HA+0_c	174,6	359,0	329,3	-6,3	-0,2	-6,1
1105	HA+0_c	176,9	368,6	354,9	-3,0	-2,9	-0,1
1123	HA+0_c	167,7	358,6	356,0	-0,5	-0,6	0,1
1130	HA+0_c	163,6	331,6	335,7	0,7	0,0	0,7
<b>1188</b>	HA+0_c	161,4	386,4	387,8	0,3	0,6	-0,3
1195	HA+0_c	168,9	269,6	262,0	-1,1	-0,1	-1,1

**Tabel 7 Mastenlijst Masttype HA+3**

Mast-nummer	Masttype	Lijnhoek (°)	Wind span (m)	Weight span (m)	Hoogteverschil ba+ah (m)	Hoogteverschil back (m)	Hoogteverschil ahead (m)
<b>1094</b>	HA+3_c	167,0	382,9	384,8	0,4	0,3	0,1
1095	HA+3_c	180,0	375,2	388,6	2,9	-0,1	3,0

**Tabel 8 Mastenlijst Masttype HA+6**

Mast-nummer	Masttype	Lijnhoek (°)	Wind span (m)	Weight span (m)	Hoogteverschil ba+ah (m)	Hoogteverschil back (m)	Hoogteverschil ahead (m)
<b>1067</b>	HA+6_c	167,6	352,7	381,9	5,0	4,9	0,1
1068	HA+6_c	173,3	397,1	399,1	0,4	-0,1	0,6
1069	HA+6_c	175,9	363,0	374,4	2,0	-0,6	2,5
1078	HA+6_c	173,8	398,8	374,3	-5,4	-5,8	0,4

### 3.4 Geleiderbelastingen

De berekening is uitgevoerd met het geleiderbelastingprogramma van DNV GL. De belastingen op de mastconstructie zijn bepaald op basis van de modellering in PLS-TOWER (staafoppervlaktes). Voor de toeslagen op eigen gewicht en windoppervlakte wordt verwezen naar het uitgangspuntenrapport. In Appendix A zijn de resultaten van de geleiderbelastingen samengevat.

### 3.5 Reacties op de fundering

De oplegreacties op de fundering worden ontleend aan de uitvoer van het geleiderbelastingprogramma. Zie Appendix A.

### 3.6 Modelling

Op basis van de ontwerptekeningen is de mast in PLS-TOWER ingevoerd. De toetsing wordt per staafgroep uitgevoerd. De hoofdelementen zijn gemodelleerd, niet-dragende profielen als knikverkorters zijn weggelaten, deze worden separaat getoetst. De profielen zijn in PLS-TOWER inclusief de boutverbindingen ingevoerd en getoetst, de controle van de schetsplaten en andere detailverbindingen valt buiten de scope.

De geleiderbelastingen vanuit het geleiderbelastingprogramma zijn als invoer voor de belastingen gebruikt.

De gewichts- en windbelasting op de mastconstructie wordt door PLS-TOWER automatisch bepaald. Via toeslagfactoren wordt de invloed van niet gemodelleerde elementen als knikverkorters, bordesconstructies en klimvoorzieningen meegenomen. Voor schetsplaten, zinklaag en bouten is een aanvullende toeslag op het gewicht van 20% toeslag gerekend.

Diagonalen in voor- en achtervlak respectievelijk de twee zijvlakken zijn samengenomen in een groep.

### 3.7 Overige controles

In PLS-TOWER zijn niet alle elementen getoetst. Knikverkorterprofielen en overige profielen voor beloopbaarheid worden separaat getoetst. In Appendix C is dit opgenomen. De verbinding met de fundatie bestaat uit ingestorte profielen voorzien van blokdeuvels. Dit is in Appendix D opgenomen. De liggers van isolatorkettingen vereisen een aanvullende controle op buiging. De toetsing is uitgevoerd met de software AxisVM en is beschreven in Appendix E. Appendix F omvat de toetsing op sterkte-coördinatie. Voor hoekmasten moet een toetsing op vermoeiing worden uitgevoerd voor galloping. Dit is in Appendix G opgenomen.

De mastranden uitgevoerd als XEA-profielen worden separaat op torsieknik gecontroleerd. Dit is in Appendix B opgenomen. De berekende capaciteit die lager is dan de capaciteit voor buigingsknik is in PLS-TOWER via aangepaste buckling-ratio ingevoerd.

### 3.8 Mastgewicht

Het totale mastgewicht per masttype is met de uitgangspunten van paragraaf 3.6 bepaald op:

- Masttype HA+0/c -> 99,5 ton;
- Masttype HA+3/c -> 107,0 ton;
- Masttype HA+6/c -> 114,6 ton.

## 4 TOETSING

### 4.1 Resultaat PLS-TOWER

Het resultaat van de toetsing met PLS-TOWER is per masttype weergegeven in Figuur 2 tot en met Tabel 8. Voor elk masttype zijn de belastingen apart bepaald. Alléén voor masttype HA+6/c bepalend voor het ontwerp van de mastkop, zijn deze ook inclusief bouwphase en afspannen

De uitnutting van de constructie loopt op van blauw (0-25%) tot geel (75-100%). Uit de figuur wordt geconcludeerd dat alle profielen en boutverbindingen voldoen.

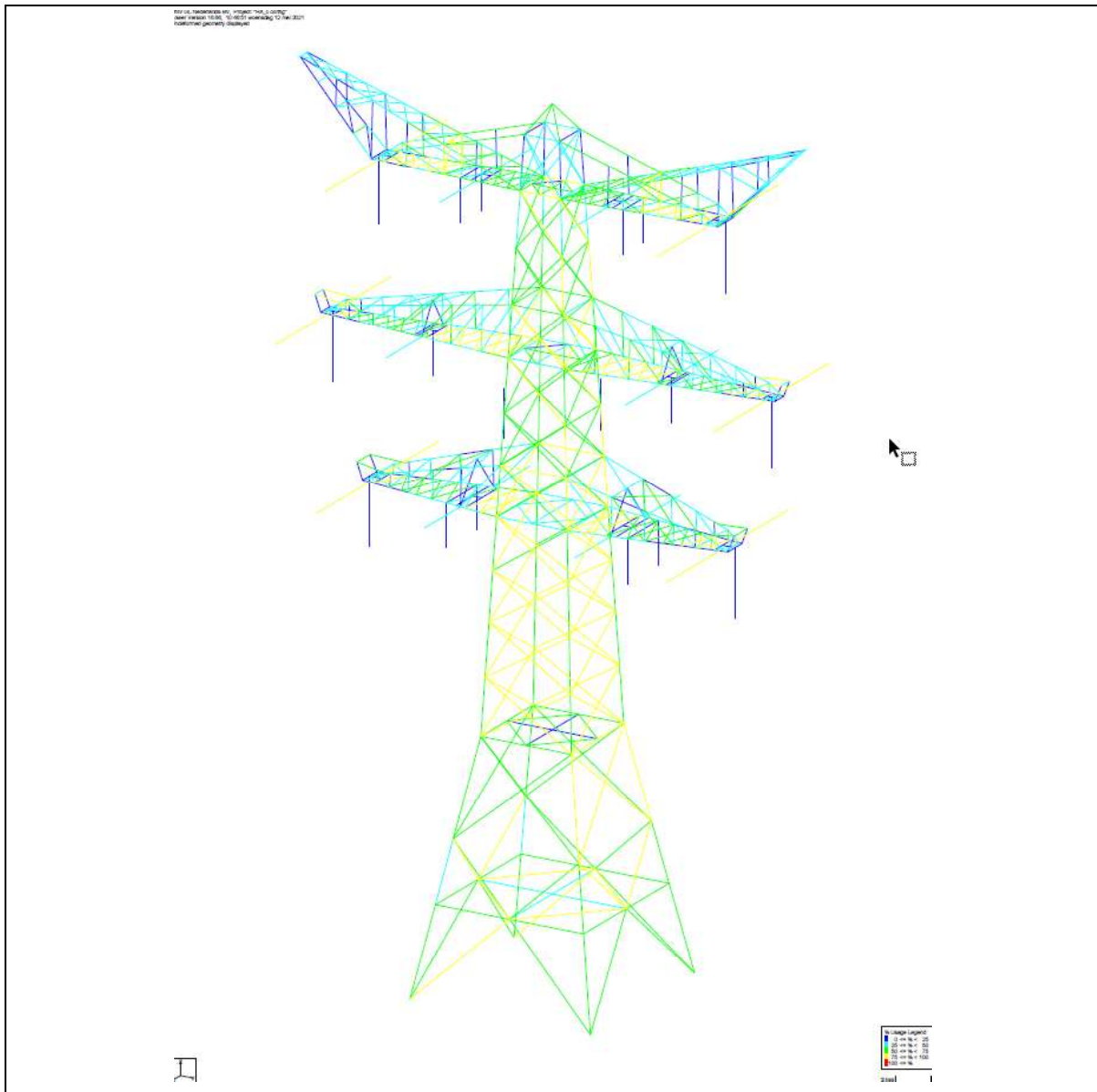

**Figuur 4 Resultaat PLS-TOWER voor masttype HA+0/c**

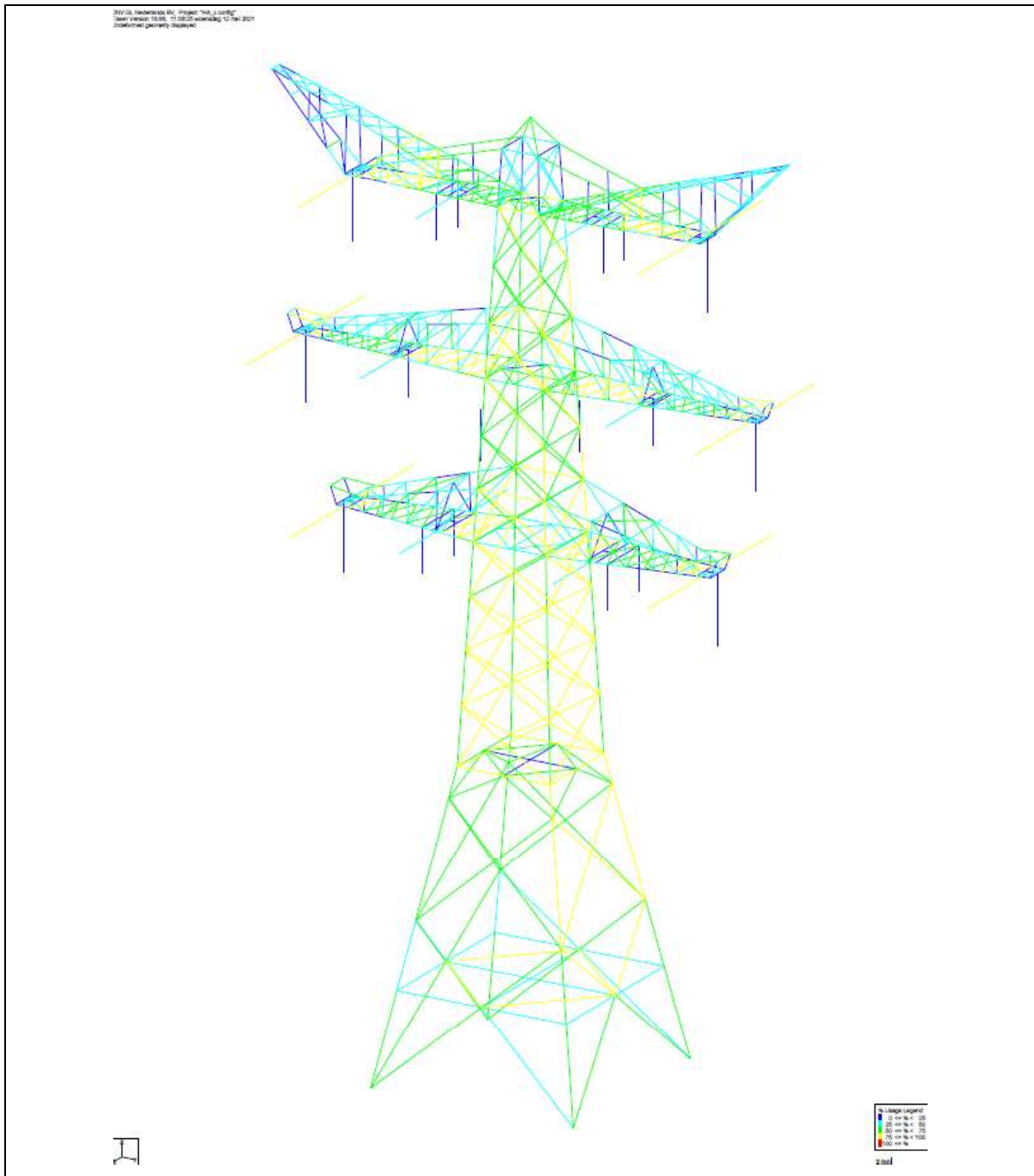

**Figuur 5** Resultaat PLS-TOWER voor masttype HA+3/c



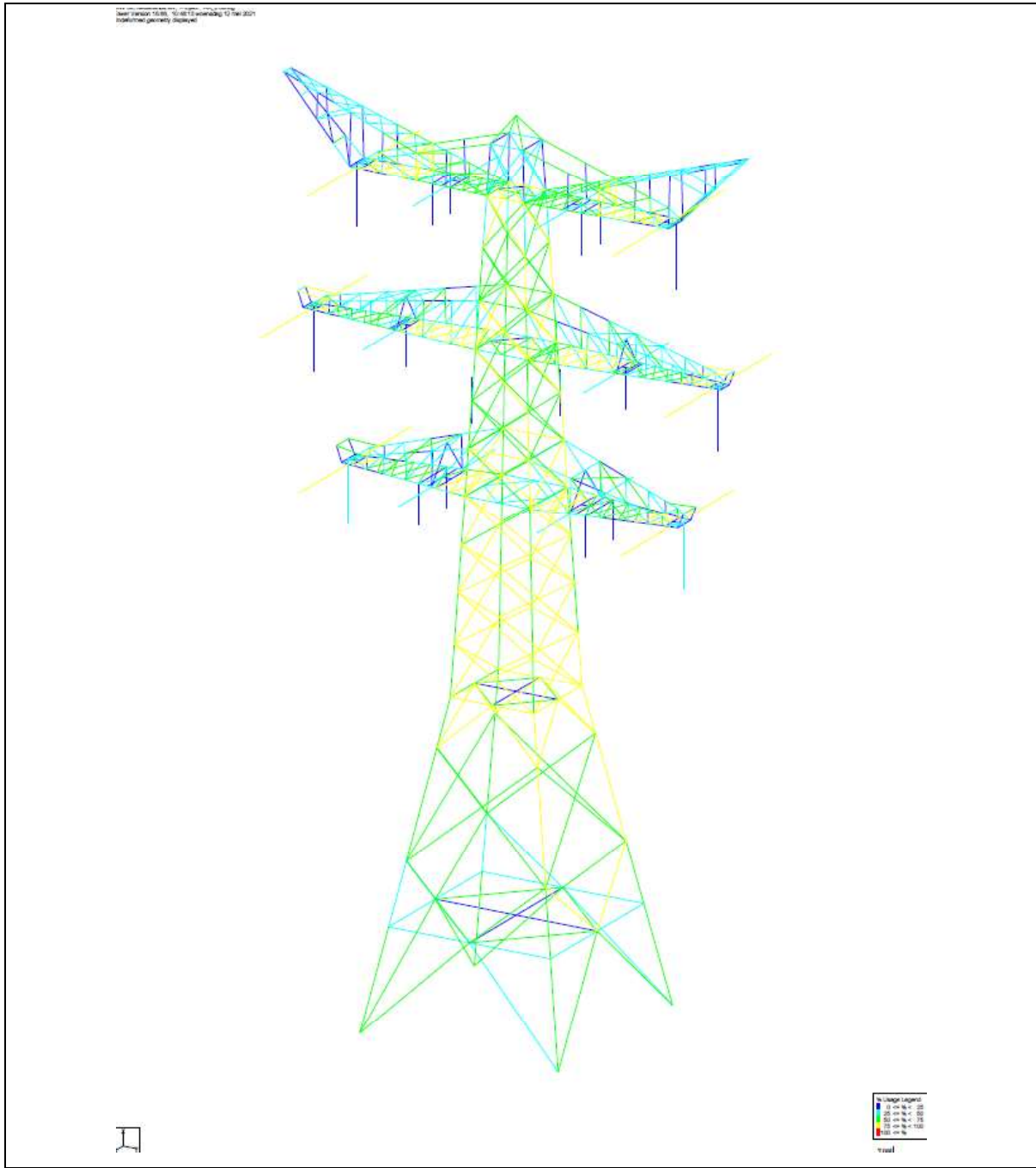

**Figuur 6 Resultaat PLS-TOWER voor masttype HA+6/c**

## 4.2 Toetsing overige onderdelen

In Tabel 7 zijn de resultaten van de uitgevoerde toetsingen weergegeven.

**Tabel 9 Samenvatting uitgevoerde controles**

Controle van	Beoordeling	Referentie
Profielen	Voldoen	Figuur 4 Figuur 5 Figuur 6 Appendix B
Knikverkorters	Voldoen	Appendix C
Blokdeuvels randstijl	Voldoen	Appendix D
Liggers	Voldoen	Appendix E
Sterkte-coördinatie	Voldoet	Appendix F

## APPENDIX A

### Geleiderbelastingen

---

Geleiderbelastingen opgenomen:

- Masttype HA+0/c
- Masttype HA+3/c
- Masttype HA+6/c
- Masttype HA+6/c bouwfase
- Afspannen



Project: RLL-TLB380  
Tower: HA+0\_c  
Number: 1188

Auteur: TBR  
Versie: v12.0

### Geleiderbelastingen

#### Algemeen

Benaming HA+0\_c  
Masttype Hoekmast  
Aantal circuits 4  
Configuratie 4-circuit-dubbel verticaal  
Aantal bliksemgeleiders 2

#### Uitgangspunten

Norm NEN-EN50341-2-15:2019  
Gevolgklasse initieel CC2  
Betrouwbaarheidsniveau initieel Nieuwbouw  
Referentieperiode initieel 50 jaar  
Betrouwbaarheidsniveau na aanpassing n.v.t.  
50 jaar  
Windgebied III  
Windsnelheid (m/s) 24,5 m/s  
Terreincategorie II  
Reductiefactor  $C_{dir}$  1,00  
IJsgebied fasegeleider B  
IJsgebied bliksemgeleider A

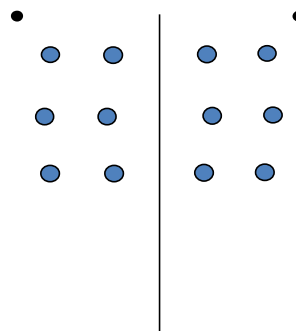

Configuratie geleiders

#### Geleiders Back

Omschrijving	Spanning	Geleider Back	Bundel Ba	IJsgebied	Toeslag gewicht	Toeslag diameter	Intrekwaarden $P_{back}$
Circuit 1	380 kV	AAAC-AL7 620	4	B	3 %	3 %	1800
Circuit 2	380 kV	AAAC-AL7 620	4	B	3 %	3 %	1800
Circuit 3	150 kV	AAAC-AL7 620	2	B	3 %	3 %	1800
Circuit 4	150 kV	AAAC-AL7 620	2	B	3 %	3 %	1800
Bliksemdraad 1		AACSR 241-AL3-39-A20SA	1	A	2 %	2 %	1800
Bliksemdraad 2		OPGW AFL-226/38	1	A	2 %	2 %	1800

#### Geleiders Ahead

Omschrijving	Spanning	Geleider Ahead	Bundel Ah	IJsgebied	Toeslag gewicht	Toeslag diameter	Intrekwaarden $P_{ahead}$
Circuit 1	380 kV	AAAC-AL7 620	4	B	3 %	3 %	1800
Circuit 2	380 kV	AAAC-AL7 620	4	B	3 %	3 %	1800
Circuit 3	150 kV	AAAC-AL7 620	2	B	3 %	3 %	1800
Circuit 4	150 kV	AAAC-AL7 620	2	B	3 %	3 %	1800
Bliksemdraad 1		AACSR 241-AL3-39-A20SA	1	A	2 %	2 %	1800
Bliksemdraad 2		OPGW AFL-226/38	1	A	2 %	2 %	1800

#### Isolatoren (1)

Omschrijving	Ophanging	Gewicht [kN]	Lengte [m]	Windopp. [m <sup>2</sup> ]
Circuit 1	Afspanketting	3,00	6,50	1,10
Circuit 2	Afspanketting	3,00	6,50	1,10
Circuit 3	Afspanketting	2,00	3,50	0,80
Circuit 4	Afspanketting	2,00	3,50	0,80
Bliksemdraad 1	Afspanketting	0,10	0,20	0,10
Bliksemdraad 2	Afspanketting	0,10	0,20	0,10

1. Eigenschappen gelden voor geheel van de isolatorset

#### Ophanghoogte en positie in mast

Circuits	Aanduiding	Nummer	Ophanghoogte	Aangrijppunt	Positie in mast Horizontale afstand
Circuit 1	10	380ct1f1	48,0 m	48,0 m	-10,8 m
Circuit 1	11	380ct1f2	38,0 m	38,0 m	-14,3 m
Circuit 1	12	380ct1f3	28,5 m	28,5 m	-11,4 m
Circuit 2	40	380ct2f1	48,0 m	48,0 m	10,8 m
Circuit 2	41	380ct2f2	38,0 m	38,0 m	14,3 m
Circuit 2	42	380ct2f3	28,5 m	28,5 m	11,4 m
Circuit 3	20	150ct3f1	48,0 m	48,0 m	-4,3 m
Circuit 3	21	150ct3f2	38,0 m	38,0 m	-7,8 m
Circuit 3	22	150ct3f3	28,5 m	28,5 m	-4,9 m
Circuit 4	30	150ct4f1	48,0 m	48,0 m	4,3 m
Circuit 4	31	150ct4f2	38,0 m	38,0 m	7,8 m
Circuit 4	32	150ct4f3	28,5 m	28,5 m	4,9 m
Bliksemdraad 1	1	bl1	53,1 m	53,1 m	-16,2 m
Bliksemdraad 2	3	bl2	53,1 m	53,1 m	16,2 m

Project: RLL-TLB380  
 Tower: HA+0\_c  
 Number: 1188

**Hoogteaanpassing naastgelegen masten** (aanpassing wind- en weight span)

	Back	Ahead	
Verhoging voor windbelasting	18,0 m	6,0 m	(positief: omhoog)
Verlaging voor verticale belasting	-9,0 m	-9,0 m	(negatief: omlaag, grotere weight span)
Verlaging:	Niet in 0,9EG-combinaties		

**Hoogteafwijking mastbeeld naastgelegen masten en richtingsverandering t.o.v. Lijnrichting**

Circuits	Aanduiding	Nummer	Hoogteverschil		Richtingsverandering	
			$\Delta h$ back	$\Delta h$ ahead	$\Delta y$ back	$\Delta y$ ahead
Circuit 1	10	380ct1f1	0,0	0,0 m	0,0	0,0 m
Circuit 1	11	380ct1f2	0,0	0,0 m	0,0	0,0 m
Circuit 1	12	380ct1f3	0,0	0,0 m	0,0	0,0 m
Circuit 2	40	380ct2f1	0,0	0,0 m	0,0	0,0 m
Circuit 2	41	380ct2f2	0,0	0,0 m	0,0	0,0 m
Circuit 2	42	380ct2f3	0,0	0,0 m	0,0	0,0 m
Circuit 3	20	150ct3f1	0,0	0,0 m	0,0	0,0 m
Circuit 3	21	150ct3f2	0,0	0,0 m	0,0	0,0 m
Circuit 3	22	150ct3f3	0,0	0,0 m	0,0	0,0 m
Circuit 4	30	150ct4f1	0,0	0,0 m	0,0	0,0 m
Circuit 4	31	150ct4f2	0,0	0,0 m	0,0	0,0 m
Circuit 4	32	150ct4f3	0,0	0,0 m	0,0	0,0 m
Bliksemdraad 1	1	bl1	0,0	0,0 m	0,0	0,0 m
Bliksemdraad 2	3	bl2	0,0	0,0 m	0,0	0,0 m

**Lijn- en mastgegevens**

	Back	Ahead
Ruling span $\sqrt{(\Sigma L^3)/\Sigma L}$	400,0	400,0 m
Lijnhoek $\beta$	160 °	
Rotatie mast t.o.v. bissectrice $\theta$	0 °	
Vaklengte	400	400 m
Hoogte onderkant mast t.o.v. maaiveld	0,5 m	
Beschouwde windrichtingen	$\alpha_1$	0 °
Windrichtingen volgens:	$\alpha_2$	45 °
Geleiderbelastingen	$\alpha_3$	90 °
	$\alpha_4$	135 °
	$\alpha_5$	80 °
	$\alpha_6$	100 °

Windrichtingen gelden t.o.v. hoofdrichting mastconstructie, niet t.o.v. bissectrice.

Windrichtingen en positieve richtingen belastingen

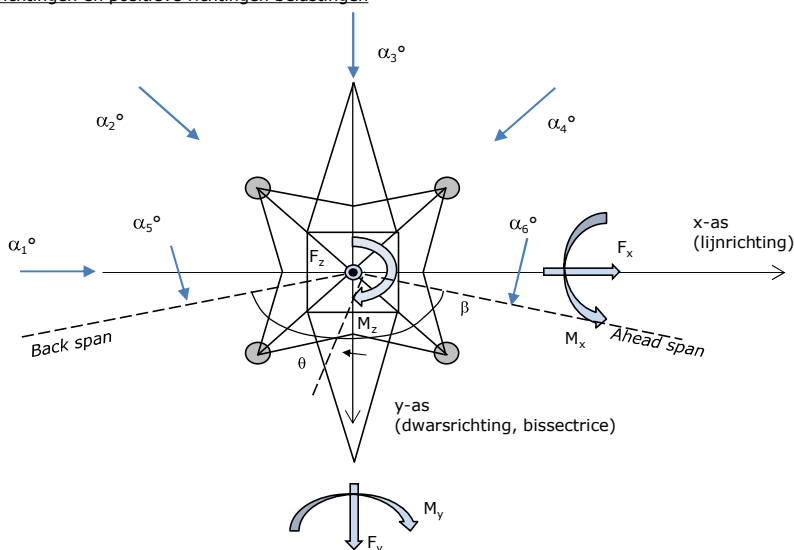

**Beschouwd aantal windrichtingen**

1a	6
3	6
4	1
6	1
Overig	1

Project: RLL-TLB380  
 Tower: HA+0\_c  
 Number: 1188

### Geleiderafval

		SPLS - torsie		SPLS - Enkelzijdige trek		5a - geleiderbreuk	
		Aanw.	Afw.	Aanw.	Afw.	Aanw.	Afw.
Circuit 1	380ct1f1	1	0	1	0	1	0
Circuit 1	380ct1f2	1	0	1	0	1	0
Circuit 1	380ct1f3	1	0	1	0	1	0
Circuit 2	380ct2f1	0	1	1	0	1	0
Circuit 2	380ct2f2	0	1	1	0	1	0
Circuit 2	380ct2f3	0	1	1	0	1	0
Circuit 3	150ct3f1	1	0	1	0	1	0
Circuit 3	150ct3f2	1	0	1	0	1	0
Circuit 3	150ct3f3	1	0	1	0	1	0
Circuit 4	150ct4f1	0	1	1	0	1	0
Circuit 4	150ct4f2	0	1	1	0	1	0
Circuit 4	150ct4f3	0	1	1	0	1	0
Bliksemdraad 1	b11	1	0	1	0	1	0
Bliksemdraad 2	b12	0	1	1	0	1	0

### Belastingssituaties SPLS

Beschouwde situaties SPLS: 1 t/m 6, alle mogelijke situaties.

Principe belastingssituaties:

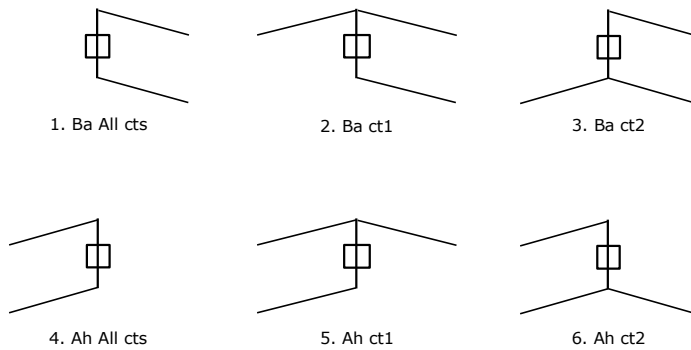

### Belastingssituaties 5a. Geleiderbreuk

Beschouwde situaties geleiderbreuk 5a: 1 en 2, alle mogelijke situaties.

Principe belastingssituaties:

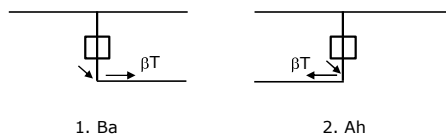

Project: RLL-TLB380  
 Tower: HA+0\_c  
 Number: 1188

### Belastingsituaties 6. Bouw- en onderhoud

Onder 6a wordt de belasting door aanwezigheid lijnwagen of lijnfiets in combinatie met puntlast op traverse in rekening gebracht. Combinatie 6b bevat geen belastingen in geleider of op traverse. Deze combinatie is toegevoegd om te kunnen combineren met separate controle bordessen etc. De situaties worden in ULS en in iedere SPLS-situatie (in geval van hoekmast) toegepast.

	Fase	Bliksem
Lijnwagen	4,0 kN	2,0 kN
Puntlast op traverse	1,0 kN	1,0 kN

Beschouwde situaties bouw- en onderhoud 6a: 1 t/m 4, alle mogelijke situaties.

Aanwezigheid lijnwagen: Circuit, belasting tegelijk aanwezig in alle geleiders per circuit.

Principe belastingssituaties:

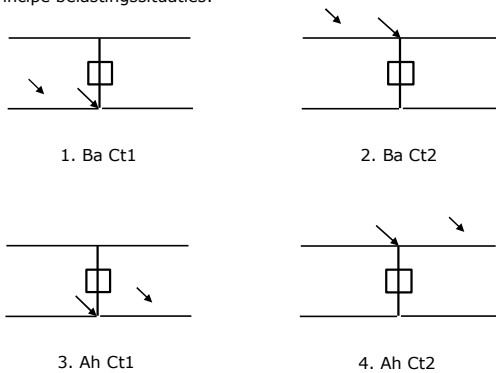

### Belastingsituaties 8. Lijndansen als statische belasting

Geleider		
Steunmast fase	0,866 W	1,5 W
Steunmast bliksem	1,5 EDS	1,5 W
Hoekmast fase en bliksem	1,5 EDS	1,5 W

Beschouwde situaties lijndansen 8: 1 en 2, alle mogelijke situaties.

Belasting tegelijk aanwezig in alle geleiders van het circuit.

Principe belastingssituaties:

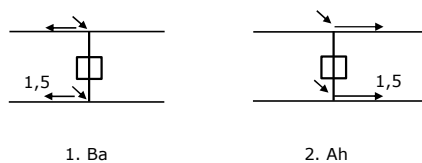

### Belastingcombinatie 8. Lijndansen als dynamische belasting

Alleen van toepassing op hoek- en eindmasten

Belasting bestaat uit EDS-trekbelasting in één van de geleiders aan één zijde van de mast

Door gebruiker via het belastingsspectrum van tabel 4.11/NL.1 om te zetten naar spanningspectrum



Project: RLL-TLB380  
 Tower: HA+0\_c  
 Number: 1188

## Mastconstructie

### Eigenschappen

Masttype	Hoekmast	
Mastbenaming	HA+0_c	
Voetplaat t.o.v. maaiveld	0,5 m	
Masthoogte t.o.v. voetplaat	53,1 m	
Gewicht mast	976,4 kN	
<i>Breedte en helling mast bij fundatie</i>	x-ri.	y-ri.
Pootsprei	11,76	11,76 m
Helling van de randstijl	0,190	0,190 -
Factor spatkracht	1,1	1,1 -

### Berekening windbelasting

Dynamische invloed $G_T$	1,00 ( <i>Masthoogte &lt; 60 m</i> )
Windbelasting overhoeks op mastlichaam evenredig met:	$(A1C1\sin^2(\phi)+A2C2\cos^2(\phi))$
Windbelasting overhoeks op traverse evenredig met:	$(A1C1\sin^2(\phi)+A2C2\cos^2(\phi))$
Vergroting wind overhoeks mastlichaam	$(1+0,2\sin^2(2\phi))$
Vergroting wind overhoeks traverse	$(1+0,2\sin^2(2\phi))$
Factor wind evenwijdig t.o.v. haaks op traverse	0,4

### Eigenschappen mastsecties langsrichting (vooraanzicht, yz-vlak)

Omschrijving	h [m]	b <sub>1</sub> [m]	b <sub>2</sub> [m]	Δh [m]	Δ <sub>x</sub> [m]	A <sub>0</sub> [m <sup>2</sup> ]	A <sub>1</sub> [m <sup>2</sup> ]	χ = A <sub>1</sub> /A <sub>0</sub> [-]	C <sub>t</sub>
Broekstuk	15,40	11,76	5,91	15,40	0,190	136,07	31,47	0,23	2,80
Eerste tussenstuk	22,20	5,91	5,23	6,80	0,050	37,88	13,24	0,35	2,37
Tweede tussenstuk	28,50	5,23	4,60	6,30	0,050	30,96	10,25	0,33	2,43
Bovenstuk 1	38,00	4,60	3,65	9,50	0,050	39,19	11,88	0,30	2,52
Bovenstuk 2	51,40	3,65	2,31	13,40	0,050	39,93	13,01	0,33	2,45
Topstuk	53,10	2,31		1,70		1,96	0,33	0,17	3,08
Ondertraverse	28,50	9,40		3,10		14,57	4,37	0,30	2,54
Middentraverse	38,00	12,78		3,20		20,45	6,34	0,31	2,50
Boventraverse	48,00	14,88		5,10		37,93	7,34	0,19	2,96

### Eigenschappen mastsecties dwarsrichting (zijaanzicht, xz-vlak)

Omschrijving	h [m]	b <sub>1</sub> [m]	b <sub>2</sub> [m]	Δh [m]	Δ <sub>x</sub> [m]	A <sub>0</sub> [m <sup>2</sup> ]	A <sub>1</sub> [m <sup>2</sup> ]	χ = A <sub>1</sub> /A <sub>0</sub> [-]	C <sub>t</sub>
Broekstuk	15,40	11,76	5,91	15,40	0,190	136,07	31,47	0,23	2,80
Eerste tussenstuk	22,20	5,91	5,23	6,80	0,050	37,88	13,24	0,35	2,37
Tweede tussenstuk	28,50	5,23	4,60	6,30	0,050	30,96	10,25	0,33	2,43
Bovenstuk 1	38,00	4,60	3,65	9,50	0,050	39,19	11,88	0,30	2,52
Bovenstuk 2	51,40	3,65	2,31	13,40	0,050	39,93	13,01	0,33	2,45
Topstuk	53,10	2,31		1,70		1,96	0,33	0,17	3,08
Ondertraverse	28,50	9,40		3,10		14,57	4,37	0,30	2,54
Middentraverse	38,00	12,78		3,20		20,45	6,34	0,31	2,50
Boventraverse	48,00	14,88		5,10		37,93	7,34	0,19	2,96

NB: oppervlakte traverse dwarsrichting van de tabel wordt in berekening gereduceerd.  
 NB: oppervlakte traverse per zijde, dus helft van totaal van twee traverses.

Project: RLL-TLB380  
 Tower: HA+0\_c  
 Number: 1188

#### Windoppervlak feeders telecominstallaties

Onderdeel	A (m <sup>2</sup> /m)	Factor	Δh	A <sub>1</sub>
Broekstuk	0,14	0,71	15,4	1,5
Eerste tussenstuk	0,14	0,71	6,8	0,7
Tweede tussenstuk	0,14	0,71	6,3	0,6
Bovenstuk 1	0,14	0,71	9,5	0,9
Bovenstuk 2				

#### Invoer antennes

Omschrijving	A (m <sup>2</sup> )	h (m)	C <sub>i</sub> (m)
Antenne top			
Antenne o.t.	4,7	34,7	1,5

#### Belastingen mastsectie langsrichting (x-richting) per windrichting

Omschrijving	P <sub>w</sub> [kN/m <sup>2</sup> ]	F <sub>x1</sub> [kN]	F <sub>x2</sub> [kN]	F <sub>x3</sub> [kN]	F <sub>x4</sub> [kN]	h <sub>ef</sub> [m]	M <sub>y1</sub> [kNm]	M <sub>y2</sub> [kNm]	M <sub>y3</sub> [kNm]	M <sub>y4</sub> [kNm]
Broekstuk	0,70	61,7	52,4	0,0	-52,4	7,7	475,5	403,4	0,0	-403,4
Eerste tussenstuk	0,86	27,0	22,9	0,0	-22,9	18,8	507,6	430,7	0,0	-430,7
Tweede tussenstuk	0,94	23,4	19,9	0,0	-19,9	25,4	594,1	504,1	0,0	-504,1
Bovenstuk 1	1,02	30,6	26,0	0,0	-26,0	33,3	1018,5	864,2	0,0	-864,2
Bovenstuk 2	1,10	35,1	29,8	0,0	-29,8	44,7	1567,6	1330,2	0,0	-1330,2
Topstuk	1,15	1,2	1,0	0,0	-1,0	52,3	60,7	51,5	0,0	-51,5
Ondertraverse	0,98	21,8	12,9	0,0	-12,9	29,5	643,5	382,2	0,0	-382,2
Middentraverse	1,06	33,7	20,0	0,0	-20,0	39,1	1316,8	782,2	0,0	-782,2
Boventraverse	1,13	49,3	29,3	0,0	-29,3	49,7	2447,7	1453,9	0,0	-1453,9
<b>Totaal</b>		<b>283,8</b>	<b>214,1</b>	<b>0,0</b>	<b>-214,1</b>		<b>8632,0</b>	<b>6202,4</b>	<b>0,0</b>	<b>-6202,4</b>

#### Belastingen mastsectie dwarsrichting (y-richting) per windrichting

Omschrijving	P <sub>w</sub> [kN/m <sup>2</sup> ]	F <sub>y1</sub> [kN]	F <sub>y2</sub> [kN]	F <sub>y3</sub> [kN]	F <sub>y4</sub> [kN]	h <sub>ef</sub> [m]	M <sub>x1</sub> [kNm]	M <sub>x2</sub> [kNm]	M <sub>x3</sub> [kNm]	M <sub>x4</sub> [kNm]
Broekstuk	0,70	0,0	52,4	61,7	52,4	7,7	0,0	403,4	475,5	403,4
Eerste tussenstuk	0,86	0,0	22,9	27,0	22,9	18,8	0,0	430,7	507,6	430,7
Tweede tussenstuk	0,94	0,0	19,9	23,4	19,9	25,4	0,0	504,1	594,1	504,1
Bovenstuk 1	1,02	0,0	26,0	30,6	26,0	33,3	0,0	864,2	1018,5	864,2
Bovenstuk 2	1,10	0,0	29,8	35,1	29,8	44,7	0,0	1330,2	1567,6	1330,2
Topstuk	1,15	0,0	1,0	1,2	1,0	52,3	0,0	51,5	60,7	51,5
Ondertraverse	0,98	0,0	12,9	8,7	12,9	29,5	0,0	382,2	257,4	382,2
Middentraverse	1,06	0,0	20,0	13,5	20,0	39,1	0,0	782,2	526,7	782,2
Boventraverse	1,13	0,0	29,3	19,7	29,3	49,7	0,0	1453,9	979,1	1453,9
<b>Totaal</b>		<b>0,0</b>	<b>214,1</b>	<b>220,9</b>	<b>214,1</b>		<b>0,0</b>	<b>6202,4</b>	<b>5987,2</b>	<b>6202,4</b>

#### Resulterende belastingen vanuit mastconstructie incl. antenne zonder geleiders niveau fundatie (kar. waarde)

Belasting / windrichting	F <sub>x</sub> [kN]	F <sub>y</sub> [kN]	F <sub>z</sub> [kN]	M <sub>x</sub> [kNm]	M <sub>y</sub> [kNm]	M <sub>z</sub> [kNm]
Permanente belasting	0	0	976	0	0	0
Windrichting 0°	291	0	0	0	8884	0
Windrichting 45°	219	219	0	6381	6381	0
Windrichting 90°	0	228	0	6239	0	0
Windrichting 135°	-219	219	0	6381	-6381	0

Project: RLL-TLB380  
 Tower: HA+0\_c  
 Number: 1188

### Tussenresultaten geleiderbelastingen

#### Geleiders back

Circuit	Geleider	Diameter [mm]	A [mm <sup>2</sup> ]	G [N/m]	E [N/mm <sup>2</sup> ]	$\alpha T$ [-]
Circuit 1	AAAC-AL7 620	32,4	621,0	17,71	56000	2,30E-05
Circuit 2	AAAC-AL7 620	32,4	621,0	17,71	56000	2,30E-05
Circuit 3	AAAC-AL7 620	32,4	621,0	17,71	56000	2,30E-05
Circuit 4	AAAC-AL7 620	32,4	621,0	17,71	56000	2,30E-05
Bliksemdraad 1	AACSR 241-AL3-39-A20SA	21,8	281,0	9,38	70165	1,97E-05
Bliksemdraad 2	OPGW AFL-226/38	21,7	264,0	9,13	72000	1,98E-05

#### Geleiders ahead

Circuit	Geleider	Diameter [mm]	A [mm <sup>2</sup> ]	G [N/m]	E [N/mm <sup>2</sup> ]	$\alpha T$ [-]
Circuit 1	AAAC-AL7 620	32,4	621,0	17,71	56000	2,30E-05
Circuit 2	AAAC-AL7 620	32,4	621,0	17,71	56000	2,30E-05
Circuit 3	AAAC-AL7 620	32,4	621,0	17,71	56000	2,30E-05
Circuit 4	AAAC-AL7 620	32,4	621,0	17,71	56000	2,30E-05
Bliksemdraad 1	AACSR 241-AL3-39-A20SA	21,8	281,0	9,38	70165	1,97E-05
Bliksemdraad 2	OPGW AFL-226/38	21,7	264,0	9,13	72000	1,98E-05

#### Verticale belasting back

Circuit	Bundel [-]	Toeslag [%]	$W_{z,G}$ [N/m]	IJsgebied	Formule	$W_{z,ijs}$ [N/m]	$W_{z,ijs,bundel}$ [N/m]
Circuit 1	4	3	73,0	B	4+0,2d	10,5	41,9
Circuit 2	4	3	73,0	B	4+0,2d	10,5	41,9
Circuit 3	2	3	36,5	B	4+0,2d	10,5	21,0
Circuit 4	2	3	36,5	B	4+0,2d	10,5	21,0
Bliksemdraad 1	1	2	9,6	A	15+0,4d	23,7	23,7
Bliksemdraad 2	1	2	9,3	A	15+0,4d	23,7	23,7

#### Verticale belasting ahead

Circuit	Bundel [-]	Toeslag [%]	$W_{z,G}$ [N/m]	IJsgebied	Formule	$W_{z,ijs}$ [N/m]	$W_{z,ijs,bundel}$ [N/m]
Circuit 1	4	3	73,0	B	4+0,2d	10,5	41,9
Circuit 2	4	3	73,0	B	4+0,2d	10,5	41,9
Circuit 3	2	3	36,5	B	4+0,2d	10,5	21,0
Circuit 4	2	3	36,5	B	4+0,2d	10,5	21,0
Bliksemdraad 1	1	2	9,6	A	15+0,4d	23,7	23,7
Bliksemdraad 2	1	2	9,3	A	15+0,4d	23,7	23,7

#### Isolatoren

Geleider	$G_{isolator}$ [kN]	Aantal	$F_{v,iso}$ [kN]	Lengte [m]	Windopp. [m <sup>2</sup> ]	Windhoogte [m]	Stuwdruk [kN/m <sup>2</sup> ]	Vormfactor	$F_{h,iso}$ [kN]
380ct1f1	3,00	1	3	6,5	1,1	48,50	1,13	1,2	1,49
380ct1f2	3,00	1	3	6,5	1,1	38,50	1,06	1,2	1,40
380ct1f3	3,00	1	3	6,5	1,1	29,00	0,98	1,2	1,29
380ct2f1	3,00	1	3	6,5	1,1	48,50	1,13	1,2	1,49
380ct2f2	3,00	1	3	6,5	1,1	38,50	1,06	1,2	1,40
380ct2f3	3,00	1	3	6,5	1,1	29,00	0,98	1,2	1,29
150ct3f1	2,00	1	2	3,5	0,8	48,50	1,13	1,2	1,08
150ct3f2	2,00	1	2	3,5	0,8	38,50	1,06	1,2	1,02
150ct3f3	2,00	1	2	3,5	0,8	29,00	0,98	1,2	0,94
150ct4f1	2,00	1	2	3,5	0,8	48,50	1,13	1,2	1,08
150ct4f2	2,00	1	2	3,5	0,8	38,50	1,06	1,2	1,02
150ct4f3	2,00	1	2	3,5	0,8	29,00	0,98	1,2	0,94
bl1	0,10	1	0,1	0,2	0,1	53,60	1,16	1,2	0,14
bl2	0,10	1	0,1	0,2	0,1	53,60	1,16	1,2	0,14

Project: RLL-TLB380  
 Tower: HA+0\_c  
 Number: 1188

#### Windbelasting back

Geleider	hoogte		G <sub>c,dwars</sub>	G <sub>c,trek</sub>	C <sub>c</sub>	d <sub>toeslag</sub>	W <sub>y</sub>	W <sub>y,vak</sub>	D <sub>jjs,toeslag</sub>	W <sub>y,ijs</sub>	W <sub>y,ijs,vak</sub>
	wind	Stuwdruk									
	[m]	[kN/m <sup>2</sup> ]	[-]	[-]	[-]	[mm]	[N/m]	[N/m]	[mm]	[N/m]	[N/m]
380ct1f1	50,1	1,14	0,62	0,68	0,96	33,37	89,8	98,8	51,8	174,5	191,9
380ct1f2	40,1	1,07	0,60	0,66	0,98	33,37	84,0	92,4	51,8	159,9	175,9
380ct1f3	30,6	0,99	0,58	0,64	1,00	33,37	77,1	84,9	51,8	143,2	157,6
380ct2f1	50,1	1,14	0,62	0,68	0,96	33,37	89,8	98,8	51,8	174,5	191,9
380ct2f2	40,1	1,07	0,60	0,66	0,98	33,37	84,0	92,4	51,8	159,9	175,9
380ct2f3	30,6	0,99	0,58	0,64	1,00	33,37	77,1	84,9	51,8	143,2	157,6
150ct3f1	50,1	1,14	0,62	0,68	0,96	33,37	44,9	49,4	51,8	87,3	95,9
150ct3f2	40,1	1,07	0,60	0,66	0,98	33,37	42,0	46,2	51,8	79,9	88,0
150ct3f3	30,6	0,99	0,58	0,64	1,00	33,37	38,6	42,4	51,8	71,6	78,8
150ct4f1	50,1	1,14	0,62	0,68	0,96	33,37	44,9	49,4	51,8	87,3	95,9
150ct4f2	40,1	1,07	0,60	0,66	0,98	33,37	42,0	46,2	51,8	79,9	88,0
150ct4f3	30,6	0,99	0,58	0,64	1,00	33,37	38,6	42,4	51,8	71,6	78,8
bl1	55,2	1,17	0,62	0,69	1,18	22,24	19,1	21,0	63,1	55,2	60,6
bl2	55,2	1,17	0,62	0,69	1,18	22,13	19,0	20,9	63,0	55,1	60,5

#### Windbelasting ahead

Geleider	hoogte		G <sub>c,dwars</sub>	G <sub>c,trek</sub>	C <sub>c</sub>	d <sub>toeslag</sub>	W <sub>y</sub>	W <sub>y,vak</sub>	D <sub>jjs,toeslag</sub>	W <sub>y,ijs</sub>	W <sub>y,ijs,vak</sub>
	wind	Stuwdruk									
	[m]	[kN/m <sup>2</sup> ]	[-]	[-]	[-]	[mm]	[N/m]	[N/m]	[mm]	[N/m]	[N/m]
380ct1f1	44,1	1,10	0,61	0,67	0,97	33,37	86,5	95,1	51,8	166,0	182,6
380ct1f2	34,1	1,02	0,59	0,65	0,99	33,37	79,9	87,9	51,8	149,7	164,8
380ct1f3	24,6	0,93	0,56	0,62	1,02	33,37	71,7	78,9	51,8	130,4	143,6
380ct2f1	44,1	1,10	0,61	0,67	0,97	33,37	86,5	95,1	51,8	166,0	182,6
380ct2f2	34,1	1,02	0,59	0,65	0,99	33,37	79,9	87,9	51,8	149,7	164,8
380ct2f3	24,6	0,93	0,56	0,62	1,02	33,37	71,7	78,9	51,8	130,4	143,6
150ct3f1	44,1	1,10	0,61	0,67	0,97	33,37	43,2	47,6	51,8	83,0	91,3
150ct3f2	34,1	1,02	0,59	0,65	0,99	33,37	39,9	43,9	51,8	74,9	82,4
150ct3f3	24,6	0,93	0,56	0,62	1,02	33,37	35,8	39,5	51,8	65,2	71,8
150ct4f1	44,1	1,10	0,61	0,67	0,97	33,37	43,2	47,6	51,8	83,0	91,3
150ct4f2	34,1	1,02	0,59	0,65	0,99	33,37	39,9	43,9	51,8	74,9	82,4
150ct4f3	24,6	0,93	0,56	0,62	1,02	33,37	35,8	39,5	51,8	65,2	71,8
bl1	49,2	1,13	0,62	0,68	1,19	22,24	18,4	20,2	63,1	52,8	58,0
bl2	49,2	1,13	0,62	0,68	1,19	22,13	18,3	20,1	63,0	52,7	57,9

NB: belastingen w<sub>v</sub> gelden voor bundel

Project: RLL-TLB380  
 Masttype: HA+0\_c  
 Mast: 1188

Auteur: TBR  
 Versie: v12.0

**Geleiderbelastingen**

**Uitgangspunten**  
 Betrouwbaarheidsniveau Nieuwbouw CC2  
 Referentieperiode 50 jaar

<b>ULS</b> (bezwijksterkte)		<b>NEN-EN50341-2-15:2019</b>							
Belastingsgeval	omschrijving	Temp °C	$\gamma_G$		$\gamma_Q$			$\gamma_a$ $A_k$	
			$G_{k,mast}$	$G_{k,geleider}$	$Q_{pk}$	$Q_{wk}$	$Q_{ik}$		
ULS 1a	Wind	10°	1,20	1,20	0,00	1,50	0,00	0,0	
ULS 1a_0,9	Wind 0,9Gk alleen mast	10°	0,90	1,20	0,00	1,50	0,00	0,0	
ULS 1a_0,9_0,9	Wind 0,9Gk ook geleider	10°	0,90	0,90	0,00	1,50	0,00	0,0	
ULS 3	Wind+ijs	-5°	1,20	1,20	0,00	0,45	1,50	0,0	
ULS 3_0,9	Wind+ijs 0,9	-5°	0,90	1,20	0,00	0,45	1,50	0,0	
ULS 4	Koude+wind	-20°	1,20	1,20	0,00	0,30	0,00	0,0	
ULS 4_0,9	Koude+wind 0,9	-20°	0,90	1,20	0,00	0,30	0,00	0,0	
ULS 5a	Torsiebelastingen	10°	1,00	1,00	1,00	0,00	0,00	1,0	
ULS 5b	Longitudinale belastingen	10°	1,00	1,00	0,00	0,00	0,00	1,0	
ULS 6	Bouw en onderhoud	5°	1,20	1,20	1,50	0,30	0,00	0,0	
ULS 6_0,9	Bouw en onderhoud	5°	1,20	1,20	0,00	0,30	0,00	0,0	
ULS 7	Permanent	10°	1,35	1,35	0,00	0,00	0,00	0,0	
ULS 8	Special	10°	1,00	1,00	0,00	0,00	0,00	1,0	
<b>SPLS</b> (Bezwijksterkte, enkel voor hoekmasten: afwezigheid geleiders)			$\gamma_G$		$\gamma_Q$			$A_k$	
			$G_k$	$G_k$	$Q_{pk}$	$Q_{wk}$	$Q_{ik}$		
SPLS 1a	Wind	10°	1,20	1,20	0,0	0,78	0,00	0,0	
SPLS 1a_0,9	Wind 0,9	10°	0,90	1,20	0,0	0,78	0,00	0,0	
SPLS 1a_0,9_0,9	Wind 0,9	10°	0,90	0,90	0,0	0,78	0,00	0,0	
SPLS 3	Wind+ijs	-5°	1,20	1,20	0,0	0,36	0,34	0,0	
SPLS 3_0,9	Wind+ijs 0,9	-5°	0,90	1,20	0,0	0,36	0,34	0,0	
SPLS 4	Koude+wind	-20°	1,20	1,20	0,0	0,24	0,00	0,0	
SPLS 4_0,9	Koude+wind 0,9	-20°	0,90	1,20	0,0	0,24	0,00	0,0	
SPLS 6	Bouw en onderhoud	5°	1,20	1,20	1,2	0,24	0,0	0,0	
SPLS 6_0,9	Bouw en onderhoud	5°	1,20	1,20	0,0	0,24	0,0	0,0	
<b>SLS</b> (controle van de vervormingen, vermoeiing, EDS)			$G_k$		$Q_{pk}$	$Q_{wk}$	$Q_{ik}$	$A_k$	
			$G_k$	$G_k$	$Q_{pk}$	$Q_{wk}$	$Q_{ik}$		
SLS 1a	Wind	10°	1,00	1,00	0,0	1,00	0,0	0,0	
SLS 3	Wind+ijs	-5°	1,00	1,00	0,0	0,30	1,00	0,0	
SLS 4	Wind	-20°	1,00	1,00	0,0	0,20	0,0	0,0	
SLS 6	Bouw en onderhoud	5°	1,00	1,00	0,0	0,20	0,0	0,0	
SLS 7	PB (EDS, geen wind)	10°	1,00	1,00	0,0	0,00	0,0	0,0	

Aantal windrichtingen 6  
 Aantal belastingcombinaties ULS 100  
 Aantal belastingcombinaties SPLS 246  
 Aantal belastingcombinaties SLS 15  
 Aantal knooplasten 12274

Project: RLL-TLB380  
 Masttype: HA+0\_c  
 Mast: 1188

### Samenvattingstabellen geleiderbelastingen

In de onderstaande vier tabellen is weergegeven:

- De maximale geleiderbelasting in het globale assenstelsel, gesplitst in aandeel van back en ahead span
- De gecombineerde geleiderbelasting (Ba+Ah) in het globale assenstelsel met in het lokale assenstelsel de maximaal optredende trekkracht. Componenten Fx en Fy als absolute waarde
- De alledaagse (EDS) waarden van de gecombineerde geleiderbelastingen (Ba+Ah) met bijbehorende trekkrachten
- Controle op uplift, waar een negatieve waarde duidt op uplift

#### Maximale waarden voor back en ahead span

Geleider	Fx_ba [kN]	Fx_ah [kN]	Fy_ba [kN]	Fy_ah [kN]	Fz_ba [kN]	Fz_ah [kN]
bl1	-65,7	65,2	16,7	16,4	11,1	11,0
380ct1f1	-264,6	262,4	73,5	71,6	39,8	39,7
380ct1f2	-260,9	258,4	70,2	67,8	39,7	39,6
380ct1f3	-256,9	254,1	66,2	63,1	39,6	39,5
Post-isolato	0,0	0,0	0,0	0,0	0,0	
Post-isolato	0,0	0,0	0,0	0,0	0,0	
Post-isolato	0,0	0,0	0,0	0,0	0,0	
380ct2f1	-264,6	262,4	73,5	71,6	39,8	39,7
380ct2f2	-260,9	258,4	70,2	67,8	39,7	39,6
380ct2f3	-256,9	254,1	66,2	63,1	39,6	39,5
150ct3f1	-132,3	131,2	37,3	36,3	21,3	21,3
150ct3f2	-130,4	129,2	35,6	34,4	21,3	21,3
150ct3f3	-128,4	127,0	33,6	32,1	21,3	21,3
150ct4f1	-132,3	131,2	37,3	36,3	21,3	21,3
150ct4f2	-130,4	129,2	35,6	34,4	21,3	21,3
150ct4f3	-128,4	127,0	33,6	32,1	21,3	21,3
bl2	-64,8	64,3	16,5	16,2	11,0	10,9
Post-isolato	0,0	0,0	0,0	0,0	0,0	
Post-isolato	0,0	0,0	0,0	0,0	0,0	
Post-isolato	0,0	0,0	0,0	0,0	0,0	

#### Min. Weight span (m)

Geleider	SLS 1a	SLS 4	SLS 7
Weight spar Combinatie1			
bl1	481,1	498,0	481,0
380ct1f1	481,1	496,4	481,0
380ct1f2	481,0	496,2	481,0
380ct1f3	481,0	495,8	481,0
Post-isolator 1			
Post-isolator 2			
Post-isolator 3			
380ct2f1	481,1	496,4	481,0
380ct2f2	481,0	496,2	481,0
380ct2f3	481,0	495,8	481,0
150ct3f1	481,1	496,4	481,0
150ct3f2	481,0	496,2	481,0
150ct3f3	481,0	495,8	481,0
150ct4f1	481,1	496,4	481,0
150ct4f2	481,0	496,2	481,0
150ct4f3	481,0	495,8	481,0
bl2	481,1	498,3	481,0
Post-isolator 4			
Post-isolator 5			
Post-isolator 6			

#### Max. Weight span (m)

Geleider	ULS 1a	ULS 3
Weight spar Combinatie1		
bl1	575,0	464,1
380ct1f1	529,0	480,4
380ct1f2	524,0	479,3
380ct1f3	518,0	478,0
Post-isolator 1		
Post-isolator 2		
Post-isolator 3		
380ct2f1	529,0	480,4
380ct2f2	524,0	479,3
380ct2f3	518,0	478,0
150ct3f1	529,0	480,4
150ct3f2	524,0	479,3
150ct3f3	518,0	478,0
150ct4f1	529,0	480,4
150ct4f2	524,0	479,3
150ct4f3	518,0	478,0
bl2	577,5	463,7
Post-isolator 4		
Post-isolator 5		
Post-isolator 6		

Omhullende weight span over alle combinaties (incl. 0,9 combinaties)

Wind / Weight span verhouding	Wind / Weight span verhouding
Max. weight span	575,0 m
Min. weight span	93,3 m
	1,437 -
	0,233 -

Project: RLL-TLB380  
 Masttype: HA+0\_c  
 Mast: 1188

**Maximale waarden back+ahead span**

Geleider	Maximale waarden back+ahead span		Maximale waarden trekkracht geleider		
	Fx [kN]	Fy [kN]	Fz [kN]	Ft_ba [kN]	Ft_ah [kN]
bl1	38,7	32,7	11,1	-67,6	67,1
380ct1f1	205,8	141,9	39,8	-271,5	269,2
380ct1f2	201,9	135,0	39,7	-267,5	264,9
380ct1f3	197,6	126,6	39,6	-263,3	260,2
Post-isolato	4,2	4,2	6,8	0,0	
Post-isolato	3,2	3,2	4,7	0,0	
Post-isolato	4,9	4,9	6,8	0,0	
380ct2f1	205,8	141,9	39,8	-271,5	269,2
380ct2f2	201,9	135,0	39,7	-267,5	264,9
380ct2f3	197,6	126,6	39,6	-263,3	260,2
150ct3f1	108,3	71,9	21,3	-135,8	134,6
150ct3f2	108,2	68,5	21,3	-133,8	132,4
150ct3f3	108,1	64,3	21,3	-131,6	130,1
150ct4f1	108,3	71,9	21,3	-135,8	134,6
150ct4f2	108,2	68,5	21,3	-133,8	132,4
150ct4f3	108,1	64,3	21,3	-131,6	130,1
bl2	38,2	32,3	11,0	-66,7	66,1
Post-isolato	4,2	4,2	6,8	0,0	
Post-isolato	3,2	3,2	4,7	0,0	
Post-isolato	4,9	4,9	6,8	0,0	

**EDS-belastingen geleiders**

Geleider	EDS-belastingen geleiders		Controlle uplift SLS-wind		
	Fx [kN]	Fy [kN]	Fz [kN]	Ft_ba [kN]	Ft_ah [kN]
bl1	17,0	3,0	2,4	-17,2	17,2
380ct1f1	129,3	22,8	20,5	-131,3	131,3
380ct1f2	129,3	22,8	20,5	-131,3	131,3
380ct1f3	129,3	22,8	20,5	-131,3	131,3
Post-isolato	0,0	0,0	5,0	0,0	
Post-isolato	0,0	0,0	3,5	0,0	
Post-isolato	0,0	0,0	5,0	0,0	
380ct2f1	129,3	22,8	20,5	-131,3	131,3
380ct2f2	129,3	22,8	20,5	-131,3	131,3
380ct2f3	129,3	22,8	20,5	-131,3	131,3
150ct3f1	64,7	11,4	10,8	-65,7	65,7
150ct3f2	64,7	11,4	10,8	-65,7	65,7
150ct3f3	64,7	11,4	10,8	-65,7	65,7
150ct4f1	64,7	11,4	10,8	-65,7	65,7
150ct4f2	64,7	11,4	10,8	-65,7	65,7
150ct4f3	64,7	11,4	10,8	-65,7	65,7
bl2	16,5	2,9	2,3	-16,8	16,8
Post-isolato	0,0	0,0	5,0	0,0	
Post-isolato	0,0	0,0	3,5	0,0	
Post-isolato	0,0	0,0	5,0	0,0	

**Controlle uplift SLS-wind**

Combinatie: Geleider	Controlle uplift SLS-wind	
	Fz_ba [kN]	Fz_ah [kN]
SLS 4 bl1	0,0	0,0
380ct1f1	0,0	0,0
380ct1f2	0,0	0,0
380ct1f3	0,0	0,0
Post-isolato	0,0	
Post-isolato	0,0	
Post-isolato	0,0	
380ct2f1	0,0	0,0
380ct2f2	0,0	0,0
380ct2f3	0,0	0,0
150ct3f1	0,0	0,0
150ct3f2	0,0	0,0
150ct3f3	0,0	0,0
150ct4f1	0,0	0,0
150ct4f2	0,0	0,0
150ct4f3	0,0	0,0
bl2	0,0	0,0
Post-isolato	0,0	
Post-isolato	0,0	
Post-isolato	0,0	

Project: RLL-TLB380  
 Masttype: HA+0\_c  
 Mast: 1188

**ULS-fundatiebelasting combinatie 1 en 3 wind haaks op de lijn of bissectrice en EDS, vanuit geleiders**

Combinatie	Combination	$F_x$ [kN]	$F_y$ [kN]	$F_z$ [kN]	$M_x$ [kNm]	$M_y$ [kNm]	$M_z$ [kNm]
ULS 1a_90		-59	1294	531	50645	-2205	0
ULS 1a_0,9_0		27	490	336	18910	1051	0
ULS 1a_0,9_0,9_90		-65	1252	193	49061	-2426	0
ULS 3_0		9	806	788	31398	343	0
SLS 7		0	422	412	16292	0	0

**ULS-fundatiebelasting combinatie 1 en 3 wind haaks op de lijn of bissectrice en EDS, totaal geleiders en mast**

Combinatie	$F_x$ [kN]	$F_y$ [kN]	$F_z$ [kN]	$M_x$ [kNm]	$M_y$ [kNm]	$M_z$ [kNm]
ULS 1a_90	-59	1636	1702	60003	-2205	0
ULS 1a_0,9_0,9_90	-65	1595	1072	58419	-2426	0
SLS 7	0	422	1389	16292	0	0

**Fundatiebelastingen, selectie belastingcombinaties op basis grootste waarde**

Combinatie	$F_x$ [kN]	$F_y$ [kN]	$F_z$ [kN]	$M_x$ [kNm]	$M_y$ [kNm]	$M_z$ [kNm]
ULS 1a_0,9_90	-59	1636	1164	<b>60004</b>	-2205	0
SPLS 3_80 Ah All Cts	-1877	491	1509	18181	<b>-73179</b>	9
SPLS 3_80 Ba Ct1	895	666	1623	26158	34591	<b>-9703</b>
SPLS 3_0,9_80 Ah All Cts	-1877	491	1077	<b>18181</b>	<b>-73179</b>	9

*Noot: grootste waarden kunnen in meerdere combinaties voorkomen, een combinatie is weergegeven.*

**Oplegreacties op fundering per randstijl**

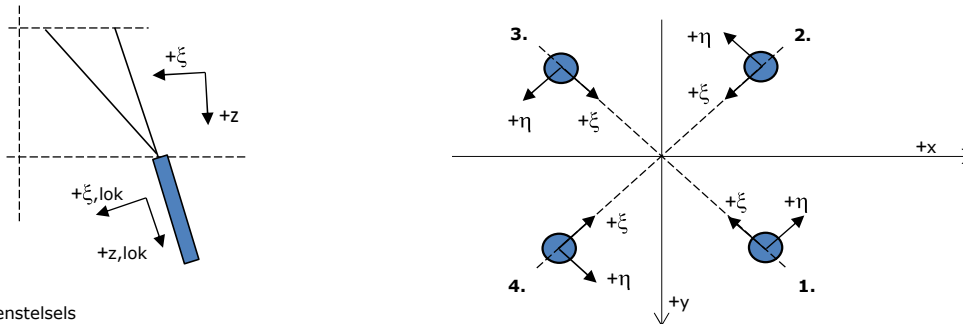

Assenstelsels

**Maximale drukbelasting**

Stijl	Combinatie	$R_x$ [kN]	$R_y$ [kN]	$R_z$ [kN]	$R_\eta$ [kN]	$R_\xi$ [kN]	$R_{\xi,lok}$ [kN]	$R_{z,lok}$ [kN]
1	SPLS 3_100 Ba All Cts	701	842	<b>4207</b>	-100	-1090	40	4357
2	ULS 8 Ah	417	-613	<b>2793</b>	138	-728	22	2892
3	ULS 8 Ba	-417	-613	<b>2793</b>	-138	-728	22	2892
4	SPLS 3_80 Ah All Cts	-709	852	<b>4261</b>	101	-1104	41	4412

**Maximale trekbelasting**

Stijl	Combinatie	$R_x$ [kN]	$R_y$ [kN]	$R_z$ [kN]	$R_\eta$ [kN]	$R_\xi$ [kN]	$R_{\xi,lok}$ [kN]	$R_{z,lok}$ [kN]
1	SPLS 3_0,9_90 Ah All Cts	-254	-472	<b>-2074</b>	154	513	-44	-2148
2	SPLS 3_0,9_80 Ah All Cts	-575	717	<b>-3614</b>	-100	913	-58	-3743
3	SPLS 3_0,9_100 Ba All Cts	563	703	<b>-3547</b>	99	895	-58	-3672
4	SPLS 3_0,9_0 Ba All Cts	284	-469	<b>-2112</b>	-131	532	-35	-2187

**Maximale torsiebelasting (positief)**

Stijl	Combinatie	$R_x$ [kN]	$R_y$ [kN]	$R_z$ [kN]	$R_\eta$ [kN]	$R_\xi$ [kN]	$R_{\xi,lok}$ [kN]	$R_{z,lok}$ [kN]
1	SPLS 3_90 Ah Ct1	285	-277	-38	<b>398</b>	-6	-16	-39
2	SPLS 3_0,9_90 Ba Ct2	-134	-415	758	<b>388</b>	-199	5	785
3	SPLS 3_90 Ba Ct2	154	605	-2133	<b>319</b>	536	-37	-2209
4	SPLS 3_0,9_90 Ah Ct1	-329	761	2979	<b>305</b>	-771	29	3084

**Maximale torsiebelasting (negatief)**

Index	Combinatie	$R_x$ [kN]	$R_y$ [kN]	$R_z$ [kN]	$R_\eta$ [kN]	$R_\xi$ [kN]	$R_{\xi,lok}$ [kN]	$R_{z,lok}$ [kN]
1	SPLS 3_0,9_90 Ba Ct1	315	752	2909	<b>-309</b>	-755	27	3012
2	SPLS 3_90 Ah Ct2	-166	615	-2198	<b>-317</b>	553	-38	-2276
3	SPLS 3_0,9_90 Ah Ct2	122	-422	817	<b>-385</b>	-212	7	846
4	SPLS 3_90 Ba Ct1	-296	-268	15	<b>-399</b>	-19	-15	16



Project: RLL-TLB380  
 Masttype: HA+0\_c  
 Mast: 1188

#### Combinatie Ftrek+Fhor

Stijl	Combinatie	R <sub>x</sub> [kN]	R <sub>y</sub> [kN]	R <sub>z</sub> [kN]	R <sub>η</sub> [kN]	R <sub>ξ</sub> [kN]	R <sub>ξ,lok</sub> [kN]	R <sub>z,lok</sub> [kN]
1	SPLS 3_0,9_90 Ah All Cts	-254	-472	<b>-2074</b>	<b>154</b>	513	-44	-2148
2	SPLS 3_0,9_80 Ah All Cts	-575	717	<b>-3614</b>	<b>-100</b>	913	-58	-3743
3	SPLS 3_0,9_100 Ba All Cts	563	703	<b>-3547</b>	<b>99</b>	895	-58	-3672
4	SPLS 3_0,9_0 Ba All Cts	284	-469	<b>-2112</b>	<b>-131</b>	532	-35	-2187

#### Permanente belasting

Stijl	Combinatie	R <sub>x</sub> [kN]	R <sub>y</sub> [kN]	R <sub>z</sub> [kN]	R <sub>η</sub> [kN]	R <sub>ξ</sub> [kN]	R <sub>ξ,lok</sub> [kN]	R <sub>z,lok</sub> [kN]
1	SLS 7	217	178	1040	28	-280	0	1077
2	SLS 7	-72	33	-345	28	74	-18	-358
3	SLS 7	72	33	-345	-28	74	-18	-358
4	SLS 7	-217	178	1040	-28	-280	0	1077

#### Omhullenden ongeacht stijl

Belasting	Combinatie	R <sub>x</sub> [kN]	R <sub>y</sub> [kN]	R <sub>z</sub> [kN]	R <sub>η</sub> [kN]	R <sub>ξ</sub> [kN]	R <sub>ξ,lok</sub> [kN]	R <sub>z,lok</sub> [kN]
Max. druk	SPLS 3_80 Ah All Cts	-709	852	<b>4261</b>	101	-1104	41	4412
Max. trek	SPLS 3_0,9_80 Ah All Cts	-575	717	<b>-3614</b>	-100	913	-58	-3743
Max. pos. torsie	SPLS 3_90 Ah Ct1	285	-277	-38	<b>398</b>	-6	-16	-39
Max. neg. torsie	SPLS 3_90 Ba Ct1	-296	-268	15	<b>-399</b>	-19	-15	16
Comb. trek+torsie	SPLS 3_0,9_80 Ah All Cts	-575	717	<b>-3614</b>	<b>-100</b>	913	-58	-3743

#### Maximale trekbelasting SLS

Stijl	Combinatie	R <sub>x</sub> [kN]	R <sub>y</sub> [kN]	R <sub>z</sub> [kN]	R <sub>η</sub> [kN]	R <sub>ξ</sub> [kN]	R <sub>ξ,lok</sub> [kN]	R <sub>z,lok</sub> [kN]
1	SPLS 3_0,9_80 Ah All Cts	-251	-471	<b>-2069</b>	156	511	-45	-2142
2	SPLS 3_0,9_80 Ah All Cts	-575	717	<b>-3614</b>	-100	913	-58	-3743
3	SPLS 1a_0,9_100 Ba Ct2	231	609	<b>-2340</b>	267	594	-35	-2423
4	SPLS 3_0,9_100 Ba Ct2	151	108	<b>-197</b>	184	30	-22	-204

#### Maximale drukbelasting SLS

Stijl	Combinatie	R <sub>x</sub> [kN]	R <sub>y</sub> [kN]	R <sub>z</sub> [kN]	R <sub>η</sub> [kN]	R <sub>ξ</sub> [kN]	R <sub>ξ,lok</sub> [kN]	R <sub>z,lok</sub> [kN]
1	SPLS 1a_100 Ba Ct2	722	398	<b>2999</b>	230	-792	14	3105
2	SPLS 3_100 Ba Ct2	-98	-440	<b>927</b>	380	-242	7	960
3	SPLS 3_80 Ah All Cts	-387	-606	<b>2715</b>	-155	-702	28	2811
4	SPLS 3_80 Ah All Cts	-709	852	<b>4261</b>	101	-1104	41	4412

Project: RLL-TLB380  
Masttype: HA+0\_c  
Mast: 1188



Project: RLL-TLB380  
Tower: HA+3\_c  
Number: 1094

Auteur: TBR  
Versie: v12.0

### Geleiderbelastingen

#### Algemeen

Benaming HA+3\_c  
Masttype Hoekmast  
Aantal circuits 4  
Configuratie 4-circuit-dubbel verticaal  
Aantal bliksemgeleiders 2

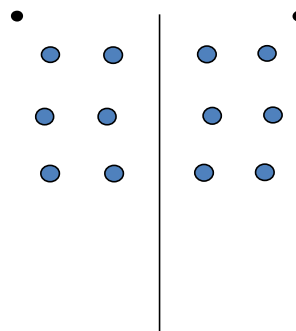

Configuratie geleiders

#### Uitgangspunten

Norm NEN-EN50341-2-15:2019  
Gevolgklasse initieel CC2  
Betrouwbaarheidsniveau initieel Nieuwbouw  
Referentieperiode initieel 50 jaar  
Betrouwbaarheidsniveau na aanpassing n.v.t.  
50 jaar  
Windgebied III  
Windsnelheid (m/s) 24,5 m/s  
Terreincategorie II  
Reductiefactor  $C_{dir}$  1,00  
IJSgebied fasegeleider B  
IJSgebied bliksemgeleider A

#### Geleiders Back

Omschrijving	Spanning	Geleider Back	Bundel Ba	IJSgebied	Toeslag gewicht	Toeslag diameter	Intrekwaarden $P_{back}$
Circuit 1	380 kV	AAAC-AL7 620	4	B	3 %	3 %	1800
Circuit 2	380 kV	AAAC-AL7 620	4	B	3 %	3 %	1800
Circuit 3	150 kV	AAAC-AL7 620	2	B	3 %	3 %	1800
Circuit 4	150 kV	AAAC-AL7 620	2	B	3 %	3 %	1800
Bliksemdraad 1		AACSR 241-AL3-39-A20SA	1	A	2 %	2 %	1800
Bliksemdraad 2		OPGW AFL-226/38	1	A	2 %	2 %	1800

#### Geleiders Ahead

Omschrijving	Spanning	Geleider Ahead	Bundel Ah	IJSgebied	Toeslag gewicht	Toeslag diameter	Intrekwaarden $P_{ahead}$
Circuit 1	380 kV	AAAC-AL7 620	4	B	3 %	3 %	1800
Circuit 2	380 kV	AAAC-AL7 620	4	B	3 %	3 %	1800
Circuit 3	150 kV	AAAC-AL7 620	2	B	3 %	3 %	1800
Circuit 4	150 kV	AAAC-AL7 620	2	B	3 %	3 %	1800
Bliksemdraad 1		AACSR 241-AL3-39-A20SA	1	A	2 %	2 %	1800
Bliksemdraad 2		OPGW AFL-226/38	1	A	2 %	2 %	1800

#### Isolatoren (1)

Omschrijving	Ophanging	Gewicht [kN]	Lengte [m]	Windopp. [m <sup>2</sup> ]
Circuit 1	Afspanketting	3,00	6,50	2,20
Circuit 2	Afspanketting	3,00	6,50	2,20
Circuit 3	Afspanketting	2,00	4,50	1,00
Circuit 4	Afspanketting	2,00	4,50	1,00
Bliksemdraad 1	Afspanketting	0,10	0,20	0,10
Bliksemdraad 2	Afspanketting	0,10	0,20	0,10

1. Eigenschappen gelden voor geheel van de isolatorset

#### Ophanghoogte en positie in mast

Circuits	Aanduiding	Nummer	Ophanghoogte	Aangrijppunt	Positie in mast Horizontale afstand
Circuit 1	10	380ct1f1	51,0 m	51,0 m	-10,8 m
Circuit 1	11	380ct1f2	41,0 m	41,0 m	-14,3 m
Circuit 1	12	380ct1f3	31,5 m	31,5 m	-11,4 m
Circuit 2	40	380ct2f1	51,0 m	51,0 m	10,8 m
Circuit 2	41	380ct2f2	41,0 m	41,0 m	14,3 m
Circuit 2	42	380ct2f3	31,5 m	31,5 m	11,4 m
Circuit 3	20	150ct3f1	51,0 m	51,0 m	-4,3 m
Circuit 3	21	150ct3f2	41,0 m	41,0 m	-7,8 m
Circuit 3	22	150ct3f3	31,5 m	31,5 m	-4,9 m
Circuit 4	30	150ct4f1	51,0 m	51,0 m	4,3 m
Circuit 4	31	150ct4f2	41,0 m	41,0 m	7,8 m
Circuit 4	32	150ct4f3	31,5 m	31,5 m	4,9 m
Bliksemdraad 1	1	bl1	56,1 m	56,1 m	-16,2 m
Bliksemdraad 2	3	bl2	56,1 m	56,1 m	16,2 m

Project: RLL-TLB380  
 Tower: HA+3\_c  
 Number: 1094

**Hoogteaanpassing naastgelegen masten** (aanpassing wind- en weight span)

	Back	Ahead	
Verhoging voor windbelasting	15,0 m	6,0 m	(positief: omhoog)
Verlaging voor verticale belasting	-6,0 m	-6,0 m	(negatief: omlaag, grotere weight span)
Verlaging:	Niet in 0,9EG-combinaties		

**Hoogteafwijking mastbeeld naastgelegen masten en richtingsverandering t.o.v. Lijnrichting**

Circuits	Aanduiding	Nummer	Hoogteverschil		Richtingsverandering	
			$\Delta h$ back	$\Delta h$ ahead	$\Delta y$ back	$\Delta y$ ahead
Circuit 1	10	380ct1f1	0,0	0,0 m	0,0	0,0 m
Circuit 1	11	380ct1f2	0,0	0,0 m	0,0	0,0 m
Circuit 1	12	380ct1f3	0,0	0,0 m	0,0	0,0 m
Circuit 2	40	380ct2f1	0,0	0,0 m	0,0	0,0 m
Circuit 2	41	380ct2f2	0,0	0,0 m	0,0	0,0 m
Circuit 2	42	380ct2f3	0,0	0,0 m	0,0	0,0 m
Circuit 3	20	150ct3f1	0,0	0,0 m	0,0	0,0 m
Circuit 3	21	150ct3f2	0,0	0,0 m	0,0	0,0 m
Circuit 3	22	150ct3f3	0,0	0,0 m	0,0	0,0 m
Circuit 4	30	150ct4f1	0,0	0,0 m	0,0	0,0 m
Circuit 4	31	150ct4f2	0,0	0,0 m	0,0	0,0 m
Circuit 4	32	150ct4f3	0,0	0,0 m	0,0	0,0 m
Bliksemdraad 1	1	bl1	0,0	0,0 m	0,0	0,0 m
Bliksemdraad 2	3	bl2	0,0	0,0 m	0,0	0,0 m

**Lijn- en mastgegevens**

	Back	Ahead
Ruling span $\sqrt{(\Sigma L^3)/\Sigma L}$	400,0	400,0 m
Lijnhoek $\beta$	160 °	
Rotatie mast t.o.v. bissectrice $\theta$	0 °	
Vaklengte	400	400 m
Hoogte onderkant mast t.o.v. maaiveld	0,5 m	
Beschouwde windrichtingen	$\alpha_1$	0 °
Windrichtingen volgens:	$\alpha_2$	45 °
Geleiderbelastingen	$\alpha_3$	90 °
	$\alpha_4$	135 °
	$\alpha_5$	80 °
	$\alpha_6$	100 °

Windrichtingen gelden t.o.v. hoofdrichting mastconstructie, niet t.o.v. bissectrice.

Windrichtingen en positieve richtingen belastingen

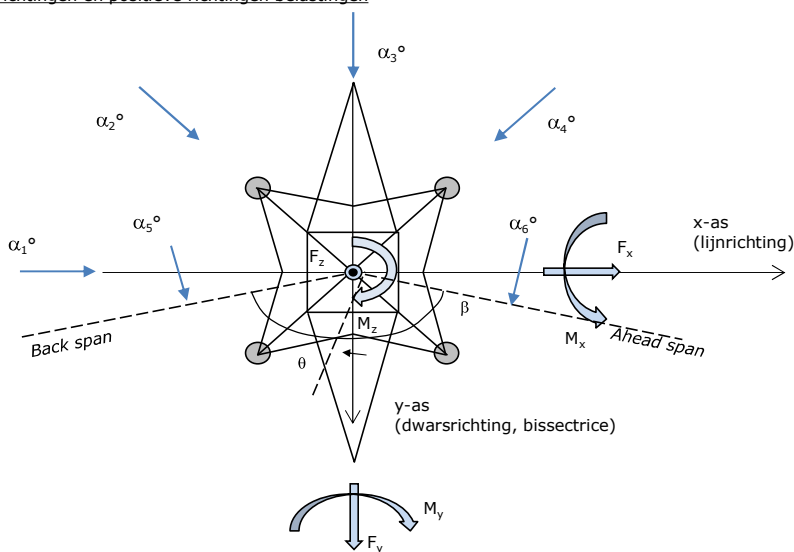

**Beschouwd aantal windrichtingen**

1a	6
3	6
4	1
6	1
Overig	1

Project: RLL-TLB380  
 Tower: HA+3\_c  
 Number: 1094

### Geleiderafval

		SPLS - torsie		SPLS - Enkelzijdige trek		5a - geleiderbreuk	
		Aanw.	Afw.	Aanw.	Afw.	Aanw.	Afw.
Circuit 1	380ct1f1	1	0	1	0	1	0
Circuit 1	380ct1f2	1	0	1	0	1	0
Circuit 1	380ct1f3	1	0	1	0	1	0
Circuit 2	380ct2f1	0	1	1	0	1	0
Circuit 2	380ct2f2	0	1	1	0	1	0
Circuit 2	380ct2f3	0	1	1	0	1	0
Circuit 3	150ct3f1	1	0	1	0	1	0
Circuit 3	150ct3f2	1	0	1	0	1	0
Circuit 3	150ct3f3	1	0	1	0	1	0
Circuit 4	150ct4f1	0	1	1	0	1	0
Circuit 4	150ct4f2	0	1	1	0	1	0
Circuit 4	150ct4f3	0	1	1	0	1	0
Bliksemdraad 1	b11	1	0	1	0	1	0
Bliksemdraad 2	b12	0	1	1	0	1	0

### Belastingssituaties SPLS

Beschouwde situaties SPLS: 1 t/m 6, alle mogelijke situaties.

Principe belastingssituaties:

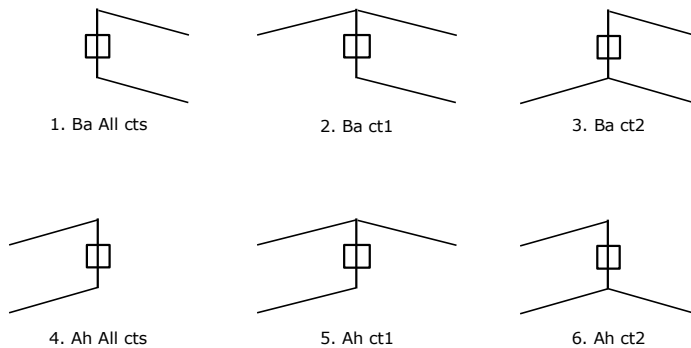

### Belastingssituaties 5a. Geleiderbreuk

Beschouwde situaties geleiderbreuk 5a: 1 en 2, alle mogelijke situaties.

Principe belastingssituaties:

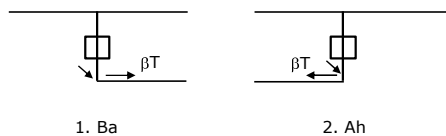

Project: RLL-TLB380  
 Tower: HA+3\_c  
 Number: 1094

### Belastingsituaties 6. Bouw- en onderhoud

Onder 6a wordt de belasting door aanwezigheid lijnwagen of lijnfiets in combinatie met puntlast op traverse in rekening gebracht. Combinatie 6b bevat geen belastingen in geleider of op traverse. Deze combinatie is toegevoegd om te kunnen combineren met separate controle bordessen etc. De situaties worden in ULS en in iedere SPLS-situatie (in geval van hoekmast) toegepast.

	Fase	Bliksem
Lijnwagen	4,0 kN	2,0 kN
Puntlast op traverse	1,0 kN	1,0 kN

Beschouwde situaties bouw- en onderhoud 6a: 1 t/m 4, alle mogelijke situaties.

Aanwezigheid lijnwagen: Circuit, belasting tegelijk aanwezig in alle geleiders per circuit.

Principe belastingssituaties:

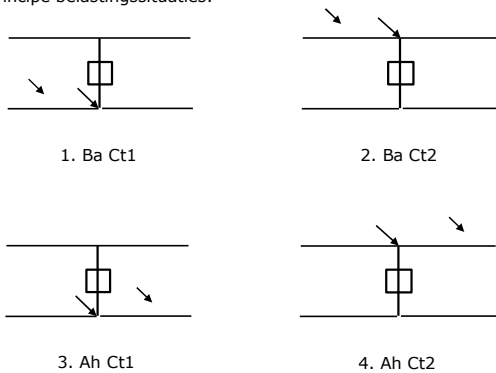

### Belastingsituaties 8. Lijndansen als statische belasting

Geleider		
Steunmast fase	0,866 W	1,5 W
Steunmast bliksem	1,5 EDS	1,5 W
Hoekmast fase en bliksem	1,5 EDS	1,5 W

Beschouwde situaties lijndansen 8: 1 en 2, alle mogelijke situaties.

Belasting tegelijk aanwezig in alle geleiders van het circuit.

Principe belastingssituaties:

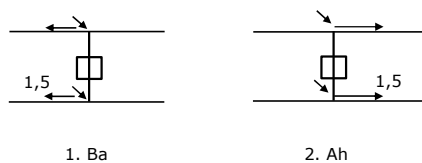

### Belastingcombinatie 8. Lijndansen als dynamische belasting

Alleen van toepassing op hoek- en eindmasten

Belasting bestaat uit EDS-trekbelasting in één van de geleiders aan één zijde van de mast

Door gebruiker via het belastingsspectrum van tabel 4.11/NL.1 om te zetten naar spanningspectrum

Project: RLL-TLB380  
 Tower: HA+3\_c  
 Number: 1094

## Mastconstructie

### Eigenschappen

Masttype	Hoekmast	
Mastbenaming	HA+3_c	
Voetplaat t.o.v. maaiveld	0,5 m	
Masthoogte t.o.v. voetplaat	56,1 m	
Gewicht mast	1049,8 kN	
<i>Breedte en helling mast bij fundatie</i>	x-ri.	y-ri.
Pootsprei	12,90	12,90 m
Helling van de randstijl	0,190	0,190 -
Factor spatkracht	1,1	1,1 -

### Berekening windbelasting

Dynamische invloed $G_T$	1,00 (Masthoogte < 60 m)
Windbelasting overhoeks op mastlichaam evenredig met:	$(A1C1\sin^2(\phi)+A2C2\cos^2(\phi))$
Windbelasting overhoeks op traverse evenredig met:	$(A1C1\sin^2(\phi)+A2C2\cos^2(\phi))$
Vergroting wind overhoeks mastlichaam	$(1+0,2\sin^2(2\phi))$
Vergroting wind overhoeks traverse	$(1+0,2\sin^2(2\phi))$
Factor wind evenwijdig t.o.v. haaks op traverse	0,4

### Eigenschappen mastsecties langsrichting (vooraanzicht, yz-vlak)

Omschrijving	h [m]	b <sub>1</sub> [m]	b <sub>2</sub> [m]	Δh [m]	Δ <sub>x</sub> [m]	A <sub>0</sub> [m <sup>2</sup> ]	A <sub>1</sub> [m <sup>2</sup> ]	χ = A <sub>1</sub> /A <sub>0</sub> [-]	C <sub>t</sub>
Broekstuk	18,40	12,90	5,91	18,40	0,190	173,07	39,79	0,23	2,80
Eerste tussenstuk	25,20	5,91	5,23	6,80	0,050	37,88	13,24	0,35	2,37
Tweede tussenstuk	31,50	5,23	4,60	6,30	0,050	30,96	10,25	0,33	2,43
Bovenstuk 1	41,00	4,60	3,65	9,50	0,050	39,19	11,88	0,30	2,52
Bovenstuk 2	54,40	3,65	2,31	13,40	0,050	39,93	13,01	0,33	2,45
Topstuk	56,10	2,31		1,70		1,96	0,33	0,17	3,08
Ondertraverse	31,50	9,40		3,10		14,57	4,37	0,30	2,54
Middentraverse	41,00	12,78		3,20		20,45	6,34	0,31	2,50
Boventraverse	51,00	14,88		5,10		37,93	7,34	0,19	2,96

### Eigenschappen mastsecties dwarsrichting (zijaanzicht, xz-vlak)

Omschrijving	h [m]	b <sub>1</sub> [m]	b <sub>2</sub> [m]	Δh [m]	Δ <sub>x</sub> [m]	A <sub>0</sub> [m <sup>2</sup> ]	A <sub>1</sub> [m <sup>2</sup> ]	χ = A <sub>1</sub> /A <sub>0</sub> [-]	C <sub>t</sub>
Broekstuk	18,40	12,90	5,91	18,40	0,190	173,07	39,79	0,23	2,80
Eerste tussenstuk	25,20	5,91	5,23	6,80	0,050	37,88	13,24	0,35	2,37
Tweede tussenstuk	31,50	5,23	4,60	6,30	0,050	30,96	10,25	0,33	2,43
Bovenstuk 1	41,00	4,60	3,65	9,50	0,050	39,19	11,88	0,30	2,52
Bovenstuk 2	54,40	3,65	2,31	13,40	0,050	39,93	13,01	0,33	2,45
Topstuk	56,10	2,31		1,70		1,96	0,33	0,17	3,08
Ondertraverse	31,50	9,40		3,10		14,57	4,37	0,30	2,54
Middentraverse	41,00	12,78		3,20		20,45	6,34	0,31	2,50
Boventraverse	51,00	14,88		5,10		37,93	7,34	0,19	2,96

NB: oppervlakte traverse dwarsrichting van de tabel wordt in berekening gereduceerd.  
 NB: oppervlakte traverse per zijde, dus helft van totaal van twee traveres.



Project: RLL-TLB380  
 Tower: HA+3\_c  
 Number: 1094

#### Windoppervlak feeders telecominstallaties

Onderdeel	A (m <sup>2</sup> /m)	Factor	Δh	A <sub>1</sub>
Broekstuk	0,14	0,71	18,4	1,8
Eerste tussenstuk	0,14	0,71	6,8	0,7
Tweede tussenstuk	0,14	0,71	6,3	0,6
Bovenstuk 1	0,14	0,71	9,5	0,9
Bovenstuk 2				

#### Invoer antennes

Omschrijving	A (m <sup>2</sup> )	h (m)	C <sub>i</sub> (m)
Antenne top			
Antenne o.t.	4,7	37,7	1,5

#### Belastingen mastsectie langsrichting (x-richting) per windrichting

Omschrijving	P <sub>w</sub> [kN/m <sup>2</sup> ]	F <sub>x1</sub> [kN]	F <sub>x2</sub> [kN]	F <sub>x3</sub> [kN]	F <sub>x4</sub> [kN]	h <sub>ef</sub> [m]	M <sub>y1</sub> [kNm]	M <sub>y2</sub> [kNm]	M <sub>y3</sub> [kNm]	M <sub>y4</sub> [kNm]
Broekstuk	0,70	78,2	66,4	0,0	-66,4	9,2	719,6	610,6	0,0	-610,6
Eerste tussenstuk	0,90	28,2	24,0	0,0	-24,0	21,8	615,6	522,3	0,0	-522,3
Tweede tussenstuk	0,97	24,2	20,5	0,0	-20,5	28,4	686,2	582,3	0,0	-582,3
Bovenstuk 1	1,05	31,4	26,6	0,0	-26,6	36,3	1136,7	964,5	0,0	-964,5
Bovenstuk 2	1,12	35,7	30,3	0,0	-30,3	47,7	1701,8	1444,0	0,0	-1444,0
Topstuk	1,17	1,2	1,0	0,0	-1,0	55,3	65,2	55,3	0,0	-55,3
Ondertraverse	1,01	22,4	13,3	0,0	-13,3	32,5	728,4	432,7	0,0	-432,7
Middentraverse	1,08	34,4	20,4	0,0	-20,4	42,1	1446,5	859,2	0,0	-859,2
Boventraverse	1,15	50,0	29,7	0,0	-29,7	52,7	2635,4	1565,3	0,0	-1565,3
<b>Totaal</b>		<b>305,7</b>	<b>232,2</b>	<b>0,0</b>	<b>-232,2</b>		<b>9735,3</b>	<b>7036,1</b>	<b>0,0</b>	<b>-7036,1</b>

#### Belastingen mastsectie dwarsrichting (y-richting) per windrichting

Omschrijving	P <sub>w</sub> [kN/m <sup>2</sup> ]	F <sub>y1</sub> [kN]	F <sub>y2</sub> [kN]	F <sub>y3</sub> [kN]	F <sub>y4</sub> [kN]	h <sub>ef</sub> [m]	M <sub>x1</sub> [kNm]	M <sub>x2</sub> [kNm]	M <sub>x3</sub> [kNm]	M <sub>x4</sub> [kNm]
Broekstuk	0,70	0,0	66,4	78,2	66,4	9,2	0,0	610,6	719,6	610,6
Eerste tussenstuk	0,90	0,0	24,0	28,2	24,0	21,8	0,0	522,3	615,6	522,3
Tweede tussenstuk	0,97	0,0	20,5	24,2	20,5	28,4	0,0	582,3	686,2	582,3
Bovenstuk 1	1,05	0,0	26,6	31,4	26,6	36,3	0,0	964,5	1136,7	964,5
Bovenstuk 2	1,12	0,0	30,3	35,7	30,3	47,7	0,0	1444,0	1701,8	1444,0
Topstuk	1,17	0,0	1,0	1,2	1,0	55,3	0,0	55,3	65,2	55,3
Ondertraverse	1,01	0,0	13,3	9,0	13,3	32,5	0,0	432,7	291,4	432,7
Middentraverse	1,08	0,0	20,4	13,8	20,4	42,1	0,0	859,2	578,6	859,2
Boventraverse	1,15	0,0	29,7	20,0	29,7	52,7	0,0	1565,3	1054,1	1565,3
<b>Totaal</b>		<b>0,0</b>	<b>232,2</b>	<b>241,6</b>	<b>232,2</b>		<b>0,0</b>	<b>7036,1</b>	<b>6849,1</b>	<b>7036,1</b>

#### Resulterende belastingen vanuit mastconstructie incl. antenne zonder geleiders niveau fundatie (kar. waarde)

Belasting / windrichting	F <sub>x</sub> [kN]	F <sub>y</sub> [kN]	F <sub>z</sub> [kN]	M <sub>x</sub> [kNm]	M <sub>y</sub> [kNm]	M <sub>z</sub> [kNm]
Permanente belasting	0	0	1050	0	0	0
Windrichting 0°	313	0	0	0	10015	0
Windrichting 45°	237	237	0	7234	7234	0
Windrichting 90°	0	249	0	7129	0	0
Windrichting 135°	-237	237	0	7234	-7234	0

Project: RLL-TLB380  
 Tower: HA+3\_c  
 Number: 1094

### Tussenresultaten geleiderbelastingen

#### Geleiders back

Circuit	Geleider	Diameter [mm]	A [mm <sup>2</sup> ]	G [N/m]	E [N/mm <sup>2</sup> ]	$\alpha T$ [-]
Circuit 1	AAAC-AL7 620	32,4	621,0	17,71	56000	2,30E-05
Circuit 2	AAAC-AL7 620	32,4	621,0	17,71	56000	2,30E-05
Circuit 3	AAAC-AL7 620	32,4	621,0	17,71	56000	2,30E-05
Circuit 4	AAAC-AL7 620	32,4	621,0	17,71	56000	2,30E-05
Bliksemdraad 1	AACSR 241-AL3-39-A20SA	21,8	281,0	9,38	70165	1,97E-05
Bliksemdraad 2	OPGW AFL-226/38	21,7	264,0	9,13	72000	1,98E-05

#### Geleiders ahead

Circuit	Geleider	Diameter [mm]	A [mm <sup>2</sup> ]	G [N/m]	E [N/mm <sup>2</sup> ]	$\alpha T$ [-]
Circuit 1	AAAC-AL7 620	32,4	621,0	17,71	56000	2,30E-05
Circuit 2	AAAC-AL7 620	32,4	621,0	17,71	56000	2,30E-05
Circuit 3	AAAC-AL7 620	32,4	621,0	17,71	56000	2,30E-05
Circuit 4	AAAC-AL7 620	32,4	621,0	17,71	56000	2,30E-05
Bliksemdraad 1	AACSR 241-AL3-39-A20SA	21,8	281,0	9,38	70165	1,97E-05
Bliksemdraad 2	OPGW AFL-226/38	21,7	264,0	9,13	72000	1,98E-05

#### Verticale belasting back

Circuit	Bundel [-]	Toeslag [%]	$W_{z,G}$ [N/m]	IJsgebied	Formule	$W_{z,ijs}$ [N/m]	$W_{z,ijs,bundel}$ [N/m]
Circuit 1	4	3	73,0	B	4+0,2d	10,5	41,9
Circuit 2	4	3	73,0	B	4+0,2d	10,5	41,9
Circuit 3	2	3	36,5	B	4+0,2d	10,5	21,0
Circuit 4	2	3	36,5	B	4+0,2d	10,5	21,0
Bliksemdraad 1	1	2	9,6	A	15+0,4d	23,7	23,7
Bliksemdraad 2	1	2	9,3	A	15+0,4d	23,7	23,7

#### Verticale belasting ahead

Circuit	Bundel [-]	Toeslag [%]	$W_{z,G}$ [N/m]	IJsgebied	Formule	$W_{z,ijs}$ [N/m]	$W_{z,ijs,bundel}$ [N/m]
Circuit 1	4	3	73,0	B	4+0,2d	10,5	41,9
Circuit 2	4	3	73,0	B	4+0,2d	10,5	41,9
Circuit 3	2	3	36,5	B	4+0,2d	10,5	21,0
Circuit 4	2	3	36,5	B	4+0,2d	10,5	21,0
Bliksemdraad 1	1	2	9,6	A	15+0,4d	23,7	23,7
Bliksemdraad 2	1	2	9,3	A	15+0,4d	23,7	23,7

#### Isolatoren

Geleider	$G_{isolator}$ [kN]	Aantal	$F_{v,iso}$ [kN]	Lengte [m]	Windopp. [m <sup>2</sup> ]	Windhoogte [m]	Stuwdruk [kN/m <sup>2</sup> ]	Vormfactor [-]	$F_{h,iso}$ [kN]
380ct1f1	3,00	1	3	6,5	2,2	51,50	1,14	1,2	3,02
380ct1f2	3,00	1	3	6,5	2,2	41,50	1,08	1,2	2,85
380ct1f3	3,00	1	3	6,5	2,2	32,00	1,01	1,2	2,66
380ct2f1	3,00	1	3	6,5	2,2	51,50	1,14	1,2	3,02
380ct2f2	3,00	1	3	6,5	2,2	41,50	1,08	1,2	2,85
380ct2f3	3,00	1	3	6,5	2,2	32,00	1,01	1,2	2,66
150ct3f1	2,00	1	2	4,5	1,0	51,50	1,14	1,2	1,37
150ct3f2	2,00	1	2	4,5	1,0	41,50	1,08	1,2	1,30
150ct3f3	2,00	1	2	4,5	1,0	32,00	1,01	1,2	1,21
150ct4f1	2,00	1	2	4,5	1,0	51,50	1,14	1,2	1,37
150ct4f2	2,00	1	2	4,5	1,0	41,50	1,08	1,2	1,30
150ct4f3	2,00	1	2	4,5	1,0	32,00	1,01	1,2	1,21
bl1	0,10	1	0,1	0,2	0,1	56,60	1,17	1,2	0,14
bl2	0,10	1	0,1	0,2	0,1	56,60	1,17	1,2	0,14

Project: RLL-TLB380  
 Tower: HA+3\_c  
 Number: 1094

#### Windbelasting back

Geleider	hoogte		$G_{c\_dwars}$	$G_{c\_trek}$	$C_c$	$d_{toeslag}$	$w_y$	$w_{y,vak}$	$D_{ijs,toeslag}$	$w_{y,ijs}$	$w_{y,ijs,vak}$
	wind	Stuwdruk									
	[m]	[kN/m <sup>2</sup> ]	[-]	[-]	[-]	[mm]	[N/m]	[N/m]	[mm]	[N/m]	[N/m]
380ct1f1	51,6	1,14	0,62	0,68	0,96	33,37	90,6	99,6	51,8	176,5	194,1
380ct1f2	41,6	1,08	0,60	0,66	0,98	33,37	85,0	93,5	51,8	162,2	178,5
380ct1f3	32,1	1,01	0,58	0,64	1,00	33,37	78,3	86,2	51,8	146,0	160,7
380ct2f1	51,6	1,14	0,62	0,68	0,96	33,37	90,6	99,6	51,8	176,5	194,1
380ct2f2	41,6	1,08	0,60	0,66	0,98	33,37	85,0	93,5	51,8	162,2	178,5
380ct2f3	32,1	1,01	0,58	0,64	1,00	33,37	78,3	86,2	51,8	146,0	160,7
150ct3f1	51,6	1,14	0,62	0,68	0,96	33,37	45,3	49,8	51,8	88,3	97,0
150ct3f2	41,6	1,08	0,60	0,66	0,98	33,37	42,5	46,7	51,8	81,1	89,2
150ct3f3	32,1	1,01	0,58	0,64	1,00	33,37	39,2	43,1	51,8	73,0	80,4
150ct4f1	51,6	1,14	0,62	0,68	0,96	33,37	45,3	49,8	51,8	88,3	97,0
150ct4f2	41,6	1,08	0,60	0,66	0,98	33,37	42,5	46,7	51,8	81,1	89,2
150ct4f3	32,1	1,01	0,58	0,64	1,00	33,37	39,2	43,1	51,8	73,0	80,4
bl1	56,7	1,17	0,63	0,69	1,18	22,24	19,3	21,2	63,1	55,7	61,2
bl2	56,7	1,17	0,63	0,69	1,18	22,13	19,2	21,1	63,0	55,6	61,2

#### Windbelasting ahead

Geleider	hoogte		$G_{c\_dwars}$	$G_{c\_trek}$	$C_c$	$d_{toeslag}$	$w_y$	$w_{y,vak}$	$D_{ijs,toeslag}$	$w_{y,ijs}$	$w_{y,ijs,vak}$
	wind	Stuwdruk									
	[m]	[kN/m <sup>2</sup> ]	[-]	[-]	[-]	[mm]	[N/m]	[N/m]	[mm]	[N/m]	[N/m]
380ct1f1	47,1	1,12	0,61	0,67	0,96	33,37	88,2	97,0	51,8	170,4	187,4
380ct1f2	37,1	1,05	0,59	0,65	0,99	33,37	82,0	90,3	51,8	155,0	170,5
380ct1f3	27,6	0,97	0,57	0,63	1,01	33,37	74,5	82,0	51,8	137,1	150,9
380ct2f1	47,1	1,12	0,61	0,67	0,96	33,37	88,2	97,0	51,8	170,4	187,4
380ct2f2	37,1	1,05	0,59	0,65	0,99	33,37	82,0	90,3	51,8	155,0	170,5
380ct2f3	27,6	0,97	0,57	0,63	1,01	33,37	74,5	82,0	51,8	137,1	150,9
150ct3f1	47,1	1,12	0,61	0,67	0,96	33,37	44,1	48,5	51,8	85,2	93,7
150ct3f2	37,1	1,05	0,59	0,65	0,99	33,37	41,0	45,1	51,8	77,5	85,3
150ct3f3	27,6	0,97	0,57	0,63	1,01	33,37	37,3	41,0	51,8	68,5	75,5
150ct4f1	47,1	1,12	0,61	0,67	0,96	33,37	44,1	48,5	51,8	85,2	93,7
150ct4f2	37,1	1,05	0,59	0,65	0,99	33,37	41,0	45,1	51,8	77,5	85,3
150ct4f3	27,6	0,97	0,57	0,63	1,01	33,37	37,3	41,0	51,8	68,5	75,5
bl1	52,2	1,15	0,62	0,68	1,18	22,24	18,7	20,6	63,1	54,0	59,4
bl2	52,2	1,15	0,62	0,68	1,18	22,13	18,7	20,5	63,0	53,9	59,3

NB: belastingen  $w_v$  gelden voor bundel

Project: RLL-TLB380  
 Masttype: HA+3\_c  
 Mast: 1094

Auteur: TBR  
 Versie: v12.0

**Geleiderbelastingen**

**Uitgangspunten**

Betrouwbaarheidsniveau Nieuwbouw CC2  
 Referentieperiode 50 jaar

<b>ULS</b> (bezwijksterkte)		<b>NEN-EN50341-2-15:2019</b>							
Belastingsgeval	omschrijving	Temp °C	$\gamma_G$		$\gamma_Q$			$\gamma_a$ $A_k$	
			$G_{k,mast}$	$G_{k,geleider}$	$Q_{pk}$	$Q_{wk}$	$Q_{ik}$		
ULS 1a	Wind	10°	1,20	1,20	0,00	1,50	0,00	0,0	
ULS 1a_0,9	Wind 0,9Gk alleen mast	10°	0,90	1,20	0,00	1,50	0,00	0,0	
ULS 1a_0,9_0,9	Wind 0,9Gk ook geleider	10°	0,90	0,90	0,00	1,50	0,00	0,0	
ULS 3	Wind+ijs	-5°	1,20	1,20	0,00	0,45	1,50	0,0	
ULS 3_0,9	Wind+ijs 0,9	-5°	0,90	1,20	0,00	0,45	1,50	0,0	
ULS 4	Koude+wind	-20°	1,20	1,20	0,00	0,30	0,00	0,0	
ULS 4_0,9	Koude+wind 0,9	-20°	0,90	1,20	0,00	0,30	0,00	0,0	
ULS 5a	Torsiebelastingen	10°	1,00	1,00	1,00	0,00	0,00	1,0	
ULS 5b	Longitudinale belastingen	10°	1,00	1,00	0,00	0,00	0,00	1,0	
ULS 6	Bouw en onderhoud	5°	1,20	1,20	1,50	0,30	0,00	0,0	
ULS 6_0,9	Bouw en onderhoud	5°	1,20	1,20	0,00	0,30	0,00	0,0	
ULS 7	Permanent	10°	1,35	1,35	0,00	0,00	0,00	0,0	
ULS 8	Special	10°	1,00	1,00	0,00	0,00	0,00	1,0	
<b>SPLS</b> (Bezwijksterkte, enkel voor hoekmasten: afwezigheid geleiders)				$\gamma_G$ $G_k$	$\gamma_Q$ $Q_{pk}$ $Q_{wk}$ $Q_{ik}$			$A_k$	
SPLS 1a	Wind	10°	1,20	1,20	0,0	0,78	0,00	0,0	
SPLS 1a_0,9	Wind 0,9	10°	0,90	1,20	0,0	0,78	0,00	0,0	
SPLS 1a_0,9_0,9	Wind 0,9	10°	0,90	0,90	0,0	0,78	0,00	0,0	
SPLS 3	Wind+ijs	-5°	1,20	1,20	0,0	0,36	0,34	0,0	
SPLS 3_0,9	Wind+ijs 0,9	-5°	0,90	1,20	0,0	0,36	0,34	0,0	
SPLS 4	Koude+wind	-20°	1,20	1,20	0,0	0,24	0,00	0,0	
SPLS 4_0,9	Koude+wind 0,9	-20°	0,90	1,20	0,0	0,24	0,00	0,0	
SPLS 6	Bouw en onderhoud	5°	1,20	1,20	1,2	0,24	0,0	0,0	
SPLS 6_0,9	Bouw en onderhoud	5°	1,20	1,20	0,0	0,24	0,0	0,0	
<b>SLS</b> (controle van de vervormingen, vermoeiing, EDS)				$G_k$	$Q_{pk}$	$Q_{wk}$	$Q_{ik}$	$A_k$	
SLS 1a	Wind	10°	1,00	1,00	0,0	1,00	0,0	0,0	
SLS 3	Wind+ijs	-5°	1,00	1,00	0,0	0,30	1,00	0,0	
SLS 4	Wind	-20°	1,00	1,00	0,0	0,20	0,0	0,0	
SLS 6	Bouw en onderhoud	5°	1,00	1,00	0,0	0,20	0,0	0,0	
SLS 7	PB (EDS, geen wind)	10°	1,00	1,00	0,0	0,00	0,0	0,0	

Aantal windrichtingen 6  
 Aantal belastingcombinaties ULS 100  
 Aantal belastingcombinaties SPLS 246  
 Aantal belastingcombinaties SLS 15  
 Aantal knooplasten 12274

Project: RLL-TLB380  
 Masttype: HA+3\_c  
 Mast: 1094

### Samenvattingstabellen geleiderbelastingen

In de onderstaande vier tabellen is weergegeven:

- De maximale geleiderbelasting in het globale assenstelsel, gesplitst in aandeel van back en ahead span
- De gecombineerde geleiderbelasting (Ba+Ah) in het globale assenstelsel met in het lokale assenstelsel de maximaal optredende trekkracht. Componenten Fx en Fy als absolute waarde
- De alledaagse (EDS) waarden van de gecombineerde geleiderbelastingen (Ba+Ah) met bijbehorende trekkrachten
- Controle op uplift, waar een negatieve waarde duidt op uplift

#### Maximale waarden voor back en ahead span

Geleider	Fx_ba [kN]	Fx_ah [kN]	Fy_ba [kN]	Fy_ah [kN]	Fz_ba [kN]	Fz_ah [kN]
bl1	-65,8	65,5	16,8	16,5	10,5	10,5
380ct1f1	-265,0	263,4	76,2	74,9	37,8	37,7
380ct1f2	-261,3	259,5	73,0	71,3	37,7	37,7
380ct1f3	-257,4	255,4	69,2	67,0	37,6	37,6
Post-isolato	0,0	0,0	0,0	0,0	0,0	
Post-isolato	0,0	0,0	0,0	0,0	0,0	
Post-isolato	0,0	0,0	0,0	0,0	0,0	
380ct2f1	-265,0	263,4	76,2	74,9	37,8	37,7
380ct2f2	-261,3	259,5	73,0	71,3	37,7	37,7
380ct2f3	-257,4	255,4	69,2	67,0	37,6	37,6
150ct3f1	-132,5	131,7	37,9	37,2	20,4	20,4
150ct3f2	-130,7	129,8	36,3	35,5	20,4	20,4
150ct3f3	-128,7	127,7	34,4	33,3	20,4	20,4
150ct4f1	-132,5	131,7	37,9	37,2	20,4	20,4
150ct4f2	-130,7	129,8	36,3	35,5	20,4	20,4
150ct4f3	-128,7	127,7	34,4	33,3	20,4	20,4
bl2	-64,9	64,5	16,6	16,4	10,5	10,5
Post-isolato	0,0	0,0	0,0	0,0	0,0	
Post-isolato	0,0	0,0	0,0	0,0	0,0	
Post-isolato	0,0	0,0	0,0	0,0	0,0	

#### Min. Weight span (m)

Weight spar Combinatie1

Geleider	SLS 1a	SLS 4	SLS 7
bl1	454,1	465,5	454,0
380ct1f1	454,0	464,3	454,0
380ct1f2	454,0	464,1	454,0
380ct1f3	454,0	463,9	454,0
Post-isolator 1			
Post-isolator 2			
Post-isolator 3			
380ct2f1	454,0	464,3	454,0
380ct2f2	454,0	464,1	454,0
380ct2f3	454,0	463,9	454,0
150ct3f1	454,0	464,3	454,0
150ct3f2	454,0	464,1	454,0
150ct3f3	454,0	463,9	454,0
150ct4f1	454,0	464,3	454,0
150ct4f2	454,0	464,1	454,0
150ct4f3	454,0	463,9	454,0
bl2	454,1	465,7	454,0
Post-isolator 4			
Post-isolator 5			
Post-isolator 6			

#### Max. Weight span (m)

Weight spar Combinatie1

Geleider	ULS 1a	ULS 3
bl1	517,7	442,8
380ct1f1	486,6	453,8
380ct1f2	483,5	453,0
380ct1f3	479,8	452,2
Post-isolator 1		
Post-isolator 2		
Post-isolator 3		
380ct2f1	486,6	453,8
380ct2f2	483,5	453,0
380ct2f3	479,8	452,2
150ct3f1	486,6	453,8
150ct3f2	483,5	453,0
150ct3f3	479,8	452,2
150ct4f1	486,6	453,8
150ct4f2	483,5	453,0
150ct4f3	479,8	452,2
bl2	519,4	442,6
Post-isolator 4		
Post-isolator 5		
Post-isolator 6		

Omhullende weight span over alle combinaties (incl. 0,9 combinaties)

Over alle geleiders	Wind / Weight span verhouding
Max. weight span	517,7 m 1,294 -
Min. weight span	130,0 m 0,325 -

Project: RLL-TLB380  
 Masttype: HA+3\_c  
 Mast: 1094

**Maximale waarden back+ahead span      Maximale waarden trekkracht geleider**

Geleider	Fx [kN]	Fy [kN]	Fz [kN]	Ft_ba [kN]	Ft_ah [kN]
bl1	39,0	32,9	10,5	-67,7	67,3
380ct1f1	206,2	147,7	37,8	-272,1	270,4
380ct1f2	202,4	141,1	37,7	-268,2	266,2
380ct1f3	198,3	133,3	37,6	-264,0	261,8
Post-isolato	4,3	4,3	6,8	0,0	
Post-isolato	3,3	3,3	4,7	0,0	
Post-isolato	4,9	4,9	6,8	0,0	
380ct2f1	206,2	147,7	37,8	-272,1	270,4
380ct2f2	202,4	141,1	37,7	-268,2	266,2
380ct2f3	198,3	133,3	37,6	-264,0	261,8
150ct3f1	108,3	73,5	20,4	-136,1	135,2
150ct3f2	108,2	70,2	20,4	-134,1	133,1
150ct3f3	108,1	66,3	20,4	-132,0	130,9
150ct4f1	108,3	73,5	20,4	-136,1	135,2
150ct4f2	108,2	70,2	20,4	-134,1	133,1
150ct4f3	108,1	66,3	20,4	-132,0	130,9
bl2	38,4	32,5	10,5	-66,8	66,4
Post-isolato	4,3	4,3	6,8	0,0	
Post-isolato	3,3	3,3	4,7	0,0	
Post-isolato	4,9	4,9	6,8	0,0	

**EDS-belastingen geleiders**

Geleider	Fx [kN]	Fy [kN]	Fz [kN]	Ft_ba [kN]	Ft_ah [kN]
bl1	17,0	3,0	2,3	-17,2	17,2
380ct1f1	129,3	22,8	19,6	-131,3	131,3
380ct1f2	129,3	22,8	19,6	-131,3	131,3
380ct1f3	129,3	22,8	19,6	-131,3	131,3
Post-isolato	0,0	0,0	5,0	0,0	
Post-isolato	0,0	0,0	3,5	0,0	
Post-isolato	0,0	0,0	5,0	0,0	
380ct2f1	129,3	22,8	19,6	-131,3	131,3
380ct2f2	129,3	22,8	19,6	-131,3	131,3
380ct2f3	129,3	22,8	19,6	-131,3	131,3
150ct3f1	64,7	11,4	10,3	-65,7	65,7
150ct3f2	64,7	11,4	10,3	-65,7	65,7
150ct3f3	64,7	11,4	10,3	-65,7	65,7
150ct4f1	64,7	11,4	10,3	-65,7	65,7
150ct4f2	64,7	11,4	10,3	-65,7	65,7
150ct4f3	64,7	11,4	10,3	-65,7	65,7
bl2	16,5	2,9	2,2	-16,8	16,8
Post-isolato	0,0	0,0	5,0	0,0	
Post-isolato	0,0	0,0	3,5	0,0	
Post-isolato	0,0	0,0	5,0	0,0	

**Controle uplift SLS-wind**

Combinatie: Geleider	Fz_ba [kN]	Fz_ah [kN]
SLS 4 bl1	0,0	0,0
380ct1f1	0,0	0,0
380ct1f2	0,0	0,0
380ct1f3	0,0	0,0
Post-isolato	0,0	
Post-isolato	0,0	
Post-isolato	0,0	
380ct2f1	0,0	0,0
380ct2f2	0,0	0,0
380ct2f3	0,0	0,0
150ct3f1	0,0	0,0
150ct3f2	0,0	0,0
150ct3f3	0,0	0,0
150ct4f1	0,0	0,0
150ct4f2	0,0	0,0
150ct4f3	0,0	0,0
bl2	0,0	0,0
Post-isolato	0,0	
Post-isolato	0,0	
Post-isolato	0,0	

Project: RLL-TLB380  
 Masttype: HA+3\_c  
 Mast: 1094

**ULS-fundatiebelasting combinatie 1 en 3 wind haaks op de lijn of bissectrice en EDS, vanuit geleiders**

Combinatie	Combination	$F_x$ [kN]	$F_y$ [kN]	$F_z$ [kN]	$M_x$ [kNm]	$M_y$ [kNm]	$M_z$ [kNm]
ULS 1a_90		-42	1343	497	56512	-1692	0
ULS 1a_0,9_0		28	490	347	20377	1164	0
ULS 1a_0,9_0,9_90		-46	1302	208	54834	-1857	0
ULS 3_0		9	806	754	33814	380	0
SLS 7		0	422	394	17560	0	0

**ULS-fundatiebelasting combinatie 1 en 3 wind haaks op de lijn of bissectrice en EDS, totaal geleiders en mast**

Combinatie	$F_x$ [kN]	$F_y$ [kN]	$F_z$ [kN]	$M_x$ [kNm]	$M_y$ [kNm]	$M_z$ [kNm]
ULS 1a_90	-42	1716	1757	67205	-1692	0
ULS 1a_0,9_0,9_90	-46	1675	1153	65527	-1857	0
SLS 7	0	422	1444	17560	0	0

**Fundatiebelastingen, selectie belastingcombinaties op basis grootste waarde**

Combinatie	$F_x$ [kN]	$F_y$ [kN]	$F_z$ [kN]	$M_x$ [kNm]	$M_y$ [kNm]	$M_z$ [kNm]
ULS 1a_0,9_90	-42	1716	1246	<b>67206</b>	-1692	0
SPLS 3_80 Ah All Cts	-1881	508	1582	20107	<b>-79016</b>	9
SPLS 3_80 Ba Ct1	904	685	1690	28630	37591	<b>-9731</b>
SPLS 3_0,9_80 Ah All Cts	-1881	508	1158	<b>20108</b>	<b>-79016</b>	9

*Noot: grootste waarden kunnen in meerdere combinaties voorkomen, een combinatie is weergegeven.*

**Oplegreacties op fundering per randstijl**

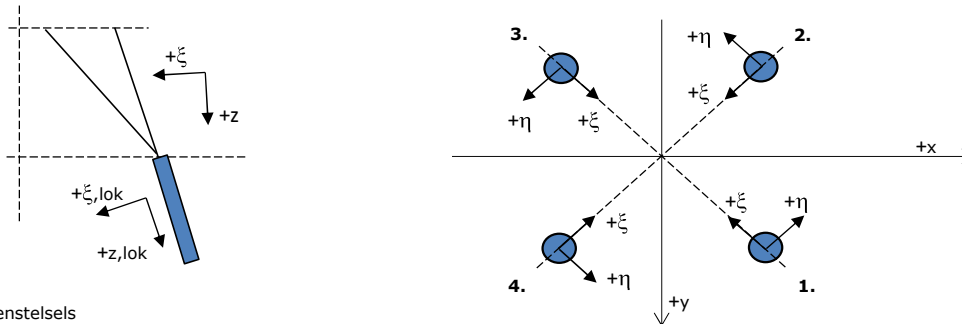

Assenstelsels

**Maximale drukbelasting**

Stijl	Combinatie	$R_x$ [kN]	$R_y$ [kN]	$R_z$ [kN]	$R_\eta$ [kN]	$R_\xi$ [kN]	$R_{\xi,lok}$ [kN]	$R_{z,lok}$ [kN]
1	SPLS 3_100 Ba All Cts	709	842	<b>4199</b>	-94	-1097	31	4348
2	ULS 8 Ah	422	-605	<b>2762</b>	129	-726	17	2860
3	ULS 8 Ba	-422	-605	<b>2762</b>	-129	-726	17	2860
4	SPLS 3_80 Ah All Cts	-716	850	<b>4237</b>	95	-1107	32	4387

**Maximale trekbelasting**

Stijl	Combinatie	$R_x$ [kN]	$R_y$ [kN]	$R_z$ [kN]	$R_\eta$ [kN]	$R_\xi$ [kN]	$R_{\xi,lok}$ [kN]	$R_{z,lok}$ [kN]
1	ULS 8 Ba	-263	-447	<b>-2007</b>	130	502	-37	-2078
2	SPLS 3_0,9_80 Ah All Cts	-573	706	<b>-3552</b>	-94	905	-50	-3678
3	SPLS 3_0,9_100 Ba All Cts	564	697	<b>-3503</b>	94	891	-50	-3627
4	SPLS 3_0,9_0 Ba All Cts	284	-456	<b>-2060</b>	-122	523	-30	-2133

**Maximale torsiebelasting (positief)**

Stijl	Combinatie	$R_x$ [kN]	$R_y$ [kN]	$R_z$ [kN]	$R_\eta$ [kN]	$R_\xi$ [kN]	$R_{\xi,lok}$ [kN]	$R_{z,lok}$ [kN]
1	SPLS 3_90 Ah Ct1	271	-246	5	<b>366</b>	-18	-17	5
2	SPLS 3_0,9_90 Ba Ct2	-111	-393	759	<b>357</b>	-200	4	786
3	SPLS 3_90 Ba Ct2	173	586	-2116	<b>292</b>	536	-32	-2191
4	SPLS 3_0,9_90 Ah Ct1	-350	747	2970	<b>280</b>	-776	22	3075

**Maximale torsiebelasting (negatief)**

Stijl	Combinatie	$R_x$ [kN]	$R_y$ [kN]	$R_z$ [kN]	$R_\eta$ [kN]	$R_\xi$ [kN]	$R_{\xi,lok}$ [kN]	$R_{z,lok}$ [kN]
1	SPLS 3_0,9_90 Ba Ct1	340	740	2921	<b>-283</b>	-764	20	3024
2	SPLS 3_90 Ah Ct2	-182	594	-2162	<b>-291</b>	548	-33	-2239
3	SPLS 3_0,9_90 Ah Ct2	103	-399	800	<b>-355</b>	-209	6	829
4	SPLS 3_90 Ba Ct1	-279	-240	43	<b>-367</b>	-28	-16	44

Project: RLL-TLB380  
 Masttype: HA+3\_c  
 Mast: 1094

#### Combinatie Ftrek+Fhor

Stijl	Combinatie	R <sub>x</sub> [kN]	R <sub>y</sub> [kN]	R <sub>z</sub> [kN]	R <sub>η</sub> [kN]	R <sub>ξ</sub> [kN]	R <sub>ξ,lok</sub> [kN]	R <sub>z,lok</sub> [kN]
1	SPLS 3_0,9_90 Ah All Cts	-249	-453	<b>-1999</b>	<b>144</b>	497	-40	-2070
2	SPLS 3_0,9_80 Ah All Cts	-573	706	<b>-3552</b>	<b>-94</b>	905	-50	-3678
3	SPLS 3_0,9_100 Ba All Cts	564	697	<b>-3503</b>	<b>94</b>	891	-50	-3627
4	SPLS 3_0,9_0 Ba All Cts	284	-456	<b>-2060</b>	<b>-122</b>	523	-30	-2133

#### Permanente belasting

Stijl	Combinatie	R <sub>x</sub> [kN]	R <sub>y</sub> [kN]	R <sub>z</sub> [kN]	R <sub>η</sub> [kN]	R <sub>ξ</sub> [kN]	R <sub>ξ,lok</sub> [kN]	R <sub>z,lok</sub> [kN]
1	SLS 7	218	181	1041	26	-282	-2	1078
2	SLS 7	-67	30	-320	26	69	-17	-331
3	SLS 7	67	30	-320	-26	69	-17	-331
4	SLS 7	-218	181	1041	-26	-282	-2	1078

#### Omhullenden ongeacht stijl

Belasting	Combinatie	R <sub>x</sub> [kN]	R <sub>y</sub> [kN]	R <sub>z</sub> [kN]	R <sub>η</sub> [kN]	R <sub>ξ</sub> [kN]	R <sub>ξ,lok</sub> [kN]	R <sub>z,lok</sub> [kN]
Max. druk	SPLS 3_80 Ah All Cts	-716	850	<b>4237</b>	95	-1107	32	4387
Max. trek	SPLS 3_0,9_80 Ah All Cts	-573	706	<b>-3552</b>	-94	905	-50	-3678
Max. pos. torsie	SPLS 3_90 Ah Ct1	271	-246	5	<b>366</b>	-18	-17	5
Max. neg. torsie	SPLS 3_90 Ba Ct1	-279	-240	43	<b>-367</b>	-28	-16	44
Comb. trek+torsie	SPLS 3_0,9_80 Ah All Cts	-573	706	<b>-3552</b>	<b>-94</b>	905	-50	-3678

#### Maximale trekbelasting SLS

Stijl	Combinatie	R <sub>x</sub> [kN]	R <sub>y</sub> [kN]	R <sub>z</sub> [kN]	R <sub>η</sub> [kN]	R <sub>ξ</sub> [kN]	R <sub>ξ,lok</sub> [kN]	R <sub>z,lok</sub> [kN]
1	SPLS 3_0,9_80 Ah All Cts	-247	-453	<b>-1994</b>	146	495	-41	-2064
2	SPLS 3_0,9_80 Ah All Cts	-573	706	<b>-3552</b>	-94	905	-50	-3678
3	SPLS 1a_0,9_100 Ba Ct2	249	597	<b>-2336</b>	246	599	-29	-2419
4	SPLS 3_0,9_100 Ba Ct2	131	102	<b>-161</b>	165	21	-23	-167

#### Maximale drukbelasting SLS

Stijl	Combinatie	R <sub>x</sub> [kN]	R <sub>y</sub> [kN]	R <sub>z</sub> [kN]	R <sub>η</sub> [kN]	R <sub>ξ</sub> [kN]	R <sub>ξ,lok</sub> [kN]	R <sub>z,lok</sub> [kN]
1	SPLS 1a_100 Ba Ct2	719	424	<b>3037</b>	209	-808	8	3145
2	SPLS 3_100 Ba Ct2	-77	-419	<b>919</b>	351	-242	5	951
3	SPLS 3_80 Ah All Cts	-390	-595	<b>2679</b>	-145	-697	23	2774
4	SPLS 3_80 Ah All Cts	-716	850	<b>4237</b>	95	-1107	32	4387



Project: RLL-TLB380  
Masttype: HA+3\_c  
Mast: 1094

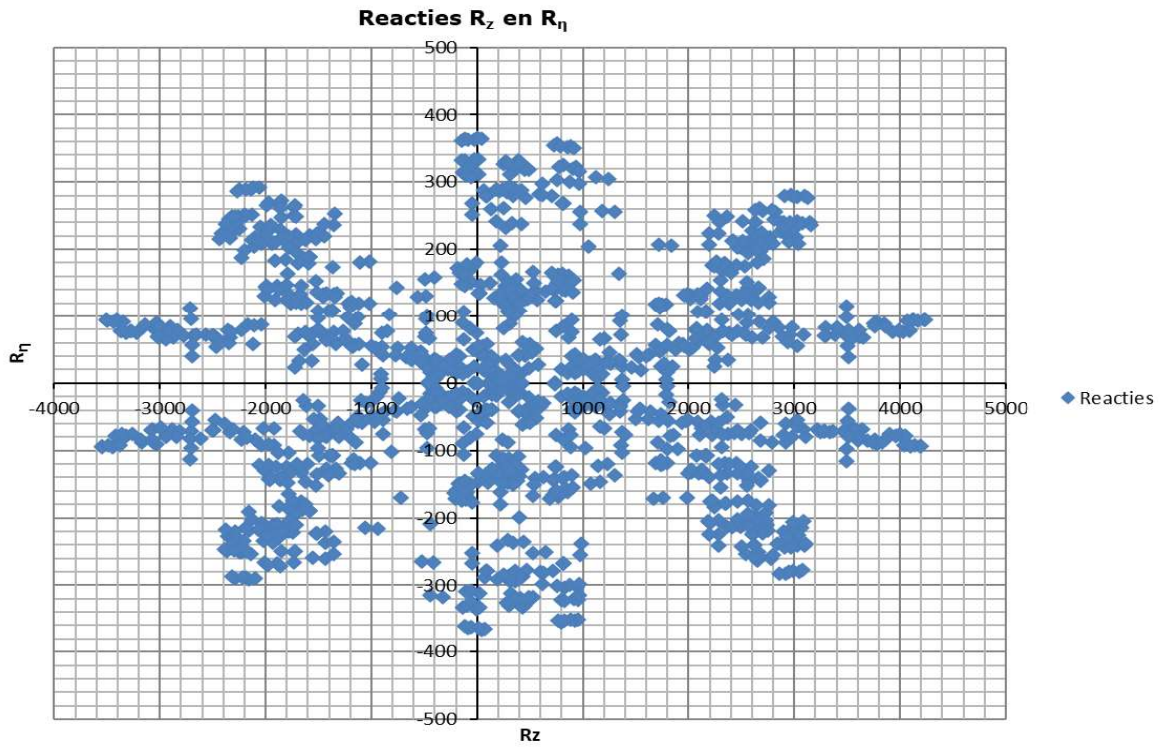



Project: RLL-TLB380  
Tower: HA+6\_c  
Number: 1078

Auteur: TBR  
Versie: v12.0

### Geleiderbelastingen

#### Algemeen

Benaming HA+6\_c  
Masttype Hoekmast  
Aantal circuits 4  
Configuratie 4-circuit-dubbel verticaal  
Aantal bliksemgeleiders 2

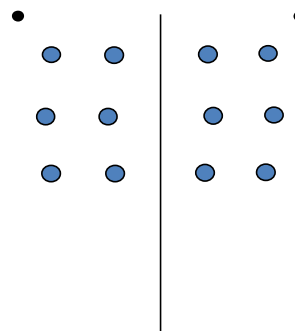

Configuratie geleiders

#### Uitgangspunten

Norm NEN-EN50341-2-15:2019  
Gevolgklasse initieel CC2  
Betrouwbaarheidsniveau initieel Nieuwbouw  
Referentieperiode initieel 50 jaar  
Betrouwbaarheidsniveau na aanpassing n.v.t.  
50 jaar  
Windgebied III  
Windsnelheid (m/s) 24,5 m/s  
Terreincategorie II  
Reductiefactor  $C_{dir}$  1,00  
IJSgebied fasegeleider B  
IJSgebied bliksemgeleider A

#### Geleiders Back

Omschrijving	Spanning	Geleider Back	Bundel Ba	IJSgebied	Toeslag gewicht	Toeslag diameter	Intrekwaarden $P_{back}$
Circuit 1	380 kV	AAAC-AL7 620	4	B	3 %	3 %	1800
Circuit 2	380 kV	AAAC-AL7 620	4	B	3 %	3 %	1800
Circuit 3	150 kV	AAAC-AL7 620	2	B	3 %	3 %	1800
Circuit 4	150 kV	AAAC-AL7 620	2	B	3 %	3 %	1800
Bliksemdraad 1		AACSR 241-AL3-39-A20SA	1	A	2 %	2 %	1800
Bliksemdraad 2		OPGW AFL-226/38	1	A	2 %	2 %	1800

#### Geleiders Ahead

Omschrijving	Spanning	Geleider Ahead	Bundel Ah	IJSgebied	Toeslag gewicht	Toeslag diameter	Intrekwaarden $P_{ahead}$
Circuit 1	380 kV	AAAC-AL7 620	4	B	3 %	3 %	1800
Circuit 2	380 kV	AAAC-AL7 620	4	B	3 %	3 %	1800
Circuit 3	150 kV	AAAC-AL7 620	2	B	3 %	3 %	1800
Circuit 4	150 kV	AAAC-AL7 620	2	B	3 %	3 %	1800
Bliksemdraad 1		AACSR 241-AL3-39-A20SA	1	A	2 %	2 %	1800
Bliksemdraad 2		OPGW AFL-226/38	1	A	2 %	2 %	1800

#### Isolatoren (1)

Omschrijving	Ophanging	Gewicht [kN]	Lengte [m]	Windopp. [m <sup>2</sup> ]
Circuit 1	Afspanketting	3,00	6,50	1,10
Circuit 2	Afspanketting	3,00	6,50	1,10
Circuit 3	Afspanketting	2,00	3,50	0,80
Circuit 4	Afspanketting	2,00	3,50	0,80
Bliksemdraad 1	Afspanketting	0,10	0,20	0,10
Bliksemdraad 2	Afspanketting	0,10	0,20	0,10

1. Eigenschappen gelden voor geheel van de isolatorset

#### Ophanghoogte en positie in mast

Circuits	Aanduiding	Nummer	Ophanghoogte	Aangrijppunt	Positie in mast Horizontale afstand
Circuit 1	10	380ct1f1	54,0 m	54,0 m	-10,8 m
Circuit 1	11	380ct1f2	44,0 m	44,0 m	-14,3 m
Circuit 1	12	380ct1f3	34,5 m	34,5 m	-11,4 m
Circuit 2	40	380ct2f1	54,0 m	54,0 m	10,8 m
Circuit 2	41	380ct2f2	44,0 m	44,0 m	14,3 m
Circuit 2	42	380ct2f3	34,5 m	34,5 m	11,4 m
Circuit 3	20	150ct3f1	54,0 m	54,0 m	-4,3 m
Circuit 3	21	150ct3f2	44,0 m	44,0 m	-7,8 m
Circuit 3	22	150ct3f3	34,5 m	34,5 m	-4,9 m
Circuit 4	30	150ct4f1	54,0 m	54,0 m	4,3 m
Circuit 4	31	150ct4f2	44,0 m	44,0 m	7,8 m
Circuit 4	32	150ct4f3	34,5 m	34,5 m	4,9 m
Bliksemdraad 1	1	bl1	59,1 m	59,1 m	-16,2 m
Bliksemdraad 2	3	bl2	59,1 m	59,1 m	16,2 m

Project: RLL-TLB380  
 Tower: HA+6\_c  
 Number: 1078

**Hoogteaanpassing naastgelegen masten** (aanpassing wind- en weight span)

	Back	Ahead	
Verhoging voor windbelasting	12,0 m	6,0 m	(positief: omhoog)
Verlaging voor verticale belasting	-9,0 m	-6,0 m	(negatief: omlaag, grotere weight span)
Verlaging:	Niet in 0,9EG-combinaties		

**Hoogteafwijking mastbeeld naastgelegen masten en richtingsverandering t.o.v. Lijnrichting**

Circuits	Aanduiding	Nummer	Hoogteverschil		Richtingsverandering	
			$\Delta h$ back	$\Delta h$ ahead	$\Delta y$ back	$\Delta y$ ahead
Circuit 1	10	380ct1f1	0,0	0,0 m	0,0	0,0 m
Circuit 1	11	380ct1f2	0,0	0,0 m	0,0	0,0 m
Circuit 1	12	380ct1f3	0,0	0,0 m	0,0	0,0 m
Circuit 2	40	380ct2f1	0,0	0,0 m	0,0	0,0 m
Circuit 2	41	380ct2f2	0,0	0,0 m	0,0	0,0 m
Circuit 2	42	380ct2f3	0,0	0,0 m	0,0	0,0 m
Circuit 3	20	150ct3f1	0,0	0,0 m	0,0	0,0 m
Circuit 3	21	150ct3f2	0,0	0,0 m	0,0	0,0 m
Circuit 3	22	150ct3f3	0,0	0,0 m	0,0	0,0 m
Circuit 4	30	150ct4f1	0,0	0,0 m	0,0	0,0 m
Circuit 4	31	150ct4f2	0,0	0,0 m	0,0	0,0 m
Circuit 4	32	150ct4f3	0,0	0,0 m	0,0	0,0 m
Bliksemdraad 1	1	bl1	0,0	0,0 m	0,0	0,0 m
Bliksemdraad 2	3	bl2	0,0	0,0 m	0,0	0,0 m

**Lijn- en mastgegevens**

	Back	Ahead
Ruling span $\sqrt{(\Sigma L^3)/\Sigma L}$	400,0	400,0 m
Lijnhoek $\beta$	160 °	
Rotatie mast t.o.v. bissectrice $\theta$	0 °	
Vaklengte	400	400 m
Hoogte onderkant mast t.o.v. maaiveld	0,5 m	
Beschouwde windrichtingen	$\alpha_1$	0 °
Windrichtingen volgens:	$\alpha_2$	45 °
Geleiderbelastingen	$\alpha_3$	90 °
	$\alpha_4$	135 °
	$\alpha_5$	80 °
	$\alpha_6$	100 °

Windrichtingen gelden t.o.v. hoofdrichting mastconstructie, niet t.o.v. bissectrice.

Windrichtingen en positieve richtingen belastingen

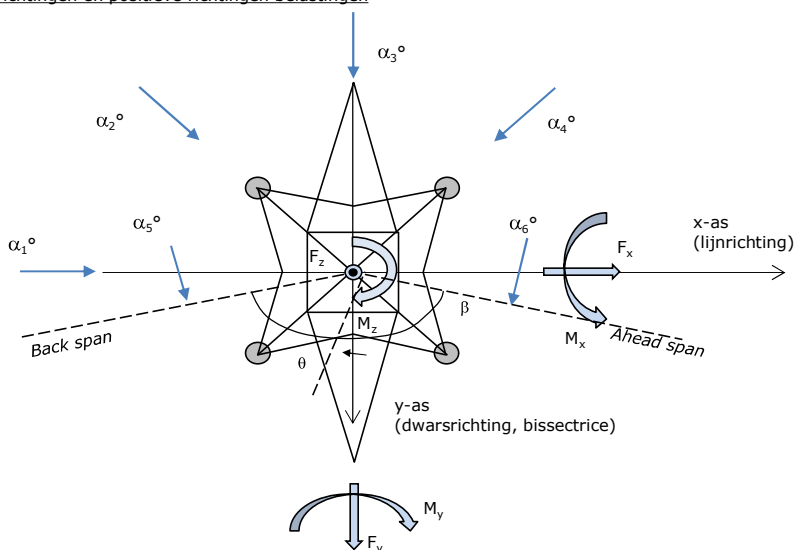

**Beschouwd aantal windrichtingen**

1a	6
3	6
4	1
6	1
Overig	1

Project: RLL-TLB380  
 Tower: HA+6\_c  
 Number: 1078

### Geleiderafval

		SPLS - torsie		SPLS - Enkelzijdige trek		5a - geleiderbreuk	
		Aanw.	Afw.	Aanw.	Afw.	Aanw.	Afw.
Circuit 1	380ct1f1	1	0	1	0	1	0
Circuit 1	380ct1f2	1	0	1	0	1	0
Circuit 1	380ct1f3	1	0	1	0	1	0
Circuit 2	380ct2f1	0	1	1	0	1	0
Circuit 2	380ct2f2	0	1	1	0	1	0
Circuit 2	380ct2f3	0	1	1	0	1	0
Circuit 3	150ct3f1	1	0	1	0	1	0
Circuit 3	150ct3f2	1	0	1	0	1	0
Circuit 3	150ct3f3	1	0	1	0	1	0
Circuit 4	150ct4f1	0	1	1	0	1	0
Circuit 4	150ct4f2	0	1	1	0	1	0
Circuit 4	150ct4f3	0	1	1	0	1	0
Bliksemdraad 1	b11	1	0	1	0	1	0
Bliksemdraad 2	b12	0	1	1	0	1	0

### Belastingssituaties SPLS

Beschouwde situaties SPLS: 1 t/m 6, alle mogelijke situaties.

Principe belastingssituaties:

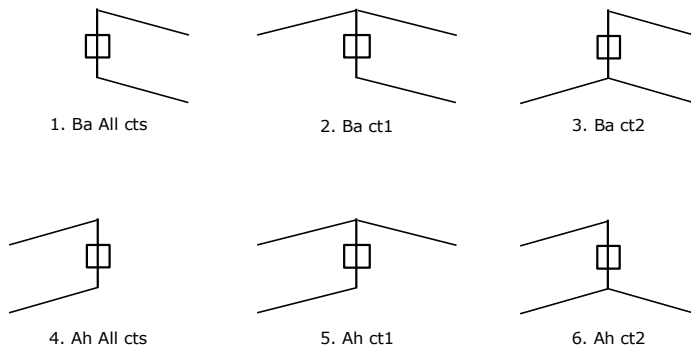

### Belastingssituaties 5a. Geleiderbreuk

Beschouwde situaties geleiderbreuk 5a: 1 en 2, alle mogelijke situaties.

Principe belastingssituaties:

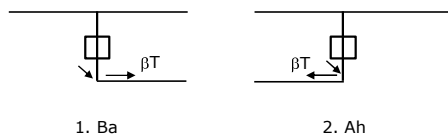

Project: RLL-TLB380  
 Tower: HA+6\_c  
 Number: 1078

### Belastingsituaties 6. Bouw- en onderhoud

Onder 6a wordt de belasting door aanwezigheid lijnwagen of lijnfiets in combinatie met puntlast op traverse in rekening gebracht. Combinatie 6b bevat geen belastingen in geleider of op traverse. Deze combinatie is toegevoegd om te kunnen combineren met separate controle bordessen etc. De situaties worden in ULS en in iedere SPLS-situatie (in geval van hoekmast) toegepast.

	Fase	Bliksem
Lijnwagen	4,0 kN	2,0 kN
Puntlast op traverse	1,0 kN	1,0 kN

Beschouwde situaties bouw- en onderhoud 6a: 1 t/m 4, alle mogelijke situaties.

Aanwezigheid lijnwagen: Circuit, belasting tegelijk aanwezig in alle geleiders per circuit.

Principe belastingssituaties:

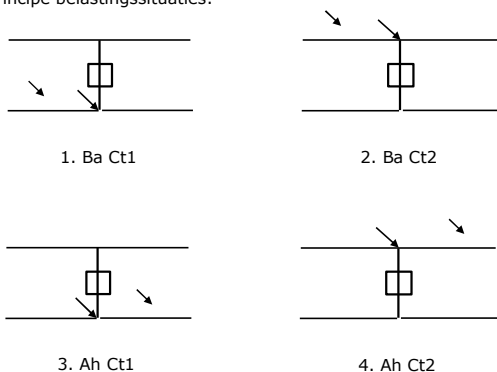

### Belastingsituaties 8. Lijndansen als statische belasting

Geleider		
Steunmast fase	0,866 W	1,5 W
Steunmast bliksem	1,5 EDS	1,5 W
Hoekmast fase en bliksem	1,5 EDS	1,5 W

Beschouwde situaties lijndansen 8: 1 en 2, alle mogelijke situaties.

Belasting tegelijk aanwezig in alle geleiders van het circuit.

Principe belastingssituaties:

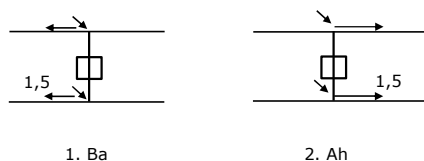

### Belastingcombinatie 8. Lijndansen als dynamische belasting

Alleen van toepassing op hoek- en eindmasten

Belasting bestaat uit EDS-trekbelasting in één van de geleiders aan één zijde van de mast

Door gebruiker via het belastingsspectrum van tabel 4.11/NL.1 om te zetten naar spanningspectrum

Project: RLL-TLB380  
 Tower: HA+6\_c  
 Number: 1078

## Mastconstructie

### Eigenschappen

Masttype	Hoekmast	
Mastbenaming	HA+6_c	
Voetplaat t.o.v. maaiveld	0,5 m	
Masthoogte t.o.v. voetplaat	59,1 m	
Gewicht mast	1124,0 kN	
<i>Breedte en helling mast bij fundatie</i>	x-ri.	y-ri.
Pootsprei	14,04	14,04 m
Helling van de randstijl	0,190	0,190 -
Factor spatkracht	1,1	1,1 -

### Berekening windbelasting

Dynamische invloed $G_T$	1,00 (Masthoogte < 60 m)
Windbelasting overhoeks op mastlichaam evenredig met:	$(A1C1\sin^2(\phi)+A2C2\cos^2(\phi))$
Windbelasting overhoeks op traverse evenredig met:	$(A1C1\sin^2(\phi)+A2C2\cos^2(\phi))$
Vergroting wind overhoeks mastlichaam	$(1+0,2\sin^2(2\phi))$
Vergroting wind overhoeks traverse	$(1+0,2\sin^2(2\phi))$
Factor wind evenwijdig t.o.v. haaks op traverse	0,4

### Eigenschappen mastsecties langsrichting (vooraanzicht, yz-vlak)

Omschrijving	h [m]	b <sub>1</sub> [m]	b <sub>2</sub> [m]	Δh [m]	Δ <sub>x</sub> [m]	A <sub>0</sub> [m <sup>2</sup> ]	A <sub>1</sub> [m <sup>2</sup> ]	χ = A <sub>1</sub> /A <sub>0</sub> [-]	C <sub>t</sub>
Broekstuk	21,40	14,04	5,91	21,40	0,190	213,49	48,90	0,23	2,81
Eerste tussenstuk	28,20	5,91	5,23	6,80	0,050	37,88	13,24	0,35	2,37
Tweede tussenstuk	34,50	5,23	4,60	6,30	0,050	30,96	10,25	0,33	2,43
Bovenstuk 1	44,00	4,60	3,65	9,50	0,050	39,19	11,88	0,30	2,52
Bovenstuk 2	57,40	3,65	2,31	13,40	0,050	39,93	13,01	0,33	2,45
Topstuk	59,10	2,31		1,70		1,96	0,33	0,17	3,08
Ondertraverse	34,50	9,40		3,10		14,57	4,37	0,30	2,54
Middentraverse	44,00	12,78		3,20		20,45	6,34	0,31	2,50
Boventraverse	54,00	14,88		5,10		37,93	7,34	0,19	2,96

### Eigenschappen mastsecties dwarsrichting (zijaanzicht, xz-vlak)

Omschrijving	h [m]	b <sub>1</sub> [m]	b <sub>2</sub> [m]	Δh [m]	Δ <sub>x</sub> [m]	A <sub>0</sub> [m <sup>2</sup> ]	A <sub>1</sub> [m <sup>2</sup> ]	χ = A <sub>1</sub> /A <sub>0</sub> [-]	C <sub>t</sub>
Broekstuk	21,40	14,04	5,91	21,40	0,190	213,49	48,90	0,23	2,81
Eerste tussenstuk	28,20	5,91	5,23	6,80	0,050	37,88	13,24	0,35	2,37
Tweede tussenstuk	34,50	5,23	4,60	6,30	0,050	30,96	10,25	0,33	2,43
Bovenstuk 1	44,00	4,60	3,65	9,50	0,050	39,19	11,88	0,30	2,52
Bovenstuk 2	57,40	3,65	2,31	13,40	0,050	39,93	13,01	0,33	2,45
Topstuk	59,10	2,31		1,70		1,96	0,33	0,17	3,08
Ondertraverse	34,50	9,40		3,10		14,57	4,37	0,30	2,54
Middentraverse	44,00	12,78		3,20		20,45	6,34	0,31	2,50
Boventraverse	54,00	14,88		5,10		37,93	7,34	0,19	2,96

NB: oppervlakte traverse dwarsrichting van de tabel wordt in berekening gereduceerd.  
 NB: oppervlakte traverse per zijde, dus helft van totaal van twee traveses.

Project: RLL-TLB380  
 Tower: HA+6\_c  
 Number: 1078

#### Windoppervlak feeders telecominstallaties

Onderdeel	A (m <sup>2</sup> /m)	Factor	Δh	A <sub>1</sub>
Broekstuk	0,14	0,71	21,4	2,1
Eerste tussenstuk	0,14	0,71	6,8	0,7
Tweede tussenstuk	0,14	0,71	6,3	0,6
Bovenstuk 1	0,14	0,71	9,5	0,9
Bovenstuk 2				

#### Invoer antennes

Omschrijving	A (m <sup>2</sup> )	h (m)	C <sub>i</sub> (m)
Antenne top			
Antenne o.t.	4,7	40,7	1,5

#### Belastingen mastsectie langsrichting (x-richting) per windrichting

Omschrijving	P <sub>w</sub> [kN/m <sup>2</sup> ]	F <sub>x1</sub> [kN]	F <sub>x2</sub> [kN]	F <sub>x3</sub> [kN]	F <sub>x4</sub> [kN]	h <sub>ef</sub> [m]	M <sub>y1</sub> [kNm]	M <sub>y2</sub> [kNm]	M <sub>y3</sub> [kNm]	M <sub>y4</sub> [kNm]
Broekstuk	0,72	98,5	83,6	0,0	-83,6	10,7	1054,1	894,4	0,0	-894,4
Eerste tussenstuk	0,94	29,3	24,9	0,0	-24,9	24,8	727,4	617,3	0,0	-617,3
Tweede tussenstuk	1,00	24,9	21,1	0,0	-21,1	31,4	780,8	662,5	0,0	-662,5
Bovenstuk 1	1,07	32,0	27,2	0,0	-27,2	39,3	1257,3	1066,9	0,0	-1066,9
Bovenstuk 2	1,14	36,3	30,8	0,0	-30,8	50,7	1837,9	1559,5	0,0	-1559,5
Topstuk	1,18	1,2	1,0	0,0	-1,0	58,3	69,6	59,1	0,0	-59,1
Ondertraverse	1,04	22,9	13,6	0,0	-13,6	35,5	815,3	484,2	0,0	-484,2
Middentraverse	1,10	35,0	20,8	0,0	-20,8	45,1	1578,4	937,5	0,0	-937,5
Boventraverse	1,17	50,7	30,1	0,0	-30,1	55,7	2825,4	1678,2	0,0	-1678,2
<b>Totaal</b>		<b>330,9</b>	<b>253,1</b>	<b>0,0</b>	<b>-253,1</b>		<b>10946,2</b>	<b>7959,6</b>	<b>0,0</b>	<b>-7959,6</b>

#### Belastingen mastsectie dwarsrichting (y-richting) per windrichting

Omschrijving	P <sub>w</sub> [kN/m <sup>2</sup> ]	F <sub>y1</sub> [kN]	F <sub>y2</sub> [kN]	F <sub>y3</sub> [kN]	F <sub>y4</sub> [kN]	h <sub>ef</sub> [m]	M <sub>x1</sub> [kNm]	M <sub>x2</sub> [kNm]	M <sub>x3</sub> [kNm]	M <sub>x4</sub> [kNm]
Broekstuk	0,72	0,0	83,6	98,5	83,6	10,7	0,0	894,4	1054,1	894,4
Eerste tussenstuk	0,94	0,0	24,9	29,3	24,9	24,8	0,0	617,3	727,4	617,3
Tweede tussenstuk	1,00	0,0	21,1	24,9	21,1	31,4	0,0	662,5	780,8	662,5
Bovenstuk 1	1,07	0,0	27,2	32,0	27,2	39,3	0,0	1066,9	1257,3	1066,9
Bovenstuk 2	1,14	0,0	30,8	36,3	30,8	50,7	0,0	1559,5	1837,9	1559,5
Topstuk	1,18	0,0	1,0	1,2	1,0	58,3	0,0	59,1	69,6	59,1
Ondertraverse	1,04	0,0	13,6	9,2	13,6	35,5	0,0	484,2	326,1	484,2
Middentraverse	1,10	0,0	20,8	14,0	20,8	45,1	0,0	937,5	631,3	937,5
Boventraverse	1,17	0,0	30,1	20,3	30,1	55,7	0,0	1678,2	1130,2	1678,2
<b>Totaal</b>		<b>0,0</b>	<b>253,1</b>	<b>265,7</b>	<b>253,1</b>		<b>0,0</b>	<b>7959,6</b>	<b>7814,8</b>	<b>7959,6</b>

#### Resulterende belastingen vanuit mastconstructie incl. antenne zonder geleiders niveau fundatie (kar. waarde)

Belasting / windrichting	F <sub>x</sub> [kN]	F <sub>y</sub> [kN]	F <sub>z</sub> [kN]	M <sub>x</sub> [kNm]	M <sub>y</sub> [kNm]	M <sub>z</sub> [kNm]
Permanente belasting	0	0	1124	0	0	0
Windrichting 0°	339	0	0	0	11255	0
Windrichting 45°	258	258	0	8178	8178	0
Windrichting 90°	0	273	0	8123	0	0
Windrichting 135°	-258	258	0	8178	-8178	0



Project: RLL-TLB380  
 Tower: HA+6\_c  
 Number: 1078

### Tussenresultaten geleiderbelastingen

#### Geleiders back

Circuit	Geleider	Diameter [mm]	A [mm <sup>2</sup> ]	G [N/m]	E [N/mm <sup>2</sup> ]	$\alpha T$ [-]
Circuit 1	AAAC-AL7 620	32,4	621,0	17,71	56000	2,30E-05
Circuit 2	AAAC-AL7 620	32,4	621,0	17,71	56000	2,30E-05
Circuit 3	AAAC-AL7 620	32,4	621,0	17,71	56000	2,30E-05
Circuit 4	AAAC-AL7 620	32,4	621,0	17,71	56000	2,30E-05
Bliksemdraad 1	AACSR 241-AL3-39-A20SA	21,8	281,0	9,38	70165	1,97E-05
Bliksemdraad 2	OPGW AFL-226/38	21,7	264,0	9,13	72000	1,98E-05

#### Geleiders ahead

Circuit	Geleider	Diameter [mm]	A [mm <sup>2</sup> ]	G [N/m]	E [N/mm <sup>2</sup> ]	$\alpha T$ [-]
Circuit 1	AAAC-AL7 620	32,4	621,0	17,71	56000	2,30E-05
Circuit 2	AAAC-AL7 620	32,4	621,0	17,71	56000	2,30E-05
Circuit 3	AAAC-AL7 620	32,4	621,0	17,71	56000	2,30E-05
Circuit 4	AAAC-AL7 620	32,4	621,0	17,71	56000	2,30E-05
Bliksemdraad 1	AACSR 241-AL3-39-A20SA	21,8	281,0	9,38	70165	1,97E-05
Bliksemdraad 2	OPGW AFL-226/38	21,7	264,0	9,13	72000	1,98E-05

#### Verticale belasting back

Circuit	Bundel [-]	Toeslag [%]	$W_{z,G}$ [N/m]	IJsgebied	Formule	$W_{z,ijs}$ [N/m]	$W_{z,ijs,bundel}$ [N/m]
Circuit 1	4	3	73,0	B	4+0,2d	10,5	41,9
Circuit 2	4	3	73,0	B	4+0,2d	10,5	41,9
Circuit 3	2	3	36,5	B	4+0,2d	10,5	21,0
Circuit 4	2	3	36,5	B	4+0,2d	10,5	21,0
Bliksemdraad 1	1	2	9,6	A	15+0,4d	23,7	23,7
Bliksemdraad 2	1	2	9,3	A	15+0,4d	23,7	23,7

#### Verticale belasting ahead

Circuit	Bundel [-]	Toeslag [%]	$W_{z,G}$ [N/m]	IJsgebied	Formule	$W_{z,ijs}$ [N/m]	$W_{z,ijs,bundel}$ [N/m]
Circuit 1	4	3	73,0	B	4+0,2d	10,5	41,9
Circuit 2	4	3	73,0	B	4+0,2d	10,5	41,9
Circuit 3	2	3	36,5	B	4+0,2d	10,5	21,0
Circuit 4	2	3	36,5	B	4+0,2d	10,5	21,0
Bliksemdraad 1	1	2	9,6	A	15+0,4d	23,7	23,7
Bliksemdraad 2	1	2	9,3	A	15+0,4d	23,7	23,7

#### Isolatoren

Geleider	$G_{isolator}$ [kN]	Aantal	$F_{v,iso}$ [kN]	Lengte [m]	Windopp. [m <sup>2</sup> ]	Windhoogte [m]	Stuwdruk [kN/m <sup>2</sup> ]	Vormfactor [-]	$F_{h,iso}$ [kN]
380ct1f1	3,00	1	3	6,5	1,1	54,50	1,16	1,2	1,53
380ct1f2	3,00	1	3	6,5	1,1	44,50	1,10	1,2	1,45
380ct1f3	3,00	1	3	6,5	1,1	35,00	1,03	1,2	1,36
380ct2f1	3,00	1	3	6,5	1,1	54,50	1,16	1,2	1,53
380ct2f2	3,00	1	3	6,5	1,1	44,50	1,10	1,2	1,45
380ct2f3	3,00	1	3	6,5	1,1	35,00	1,03	1,2	1,36
150ct3f1	2,00	1	2	3,5	0,8	54,50	1,16	1,2	1,11
150ct3f2	2,00	1	2	3,5	0,8	44,50	1,10	1,2	1,06
150ct3f3	2,00	1	2	3,5	0,8	35,00	1,03	1,2	0,99
150ct4f1	2,00	1	2	3,5	0,8	54,50	1,16	1,2	1,11
150ct4f2	2,00	1	2	3,5	0,8	44,50	1,10	1,2	1,06
150ct4f3	2,00	1	2	3,5	0,8	35,00	1,03	1,2	0,99
bl1	0,10	1	0,1	0,2	0,1	59,60	1,19	1,2	0,14
bl2	0,10	1	0,1	0,2	0,1	59,60	1,19	1,2	0,14

Project: RLL-TLB380  
 Tower: HA+6\_c  
 Number: 1078

#### Windbelasting back

Geleider	hoogte		$G_{c\_dwars}$	$G_{c\_trek}$	$C_c$	$d_{toeslag}$	$W_y$	$W_{y,vak}$	$D_{ijs,toeslag}$	$W_{y,ijs}$	$W_{y,ijs,vak}$
	wind	Stuwdruk									
	[m]	[kN/m <sup>2</sup> ]	[-]	[-]	[-]	[mm]	[N/m]	[N/m]	[mm]	[N/m]	[N/m]
380ct1f1	53,1	1,15	0,62	0,68	0,95	33,37	91,4	100,4	51,8	178,5	196,2
380ct1f2	43,1	1,09	0,61	0,67	0,97	33,37	85,9	94,5	51,8	164,5	181,0
380ct1f3	33,6	1,02	0,59	0,65	1,00	33,37	79,5	87,5	51,8	148,8	163,8
380ct2f1	53,1	1,15	0,62	0,68	0,95	33,37	91,4	100,4	51,8	178,5	196,2
380ct2f2	43,1	1,09	0,61	0,67	0,97	33,37	85,9	94,5	51,8	164,5	181,0
380ct2f3	33,6	1,02	0,59	0,65	1,00	33,37	79,5	87,5	51,8	148,8	163,8
150ct3f1	53,1	1,15	0,62	0,68	0,95	33,37	45,7	50,2	51,8	89,2	98,1
150ct3f2	43,1	1,09	0,61	0,67	0,97	33,37	42,9	47,2	51,8	82,3	90,5
150ct3f3	33,6	1,02	0,59	0,65	1,00	33,37	39,7	43,7	51,8	74,4	81,9
150ct4f1	53,1	1,15	0,62	0,68	0,95	33,37	45,7	50,2	51,8	89,2	98,1
150ct4f2	43,1	1,09	0,61	0,67	0,97	33,37	42,9	47,2	51,8	82,3	90,5
150ct4f3	33,6	1,02	0,59	0,65	1,00	33,37	39,7	43,7	51,8	74,4	81,9
bl1	58,2	1,18	0,63	0,69	1,18	22,24	19,4	21,3	63,1	56,3	61,8
bl2	58,2	1,18	0,63	0,69	1,18	22,13	19,4	21,3	63,0	56,2	61,8

#### Windbelasting ahead

Geleider	hoogte		$G_{c\_dwars}$	$G_{c\_trek}$	$C_c$	$d_{toeslag}$	$W_y$	$W_{y,vak}$	$D_{ijs,toeslag}$	$W_{y,ijs}$	$W_{y,ijs,vak}$
	wind	Stuwdruk									
	[m]	[kN/m <sup>2</sup> ]	[-]	[-]	[-]	[mm]	[N/m]	[N/m]	[mm]	[N/m]	[N/m]
380ct1f1	50,1	1,14	0,62	0,68	0,96	33,37	89,8	98,8	51,8	174,5	191,9
380ct1f2	40,1	1,07	0,60	0,66	0,98	33,37	84,0	92,4	51,8	159,9	175,9
380ct1f3	30,6	0,99	0,58	0,64	1,00	33,37	77,1	84,9	51,8	143,2	157,6
380ct2f1	50,1	1,14	0,62	0,68	0,96	33,37	89,8	98,8	51,8	174,5	191,9
380ct2f2	40,1	1,07	0,60	0,66	0,98	33,37	84,0	92,4	51,8	159,9	175,9
380ct2f3	30,6	0,99	0,58	0,64	1,00	33,37	77,1	84,9	51,8	143,2	157,6
150ct3f1	50,1	1,14	0,62	0,68	0,96	33,37	44,9	49,4	51,8	87,3	95,9
150ct3f2	40,1	1,07	0,60	0,66	0,98	33,37	42,0	46,2	51,8	79,9	88,0
150ct3f3	30,6	0,99	0,58	0,64	1,00	33,37	38,6	42,4	51,8	71,6	78,8
150ct4f1	50,1	1,14	0,62	0,68	0,96	33,37	44,9	49,4	51,8	87,3	95,9
150ct4f2	40,1	1,07	0,60	0,66	0,98	33,37	42,0	46,2	51,8	79,9	88,0
150ct4f3	30,6	0,99	0,58	0,64	1,00	33,37	38,6	42,4	51,8	71,6	78,8
bl1	55,2	1,17	0,62	0,69	1,18	22,24	19,1	21,0	63,1	55,2	60,6
bl2	55,2	1,17	0,62	0,69	1,18	22,13	19,0	20,9	63,0	55,1	60,5

NB: belastingen  $w_v$  gelden voor bundel

Project: RLL-TLB380  
 Masttype: HA+6\_c  
 Mast: 1078

Auteur: TBR  
 Versie: v12.0

**Geleiderbelastingen**

**Uitgangspunten**

Betrouwbaarheidsniveau Nieuwbouw CC2  
 Referentieperiode 50 jaar

<b>ULS</b> (bezwijksterkte)		<b>NEN-EN50341-2-15:2019</b>							
Belastingsgeval	omschrijving	Temp °C	$\gamma_G$		$\gamma_Q$			$\gamma_a$ $A_k$	
			$G_{k,mast}$	$G_{k,geleider}$	$Q_{pk}$	$Q_{wk}$	$Q_{ik}$		
ULS 1a	Wind	10°	1,20	1,20	0,00	1,50	0,00	0,0	
ULS 1a_0,9	Wind 0,9Gk alleen mast	10°	0,90	1,20	0,00	1,50	0,00	0,0	
ULS 1a_0,9_0,9	Wind 0,9Gk ook geleider	10°	0,90	0,90	0,00	1,50	0,00	0,0	
ULS 3	Wind+ijs	-5°	1,20	1,20	0,00	0,45	1,50	0,0	
ULS 3_0,9	Wind+ijs 0,9	-5°	0,90	1,20	0,00	0,45	1,50	0,0	
ULS 4	Koude+wind	-20°	1,20	1,20	0,00	0,30	0,00	0,0	
ULS 4_0,9	Koude+wind 0,9	-20°	0,90	1,20	0,00	0,30	0,00	0,0	
ULS 5a	Torsiebelastingen	10°	1,00	1,00	1,00	0,00	0,00	1,0	
ULS 5b	Longitudinale belastingen	10°	1,00	1,00	0,00	0,00	0,00	1,0	
ULS 6	Bouw en onderhoud	5°	1,20	1,20	1,50	0,30	0,00	0,0	
ULS 6_0,9	Bouw en onderhoud	5°	1,20	1,20	0,00	0,30	0,00	0,0	
ULS 7	Permanent	10°	1,35	1,35	0,00	0,00	0,00	0,0	
ULS 8	Special	10°	1,00	1,00	0,00	0,00	0,00	1,0	
<b>SPLS</b> (Bezwijksterkte, enkel voor hoekmasten: afwezigheid geleiders)			$\gamma_G$		$\gamma_Q$				
			$G_k$	$G_k$	$Q_{pk}$	$Q_{wk}$	$Q_{ik}$	$A_k$	
SPLS 1a	Wind	10°	1,20	1,20	0,0	0,78	0,00	0,0	
SPLS 1a_0,9	Wind 0,9	10°	0,90	1,20	0,0	0,78	0,00	0,0	
SPLS 1a_0,9_0,9	Wind 0,9	10°	0,90	0,90	0,0	0,78	0,00	0,0	
SPLS 3	Wind+ijs	-5°	1,20	1,20	0,0	0,36	0,34	0,0	
SPLS 3_0,9	Wind+ijs 0,9	-5°	0,90	1,20	0,0	0,36	0,34	0,0	
SPLS 4	Koude+wind	-20°	1,20	1,20	0,0	0,24	0,00	0,0	
SPLS 4_0,9	Koude+wind 0,9	-20°	0,90	1,20	0,0	0,24	0,00	0,0	
SPLS 6	Bouw en onderhoud	5°	1,20	1,20	1,2	0,24	0,0	0,0	
SPLS 6_0,9	Bouw en onderhoud	5°	1,20	1,20	0,0	0,24	0,0	0,0	
<b>SLS</b> (controle van de vervormingen, vermoeiing, EDS)			$G_k$		$Q_{pk}$	$Q_{wk}$	$Q_{ik}$	$A_k$	
			$G_k$	$G_k$	$Q_{pk}$	$Q_{wk}$	$Q_{ik}$	$A_k$	
SLS 1a	Wind	10°	1,00	1,00	0,0	1,00	0,0	0,0	
SLS 3	Wind+ijs	-5°	1,00	1,00	0,0	0,30	1,00	0,0	
SLS 4	Wind	-20°	1,00	1,00	0,0	0,20	0,0	0,0	
SLS 6	Bouw en onderhoud	5°	1,00	1,00	0,0	0,20	0,0	0,0	
SLS 7	PB (EDS, geen wind)	10°	1,00	1,00	0,0	0,00	0,0	0,0	

Aantal windrichtingen 6  
 Aantal belastingcombinaties ULS 100  
 Aantal belastingcombinaties SPLS 246  
 Aantal belastingcombinaties SLS 15  
 Aantal knooplasten 12274

Project: RLL-TLB380  
 Masttype: HA+6\_c  
 Mast: 1078

### Samenvattingstabellen geleiderbelastingen

In de onderstaande vier tabellen is weergegeven:

- De maximale geleiderbelasting in het globale assenstelsel, gesplitst in aandeel van back en ahead span
- De gecombineerde geleiderbelasting (Ba+Ah) in het globale assenstelsel met in het lokale assenstelsel de maximaal optredende trekkracht. Componenten Fx en Fy als absolute waarde
- De alledaagse (EDS) waarden van de gecombineerde geleiderbelastingen (Ba+Ah) met bijbehorende trekkrachten
- Controle op uplift, waar een negatieve waarde duidt op uplift

#### Maximale waarden voor back en ahead span

Geleider	Fx_ba [kN]	Fx_ah [kN]	Fy_ba [kN]	Fy_ah [kN]	Fz_ba [kN]	Fz_ah [kN]
bl1	-65,9	65,7	16,8	16,7	11,1	10,5
380ct1f1	-265,6	264,6	74,5	73,6	39,8	37,8
380ct1f2	-262,0	260,8	71,3	70,3	39,7	37,7
380ct1f3	-258,2	256,9	67,7	66,3	39,6	37,6
Post-isolato	0,0	0,0	0,0	0,0	0,0	
Post-isolato	0,0	0,0	0,0	0,0	0,0	
Post-isolato	0,0	0,0	0,0	0,0	0,0	
380ct2f1	-265,6	264,6	74,5	73,6	39,8	37,8
380ct2f2	-262,0	260,8	71,3	70,3	39,7	37,7
380ct2f3	-258,2	256,9	67,7	66,3	39,6	37,6
150ct3f1	-132,8	132,3	37,7	37,3	21,3	20,4
150ct3f2	-131,0	130,4	36,2	35,6	21,3	20,4
150ct3f3	-129,1	128,4	34,3	33,7	21,3	20,4
150ct4f1	-132,8	132,3	37,7	37,3	21,3	20,4
150ct4f2	-131,0	130,4	36,2	35,6	21,3	20,4
150ct4f3	-129,1	128,4	34,3	33,7	21,3	20,4
bl2	-65,0	64,8	16,7	16,5	11,0	10,5
Post-isolato	0,0	0,0	0,0	0,0	0,0	
Post-isolato	0,0	0,0	0,0	0,0	0,0	
Post-isolato	0,0	0,0	0,0	0,0	0,0	

#### Min. Weight span (m)

Weight spar Combinatie1

Geleider	SLS 1a	SLS 4	SLS 7
bl1	467,6	482,0	467,5
380ct1f1	467,5	480,5	467,5
380ct1f2	467,5	480,3	467,5
380ct1f3	467,5	480,0	467,5
Post-isolator 1			
Post-isolator 2			
Post-isolator 3			
380ct2f1	467,5	480,5	467,5
380ct2f2	467,5	480,3	467,5
380ct2f3	467,5	480,0	467,5
150ct3f1	467,5	480,5	467,5
150ct3f2	467,5	480,3	467,5
150ct3f3	467,5	480,0	467,5
150ct4f1	467,5	480,5	467,5
150ct4f2	467,5	480,3	467,5
150ct4f3	467,5	480,0	467,5
bl2	467,6	482,2	467,5
Post-isolator 4			
Post-isolator 5			
Post-isolator 6			

#### Max. Weight span (m)

Weight spar Combinatie1

Geleider	ULS 1a	ULS 3
bl1	548,6	453,7
380ct1f1	509,2	467,5
380ct1f2	505,5	466,5
380ct1f3	501,1	465,6
Post-isolator 1		
Post-isolator 2		
Post-isolator 3		
380ct2f1	509,2	467,5
380ct2f2	505,5	466,5
380ct2f3	501,1	465,6
150ct3f1	509,2	467,5
150ct3f2	505,5	466,5
150ct3f3	501,1	465,6
150ct4f1	509,2	467,5
150ct4f2	505,5	466,5
150ct4f3	501,1	465,6
bl2	550,8	453,4
Post-isolator 4		
Post-isolator 5		
Post-isolator 6		

Omhullende weight span over alle combinaties (incl. 0,9 combinaties)

#### Voor alle geleiders

Max. weight span	548,6 m
Min. weight span	166,8 m

#### Wind / Weight span verhouding

1,372 -
0,417 -

Project: RLL-TLB380  
 Masttype: HA+6\_c  
 Mast: 1078

**Maximale waarden back+ahead span      Maximale waarden trekkracht geleider**

Geleider	Fx	Fy	Fz	Ft_ba	Ft_ah
	[kN]	[kN]	[kN]	[kN]	[kN]
bl1	39,2	33,1	11,1	-67,8	67,6
380ct1f1	206,9	144,8	39,8	-272,7	271,5
380ct1f2	203,1	138,5	39,7	-268,8	267,5
380ct1f3	199,0	131,1	39,6	-264,7	263,3
Post-isolato	4,4	4,4	6,8	0,0	
Post-isolato	3,4	3,4	4,7	0,0	
Post-isolato	5,0	5,0	6,8	0,0	
380ct2f1	206,9	144,8	39,8	-272,7	271,5
380ct2f2	203,1	138,5	39,7	-268,8	267,5
380ct2f3	199,0	131,1	39,6	-264,7	263,3
150ct3f1	108,3	73,4	21,3	-136,3	135,8
150ct3f2	108,2	70,2	21,3	-134,4	133,8
150ct3f3	108,1	66,5	21,3	-132,3	131,6
150ct4f1	108,3	73,4	21,3	-136,3	135,8
150ct4f2	108,2	70,2	21,3	-134,4	133,8
150ct4f3	108,1	66,5	21,3	-132,3	131,6
bl2	38,6	32,8	11,0	-66,9	66,7
Post-isolato	4,4	4,4	6,8	0,0	
Post-isolato	3,4	3,4	4,7	0,0	
Post-isolato	5,0	5,0	6,8	0,0	

**EDS-belastingen geleiders**

Geleider	Fx	Fy	Fz	Ft_ba	Ft_ah
	[kN]	[kN]	[kN]	[kN]	[kN]
bl1	17,0	3,0	2,4	-17,2	17,2
380ct1f1	129,3	22,8	20,5	-131,3	131,3
380ct1f2	129,3	22,8	20,5	-131,3	131,3
380ct1f3	129,3	22,8	20,5	-131,3	131,3
Post-isolato	0,0	0,0	5,0	0,0	
Post-isolato	0,0	0,0	3,5	0,0	
Post-isolato	0,0	0,0	5,0	0,0	
380ct2f1	129,3	22,8	20,5	-131,3	131,3
380ct2f2	129,3	22,8	20,5	-131,3	131,3
380ct2f3	129,3	22,8	20,5	-131,3	131,3
150ct3f1	64,7	11,4	10,8	-65,7	65,7
150ct3f2	64,7	11,4	10,8	-65,7	65,7
150ct3f3	64,7	11,4	10,8	-65,7	65,7
150ct4f1	64,7	11,4	10,8	-65,7	65,7
150ct4f2	64,7	11,4	10,8	-65,7	65,7
150ct4f3	64,7	11,4	10,8	-65,7	65,7
bl2	16,5	2,9	2,3	-16,8	16,8
Post-isolato	0,0	0,0	5,0	0,0	
Post-isolato	0,0	0,0	3,5	0,0	
Post-isolato	0,0	0,0	5,0	0,0	

**Controle uplift SLS-wind**

Combinatie: Geleider	Fz_ba	Fz_ah
	[kN]	[kN]
SLS 4		
bl1	0,0	0,0
380ct1f1	0,0	0,0
380ct1f2	0,0	0,0
380ct1f3	0,0	0,0
Post-isolato	0,0	
Post-isolato	0,0	
Post-isolato	0,0	
380ct2f1	0,0	0,0
380ct2f2	0,0	0,0
380ct2f3	0,0	0,0
150ct3f1	0,0	0,0
150ct3f2	0,0	0,0
150ct3f3	0,0	0,0
150ct4f1	0,0	0,0
150ct4f2	0,0	0,0
150ct4f3	0,0	0,0
bl2	0,0	0,0
Post-isolato	0,0	
Post-isolato	0,0	
Post-isolato	0,0	

Project: RLL-TLB380  
 Masttype: HA+6\_c  
 Mast: 1078

**ULS-fundatiebelasting combinatie 1 en 3 wind haaks op de lijn of bissectrice en EDS, vanuit geleiders**

Combinatie	Combination	$F_x$ [kN]	$F_y$ [kN]	$F_z$ [kN]	$M_x$ [kNm]	$M_y$ [kNm]	$M_z$ [kNm]
ULS 1a_90		-27	1329	515	59913	-1151	0
ULS 1a_0,9_0		28	490	358	21843	1265	0
ULS 1a_0,9_0,9_90		-29	1289	223	58143	-1260	0
ULS 3_0		9	806	771	36230	413	0
SLS 7		0	422	403	18826	0	0

**ULS-fundatiebelasting combinatie 1 en 3 wind haaks op de lijn of bissectrice en EDS, totaal geleiders en mast**

Combinatie	$F_x$ [kN]	$F_y$ [kN]	$F_z$ [kN]	$M_x$ [kNm]	$M_y$ [kNm]	$M_z$ [kNm]
ULS 1a_90	-27	1739	1864	72098	-1151	0
ULS 1a_0,9_0,9_90	-29	1699	1235	70328	-1260	0
SLS 7	0	422	1527	18826	0	0

**Fundatiebelastingen, selectie belastingcombinaties op basis grootste waarde**

Combinatie	$F_x$ [kN]	$F_y$ [kN]	$F_z$ [kN]	$M_x$ [kNm]	$M_y$ [kNm]	$M_z$ [kNm]
ULS 1a_0,9_90	-27	1739	1329	<b>72099</b>	-1151	0
SPLS 3_80 Ah All Cts	-1886	512	1686	21492	<b>-84933</b>	9
SPLS 3_80 Ba Ct1	913	691	1787	30717	40649	<b>-9765</b>
SPLS 3_0,9_80 Ah All Cts	-1886	512	1239	<b>21493</b>	<b>-84933</b>	9

*Noot: grootste waarden kunnen in meerdere combinaties voorkomen, een combinatie is weergegeven.*

**Oplegreacties op fundering per randstijl**

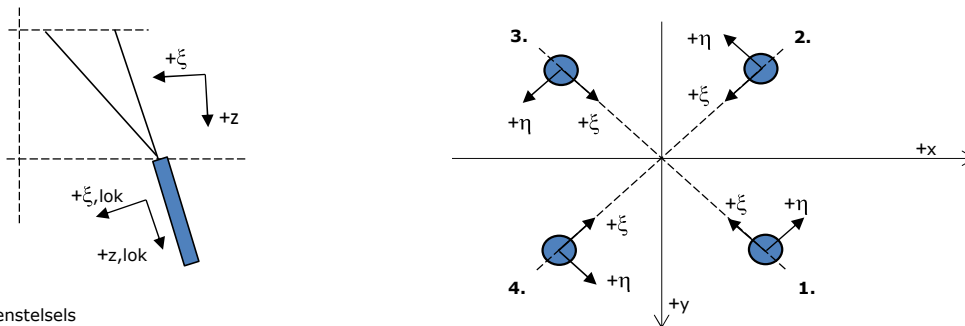

Assenstelsels

**Maximale drukbelasting**

Stijl	Combinatie	$R_x$ [kN]	$R_y$ [kN]	$R_z$ [kN]	$R_\eta$ [kN]	$R_\xi$ [kN]	$R_{\xi,lok}$ [kN]	$R_{z,lok}$ [kN]
1	SPLS 3_100 Ba All Cts	714	843	<b>4183</b>	-91	-1101	23	4332
2	SPLS 3_0 Ba All Cts	438	-598	<b>2750</b>	113	-733	6	2847
3	ULS 8 Ba	-428	-600	<b>2748</b>	-122	-727	12	2846
4	SPLS 3_80 Ah All Cts	-719	848	<b>4211</b>	91	-1108	23	4360

**Maximale trekbelasting**

Stijl	Combinatie	$R_x$ [kN]	$R_y$ [kN]	$R_z$ [kN]	$R_\eta$ [kN]	$R_\xi$ [kN]	$R_{\xi,lok}$ [kN]	$R_{z,lok}$ [kN]
1	SPLS 3_0,9_90 Ah All Cts	-250	-441	<b>-1956</b>	135	488	-37	-2026
2	SPLS 3_0,9_80 Ah All Cts	-567	695	<b>-3480</b>	-91	892	-43	-3603
3	SPLS 3_0,9_100 Ba All Cts	561	689	<b>-3448</b>	90	884	-43	-3571
4	SPLS 3_0,9_0 Ba All Cts	284	-445	<b>-2015</b>	-114	516	-26	-2087

**Maximale torsiebelasting (positief)**

Stijl	Combinatie	$R_x$ [kN]	$R_y$ [kN]	$R_z$ [kN]	$R_\eta$ [kN]	$R_\xi$ [kN]	$R_{\xi,lok}$ [kN]	$R_{z,lok}$ [kN]
1	SPLS 3_90 Ah Ct1	259	-221	35	<b>339</b>	-27	-18	36
2	SPLS 3_0,9_90 Ba Ct2	-87	-379	785	<b>330</b>	-207	4	813
3	SPLS 3_90 Ba Ct2	182	566	-2070	<b>272</b>	529	-28	-2143
4	SPLS 3_0,9_90 Ah Ct1	-364	734	2948	<b>261</b>	-776	16	3052

**Maximale torsiebelasting (negatief)**

Stijl	Combinatie	$R_x$ [kN]	$R_y$ [kN]	$R_z$ [kN]	$R_\eta$ [kN]	$R_\xi$ [kN]	$R_{\xi,lok}$ [kN]	$R_{z,lok}$ [kN]
1	SPLS 3_0,9_90 Ba Ct1	358	729	2916	<b>-262</b>	-769	15	3020
2	SPLS 3_90 Ah Ct2	-188	571	-2100	<b>-271</b>	536	-28	-2174
3	SPLS 3_0,9_90 Ah Ct2	82	-383	811	<b>-329</b>	-213	5	840
4	SPLS 3_90 Ba Ct1	-264	-217	60	<b>-340</b>	-33	-17	62

Project: RLL-TLB380  
 Masttype: HA+6\_c  
 Mast: 1078

#### Combinatie Ftrek+Fhor

Stijl	Combinatie	R <sub>x</sub> [kN]	R <sub>y</sub> [kN]	R <sub>z</sub> [kN]	R <sub>η</sub> [kN]	R <sub>ξ</sub> [kN]	R <sub>ξ,lok</sub> [kN]	R <sub>z,lok</sub> [kN]
1	SPLS 3_0,9_90 Ah All Cts	-250	-441	<b>-1956</b>	<b>135</b>	488	-37	-2026
2	SPLS 3_0,9_80 Ah All Cts	-567	695	<b>-3480</b>	<b>-91</b>	892	-43	-3603
3	SPLS 3_0,9_100 Ba All Cts	561	689	<b>-3448</b>	<b>90</b>	884	-43	-3571
4	SPLS 3_0,9_0 Ba All Cts	284	-445	<b>-2015</b>	<b>-114</b>	516	-26	-2087

#### Permanente belasting

Stijl	Combinatie	R <sub>x</sub> [kN]	R <sub>y</sub> [kN]	R <sub>z</sub> [kN]	R <sub>η</sub> [kN]	R <sub>ξ</sub> [kN]	R <sub>ξ,lok</sub> [kN]	R <sub>z,lok</sub> [kN]
1	SLS 7	220	185	1052	24	-287	-4	1089
2	SLS 7	-60	26	-289	24	61	-17	-299
3	SLS 7	60	26	-289	-24	61	-17	-299
4	SLS 7	-220	185	1052	-24	-287	-4	1089

#### Omhullenden ongeacht stijl

Belasting	Combinatie	R <sub>x</sub> [kN]	R <sub>y</sub> [kN]	R <sub>z</sub> [kN]	R <sub>η</sub> [kN]	R <sub>ξ</sub> [kN]	R <sub>ξ,lok</sub> [kN]	R <sub>z,lok</sub> [kN]
Max. druk	SPLS 3_80 Ah All Cts	-719	848	<b>4211</b>	91	-1108	23	4360
Max. trek	SPLS 3_0,9_80 Ah All Cts	-567	695	<b>-3480</b>	-91	892	-43	-3603
Max. pos. torsie	SPLS 3_90 Ah Ct1	259	-221	35	<b>339</b>	-27	-18	36
Max. neg. torsie	SPLS 3_90 Ba Ct1	-264	-217	60	<b>-340</b>	-33	-17	62
Comb. trek+torsie	SPLS 3_0,9_80 Ah All Cts	-567	695	<b>-3480</b>	<b>-91</b>	892	-43	-3603

#### Maximale trekbelasting SLS

Stijl	Combinatie	R <sub>x</sub> [kN]	R <sub>y</sub> [kN]	R <sub>z</sub> [kN]	R <sub>η</sub> [kN]	R <sub>ξ</sub> [kN]	R <sub>ξ,lok</sub> [kN]	R <sub>z,lok</sub> [kN]
1	SPLS 3_0,9_80 Ah All Cts	-247	-440	<b>-1949</b>	136	485	-39	-2018
2	SPLS 3_0,9_80 Ah All Cts	-567	695	<b>-3480</b>	-91	892	-43	-3603
3	SPLS 1a_0,9_100 Ba Ct2	256	582	<b>-2291</b>	231	593	-23	-2372
4	SPLS 3_0,9_100 Ba Ct2	119	95	<b>-150</b>	151	17	-24	-155

#### Maximale drukbelasting SLS

Stijl	Combinatie	R <sub>x</sub> [kN]	R <sub>y</sub> [kN]	R <sub>z</sub> [kN]	R <sub>η</sub> [kN]	R <sub>ξ</sub> [kN]	R <sub>ξ,lok</sub> [kN]	R <sub>z,lok</sub> [kN]
1	SPLS 1a_100 Ba Ct2	710	443	<b>3035</b>	189	-815	1	3143
2	SPLS 3_100 Ba Ct2	-53	-406	<b>948</b>	325	-250	5	982
3	SPLS 3_80 Ah All Cts	-400	-592	<b>2680</b>	-136	-701	19	2776
4	SPLS 3_80 Ah All Cts	-719	848	<b>4211</b>	91	-1108	23	4360

Project: RLL-TLB380  
Masttype: HA+6\_c  
Mast: 1078

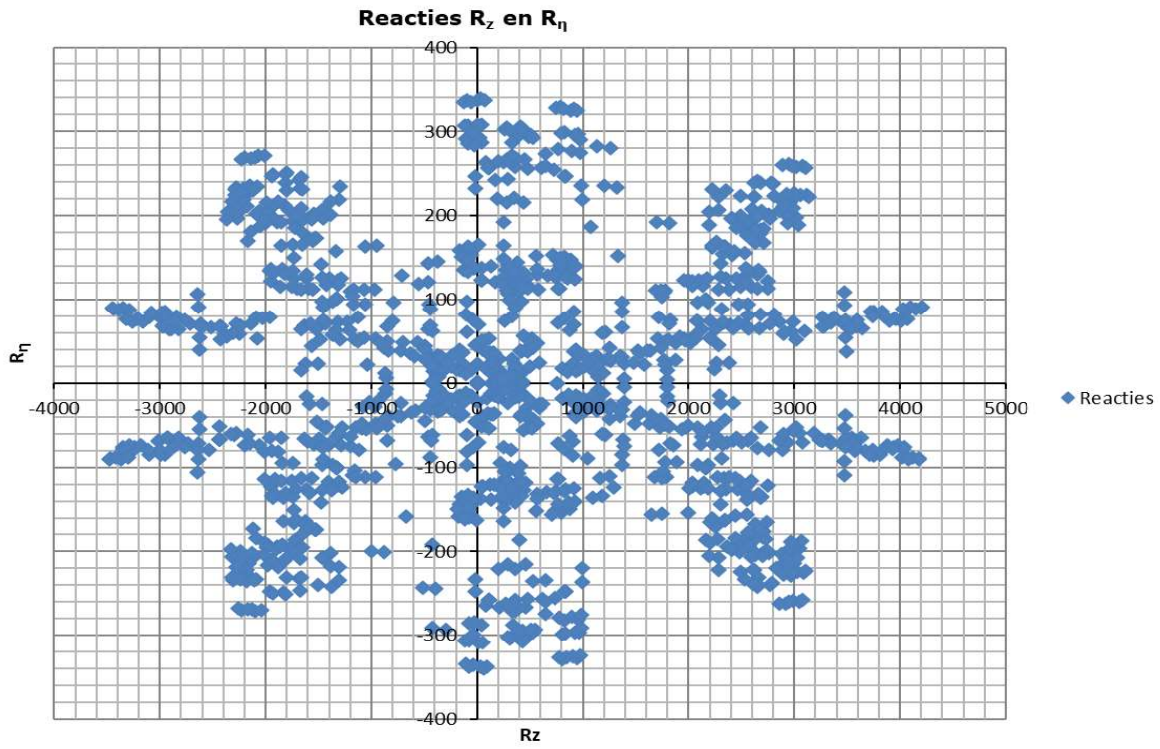





Project: RLL-TLB380  
 Tower: HA+6\_c - bouwfase  
 Number: 1078

Auteur: TBR  
 Versie: v12.0

### Geleiderbelastingen

#### Algemeen

Benaming HA+6\_c - bouwfase  
 Masttype Hoekmast  
 Aantal circuits 2  
 Configuratie 2-circuit-verticaal  
 Aantal bliksemgeleiders 1

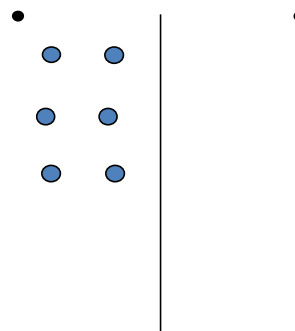

#### Uitgangspunten

Norm NEN-EN50341-2-15:2019  
 Gevolgklasse initieel CC2  
 Betrouwbaarheidsniveau initieel Nieuwbouw  
 Referentieperiode initieel 15 jaar  
 CC2  
 Betrouwbaarheidsniveau na aanpassing n.v.t.  
 15 jaar  
 Windgebied III  
 Windsnelheid (m/s) 24,5 m/s  
 Terreincategorie II  
 Reductiefactor  $C_{dir}$  1,00  
 IJsg gebied fasegeleider B  
 IJsg gebied bliksemgeleider A

#### Geleiders Back

Omschrijving	Spanning	Geleider Back	Bundel Ba	IJsg gebied	Toeslag gewicht	Toeslag diameter	Intrekwaarden $P_{back}$
Circuit 1	380 kV	AAAC-AL7 620	4	B	3 %	3 %	1800
Circuit 2	150 kV	AAAC-AL7 620	2	B	3 %	3 %	1800
Bliksemdraad 1		AACSR 241-AL3-39-A20SA	1	A	2 %	2 %	1800

#### Geleiders Ahead

Omschrijving	Spanning	Geleider Ahead	Bundel Ah	IJsg gebied	Toeslag gewicht	Toeslag diameter	Intrekwaarden $P_{ahead}$
Circuit 1	380 kV	AAAC-AL7 620	4	B	3 %	3 %	1800
Circuit 2	150 kV	AAAC-AL7 620	2	B	3 %	3 %	1800
Bliksemdraad 1		AACSR 241-AL3-39-A20SA	1	A	2 %	2 %	1800

#### Isolatoren (1)

Omschrijving	Ophanging	Gewicht [kN]	Lengte [m]	Windopp. [m <sup>2</sup> ]
Circuit 1	Afspanketting	3,00	6,50	1,10
Circuit 2	Afspanketting	3,00	6,50	1,10
Bliksemdraad 1	Afspanketting	0,10	0,20	0,10

1. Eigenschappen gelden voor geheel van de isolatorset

#### Ophanghoogte en positie in mast

Circuits	Aanduiding	Nummer	Ophanghoogte	Aangrijppunt	Positie in mast Horizontale afstand
Circuit 1	10	380ct1f1	54,0 m	54,0 m	-10,8 m
Circuit 1	11	380ct1f2	44,0 m	44,0 m	-14,3 m
Circuit 1	12	380ct1f3	34,5 m	34,5 m	-11,4 m
Circuit 2	20	150ct2f1	54,0 m	54,0 m	-4,3 m
Circuit 2	21	150ct2f2	44,0 m	44,0 m	-7,8 m
Circuit 2	22	150ct2f3	34,5 m	34,5 m	-4,9 m
Bliksemdraad 1	1	bl1	59,1 m	59,1 m	-16,2 m

Project: RLL-TLB380  
 Tower: HA+6\_c - bouwfase  
 Number: 1078

**Hoogteaanpassing naastgelegen masten** (aanpassing wind- en weight span)

	Back	Ahead	
Verhoging voor windbelasting	12,0 m	6,0 m	(positief: omhoog)
Verlaging voor verticale belasting	-9,0 m	-6,0 m	(negatief: omlaag, grotere weight span)
Verlaging:	Niet in 0,9EG-combinaties		

**Hoogteafwijking mastbeeld naastgelegen masten en richtingsverandering t.o.v. Lijnrichting**

Circuits	Aanduiding	Nummer	Hoogteverschil		Richtingsverandering	
			$\Delta h$ back	$\Delta h$ ahead	$\Delta y$ back	$\Delta y$ ahead
Circuit 1	10	380ct1f1	0,0	0,0 m	0,0	0,0 m
Circuit 1	11	380ct1f2	0,0	0,0 m	0,0	0,0 m
Circuit 1	12	380ct1f3	0,0	0,0 m	0,0	0,0 m
Circuit 2	20	150ct2f1	0,0	0,0 m	0,0	0,0 m
Circuit 2	21	150ct2f2	0,0	0,0 m	0,0	0,0 m
Circuit 2	22	150ct2f3	0,0	0,0 m	0,0	0,0 m
Bliksemdraad 1	1	bl1	0,0	0,0 m	0,0	0,0 m

**Lijn- en mastgegevens**

	Back	Ahead
Ruling span $\sqrt{(\Sigma L^3)/\Sigma L}$	400,0	400,0 m
Lijnhoek $\beta$	160 °	
Rotatie mast t.o.v. bissectrice $\theta$	0 °	
Vaklengte	400	400 m
Hoogte onderkant mast t.o.v. maaiveld	0,5 m	
Beschouwde windrichtingen	0 °	
Windrichtingen volgens:	45 °	
<i>Geleiderbelastingen</i>	90 °	
	135 °	
	80 °	
	100 °	

Windrichtingen gelden t.o.v. hoofdrichting mastconstructie, niet t.o.v. bissectrice.

Windrichtingen en positieve richtingen belastingen

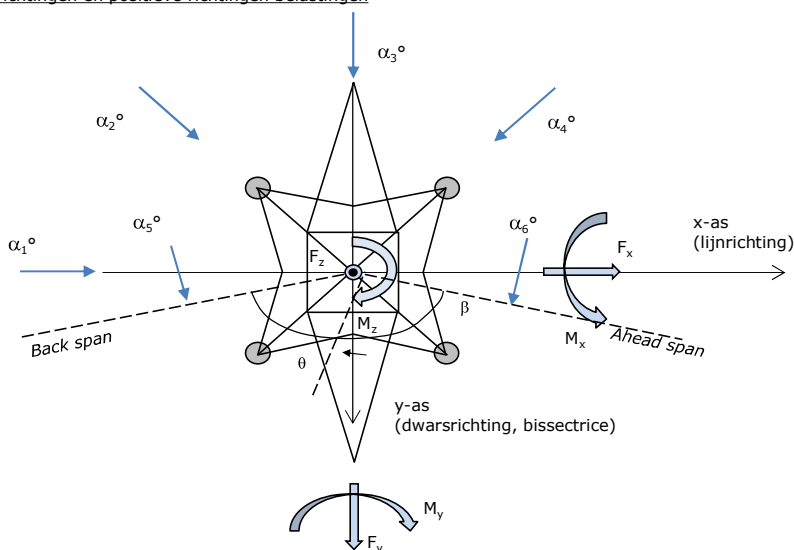

**Beschouwd aantal windrichtingen**

1a	6
3	6
4	1
6	1
Overig	1

Project: RLL-TLB380  
 Tower: HA+6\_c - bouwfase  
 Number: 1078

### Geleiderafval

		SPLS - torsie		SPLS - Enkelzijdige trek		5a - geleiderbreuk	
		Aanw.	Afw.	Aanw.	Afw.	Aanw.	Afw.
Circuit 1	380ct1f1	1	0	1	0	1	0
Circuit 1	380ct1f2	1	0	1	0	1	0
Circuit 1	380ct1f3	1	0	1	0	1	0
Circuit 2	150ct2f1	0	1	1	0	1	0
Circuit 2	150ct2f2	0	1	1	0	1	0
Circuit 2	150ct2f3	0	1	1	0	1	0
Bliksemdraad 1	bl1	1	0	1	0	1	0

### Belastingssituaties SPLS

Beschouwde situaties SPLS: 1 t/m 6, alle mogelijke situaties.

Principe belastingssituaties:

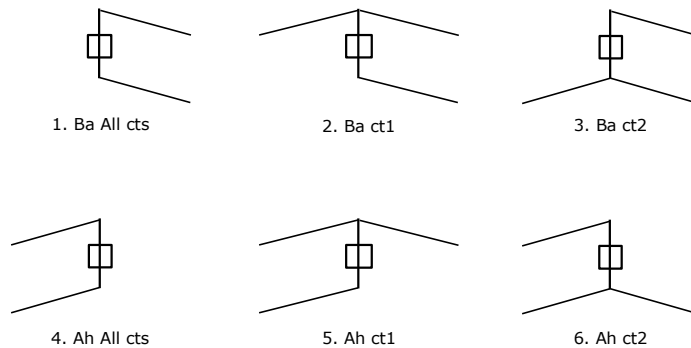

### Belastingssituaties 5a. Geleiderbreuk

Beschouwde situaties geleiderbreuk 5a: 1 en 2, alle mogelijke situaties.

Principe belastingssituaties:

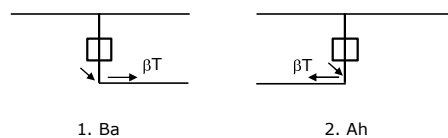

Project: RLL-TLB380  
 Tower: HA+6\_c - bouwfase  
 Number: 1078

### Belastingsituaties 6. Bouw- en onderhoud

Onder 6a wordt de belasting door aanwezigheid lijnwagen of lijnfiets in combinatie met puntlast op traverse in rekening gebracht. Combinatie 6b bevat geen belastingen in geleider of op traverse. Deze combinatie is toegevoegd om te kunnen combineren met separate controle bordessen etc. De situaties worden in ULS en in iedere SPLS-situatie (in geval van hoekmast) toegepast.

	Fase	Bliksem
Lijnwagen	4,0 kN	2,0 kN
Puntlast op traverse	1,0 kN	1,0 kN

Beschouwde situaties bouw- en onderhoud 6a: 1 t/m 4, alle mogelijke situaties.

Aanwezigheid lijnwagen: Circuit, belasting tegelijk aanwezig in alle geleiders per circuit.

Principe belastingssituaties:

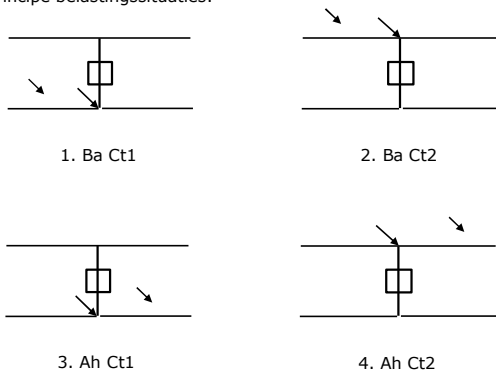

### Belastingsituaties 8. Lijndansen als statische belasting

Geleider		
Steunmast fase	0,866 W	1,5 W
Steunmast bliksem	1,5 EDS	1,5 W
Hoekmast fase en bliksem	1,5 EDS	1,5 W

Beschouwde situaties lijndansen 8: 1 en 2, alle mogelijke situaties.

Belasting tegelijk aanwezig in alle geleiders van het circuit.

Principe belastingssituaties:

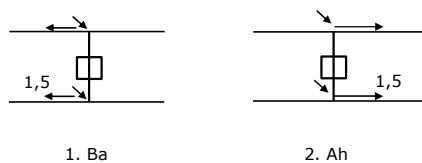

### Belastingcombinatie 8. Lijndansen als dynamische belasting

Alleen van toepassing op hoek- en eindmasten

Belasting bestaat uit EDS-trekbelasting in één van de geleiders aan één zijde van de mast

Door gebruiker via het belastingspectrum van tabel 4.11/NL.1 om te zetten naar spanningspectrum

Project: RLL-TLB380  
 Tower: HA+6\_c - bouwfase  
 Number: 1078

## Mastconstructie

### Eigenschappen

Masttype	Hoekmast	
Mastbenaming	HA+6_c - bouwfase	
Voetplaat t.o.v. maaiveld	0,5 m	
Masthoogte t.o.v. voetplaat	59,1 m	
Gewicht mast	1124,0 kN	
<i>Breedte en helling mast bij fundatie</i>	x-ri.	y-ri.
Pootsprei	14,04	14,04 m
Helling van de randstijl	0,190	0,190 -
Factor spatkracht	1,1	1,1 -

### Berekening windbelasting

Dynamische invloed $G_T$	1,00 (Masthoogte < 60 m)
Windbelasting overhoeks op mastlichaam evenredig met:	$(A1C1\sin^2(\phi)+A2C2\cos^2(\phi))$
Windbelasting overhoeks op traverse evenredig met:	$(A1C1\sin^2(\phi)+A2C2\cos^2(\phi))$
Vergroting wind overhoeks mastlichaam	$(1+0,2\sin^2(2\phi))$
Vergroting wind overhoeks traverse	$(1+0,2\sin^2(2\phi))$
Factor wind evenwijdig t.o.v. haaks op traverse	0,4

### Eigenschappen mastsecties langsrichting (vooraanzicht, yz-vlak)

Omschrijving	h [m]	b <sub>1</sub> [m]	b <sub>2</sub> [m]	Δh [m]	Δ <sub>x</sub> [m]	A <sub>0</sub> [m <sup>2</sup> ]	A <sub>1</sub> [m <sup>2</sup> ]	χ = A <sub>1</sub> /A <sub>0</sub> [-]	C <sub>t</sub>
Broekstuk	21,40	14,04	5,91	21,40	0,190	213,49	48,90	0,23	2,81
Eerste tussenstuk	28,20	5,91	5,23	6,80	0,050	37,88	13,24	0,35	2,37
Tweede tussenstuk	34,50	5,23	4,60	6,30	0,050	30,96	10,25	0,33	2,43
Bovenstuk 1	44,00	4,60	3,65	9,50	0,050	39,19	11,88	0,30	2,52
Bovenstuk 2	57,40	3,65	2,31	13,40	0,050	39,93	13,01	0,33	2,45
Topstuk	59,10	2,31		1,70		1,96	0,33	0,17	3,08
Ondertraverse	34,50	9,40		3,10		14,57	4,37	0,30	2,54
Middentraverse	44,00	12,78		3,20		20,45	6,34	0,31	2,50
Boventraverse	54,00	14,88		5,10		37,93	7,34	0,19	2,96

### Eigenschappen mastsecties dwarsrichting (zijaanzicht, xz-vlak)

Omschrijving	h [m]	b <sub>1</sub> [m]	b <sub>2</sub> [m]	Δh [m]	Δ <sub>x</sub> [m]	A <sub>0</sub> [m <sup>2</sup> ]	A <sub>1</sub> [m <sup>2</sup> ]	χ = A <sub>1</sub> /A <sub>0</sub> [-]	C <sub>t</sub>
Broekstuk	21,40	14,04	5,91	21,40	0,190	213,49	48,90	0,23	2,81
Eerste tussenstuk	28,20	5,91	5,23	6,80	0,050	37,88	13,24	0,35	2,37
Tweede tussenstuk	34,50	5,23	4,60	6,30	0,050	30,96	10,25	0,33	2,43
Bovenstuk 1	44,00	4,60	3,65	9,50	0,050	39,19	11,88	0,30	2,52
Bovenstuk 2	57,40	3,65	2,31	13,40	0,050	39,93	13,01	0,33	2,45
Topstuk	59,10	2,31		1,70		1,96	0,33	0,17	3,08
Ondertraverse	34,50	9,40		3,10		14,57	4,37	0,30	2,54
Middentraverse	44,00	12,78		3,20		20,45	6,34	0,31	2,50
Boventraverse	54,00	14,88		5,10		37,93	7,34	0,19	2,96

NB: oppervlakte traverse dwarsrichting van de tabel wordt in berekening gereduceerd.  
 NB: oppervlakte traverse per zijde, dus helft van totaal van twee traveres.

Project: RLL-TLB380  
 Tower: HA+6\_c - bouwfase  
 Number: 1078

#### Windoppervlak feeders telecominstallaties

Onderdeel	A (m <sup>2</sup> /m)	Factor	Δh	A <sub>1</sub>
Broekstuk	0,14	0,71	21,4	2,1
Eerste tussenstuk	0,14	0,71	6,8	0,7
Tweede tussenstuk	0,14	0,71	6,3	0,6
Bovenstuk 1	0,14	0,71	9,5	0,9
Bovenstuk 2				

#### Invoer antennes

Omschrijving	A (m <sup>2</sup> )	h (m)	C <sub>i</sub> (m)
Antenne top			
Antenne o.t.	4,7	40,7	1,5

#### Belastingen mastsectie langsrichting (x-richting) per windrichting

Omschrijving	P <sub>w</sub> [kN/m <sup>2</sup> ]	F <sub>x1</sub> [kN]	F <sub>x2</sub> [kN]	F <sub>x3</sub> [kN]	F <sub>x4</sub> [kN]	h <sub>ef</sub> [m]	M <sub>y1</sub> [kNm]	M <sub>y2</sub> [kNm]	M <sub>y3</sub> [kNm]	M <sub>y4</sub> [kNm]
Broekstuk	0,72	98,5	83,6	0,0	-83,6	10,7	1054,1	894,4	0,0	-894,4
Eerste tussenstuk	0,94	29,3	24,9	0,0	-24,9	24,8	727,4	617,3	0,0	-617,3
Tweede tussenstuk	1,00	24,9	21,1	0,0	-21,1	31,4	780,8	662,5	0,0	-662,5
Bovenstuk 1	1,07	32,0	27,2	0,0	-27,2	39,3	1257,3	1066,9	0,0	-1066,9
Bovenstuk 2	1,14	36,3	30,8	0,0	-30,8	50,7	1837,9	1559,5	0,0	-1559,5
Topstuk	1,18	1,2	1,0	0,0	-1,0	58,3	69,6	59,1	0,0	-59,1
Ondertraverse	1,04	22,9	13,6	0,0	-13,6	35,5	815,3	484,2	0,0	-484,2
Middentraverse	1,10	35,0	20,8	0,0	-20,8	45,1	1578,4	937,5	0,0	-937,5
Boventraverse	1,17	50,7	30,1	0,0	-30,1	55,7	2825,4	1678,2	0,0	-1678,2
<b>Totaal</b>		<b>330,9</b>	<b>253,1</b>	<b>0,0</b>	<b>-253,1</b>		<b>10946,2</b>	<b>7959,6</b>	<b>0,0</b>	<b>-7959,6</b>

#### Belastingen mastsectie dwarsrichting (y-richting) per windrichting

Omschrijving	P <sub>w</sub> [kN/m <sup>2</sup> ]	F <sub>y1</sub> [kN]	F <sub>y2</sub> [kN]	F <sub>y3</sub> [kN]	F <sub>y4</sub> [kN]	h <sub>ef</sub> [m]	M <sub>x1</sub> [kNm]	M <sub>x2</sub> [kNm]	M <sub>x3</sub> [kNm]	M <sub>x4</sub> [kNm]
Broekstuk	0,72	0,0	83,6	98,5	83,6	10,7	0,0	894,4	1054,1	894,4
Eerste tussenstuk	0,94	0,0	24,9	29,3	24,9	24,8	0,0	617,3	727,4	617,3
Tweede tussenstuk	1,00	0,0	21,1	24,9	21,1	31,4	0,0	662,5	780,8	662,5
Bovenstuk 1	1,07	0,0	27,2	32,0	27,2	39,3	0,0	1066,9	1257,3	1066,9
Bovenstuk 2	1,14	0,0	30,8	36,3	30,8	50,7	0,0	1559,5	1837,9	1559,5
Topstuk	1,18	0,0	1,0	1,2	1,0	58,3	0,0	59,1	69,6	59,1
Ondertraverse	1,04	0,0	13,6	9,2	13,6	35,5	0,0	484,2	326,1	484,2
Middentraverse	1,10	0,0	20,8	14,0	20,8	45,1	0,0	937,5	631,3	937,5
Boventraverse	1,17	0,0	30,1	20,3	30,1	55,7	0,0	1678,2	1130,2	1678,2
<b>Totaal</b>		<b>0,0</b>	<b>253,1</b>	<b>265,7</b>	<b>253,1</b>		<b>0,0</b>	<b>7959,6</b>	<b>7814,8</b>	<b>7959,6</b>

#### Resulterende belastingen vanuit mastconstructie incl. antenne zonder geleiders niveau fundatie (kar. waarde)

Belasting / windrichting	F <sub>x</sub> [kN]	F <sub>y</sub> [kN]	F <sub>z</sub> [kN]	M <sub>x</sub> [kNm]	M <sub>y</sub> [kNm]	M <sub>z</sub> [kNm]
Permanente belasting	0	0	1124	0	0	0
Windrichting 0°	339	0	0	0	11255	0
Windrichting 45°	258	258	0	8178	8178	0
Windrichting 90°	0	273	0	8123	0	0
Windrichting 135°	-258	258	0	8178	-8178	0

Project: RLL-TLB380  
 Tower: HA+6\_c - bouwfase  
 Number: 1078

### Tussenresultaten geleiderbelastingen

#### Geleiders back

Circuit	Geleider	Diameter [mm]	A [mm <sup>2</sup> ]	G [N/m]	E [N/mm <sup>2</sup> ]	$\alpha T$ [-]
Circuit 1	AAAC-AL7 620	32,4	621,0	17,71	56000	2,30E-05
Circuit 2	AAAC-AL7 620	32,4	621,0	17,71	56000	2,30E-05
Bliksemdraad 1	AACSR 241-AL3-39-A20SA	21,8	281,0	9,38	70165	1,97E-05

#### Geleiders ahead

Circuit	Geleider	Diameter [mm]	A [mm <sup>2</sup> ]	G [N/m]	E [N/mm <sup>2</sup> ]	$\alpha T$ [-]
Circuit 1	AAAC-AL7 620	32,4	621,0	17,71	56000	2,30E-05
Circuit 2	AAAC-AL7 620	32,4	621,0	17,71	56000	2,30E-05
Bliksemdraad 1	AACSR 241-AL3-39-A20SA	21,8	281,0	9,38	70165	1,97E-05

#### Verticale belasting back

Circuit	Bundel [-]	Toeslag [%]	$W_{z,G}$ [N/m]	IJsgebied	Formule	$W_{z,ijs}$ [N/m]	$W_{z,ijs,bundel}$ [N/m]
Circuit 1	4	3	73,0	B	4+0,2d	10,5	41,9
Circuit 2	2	3	36,5	B	4+0,2d	10,5	21,0
Bliksemdraad 1	1	2	9,6	A	15+0,4d	23,7	23,7

#### Verticale belasting ahead

Circuit	Bundel [-]	Toeslag [%]	$W_{z,G}$ [N/m]	IJsgebied	Formule	$W_{z,ijs}$ [N/m]	$W_{z,ijs,bundel}$ [N/m]
Circuit 1	4	3	73,0	B	4+0,2d	10,5	41,9
Circuit 2	2	3	36,5	B	4+0,2d	10,5	21,0
Bliksemdraad 1	1	2	9,6	A	15+0,4d	23,7	23,7

#### Isolatoren

Geleider	$G_{isolator}$ [kN]	Aantal	$F_{v,iso}$ [kN]	Lengte [m]	Windopp. [m <sup>2</sup> ]	Windhoogte [m]	Stuwdruk [kN/m <sup>2</sup> ]	Vormfactor [-]	$F_{h,iso}$ [kN]
380ct1f1	3,00	1	3	6,5	1,1	54,50	1,16	1,2	1,53
380ct1f2	3,00	1	3	6,5	1,1	44,50	1,10	1,2	1,45
380ct1f3	3,00	1	3	6,5	1,1	35,00	1,03	1,2	1,36
150ct2f1	3,00	1	3	6,5	1,1	54,50	1,16	1,2	1,53
150ct2f2	3,00	1	3	6,5	1,1	44,50	1,10	1,2	1,45
150ct2f3	3,00	1	3	6,5	1,1	35,00	1,03	1,2	1,36
bl1	0,10	1	0,1	0,2	0,1	59,60	1,19	1,2	0,14



Project: RLL-TLB380  
 Tower: HA+6\_c - bouwfase  
 Number: 1078

#### Windbelasting back

Geleider	hoogte		$G_{c\_dwars}$	$G_{c\_trek}$	$C_c$	$d_{toeslag}$	$W_y$	$W_{y,vak}$	$D_{ijs,toeslag}$	$W_{y,ijs}$	$W_{y,ijs,vak}$
	wind [m]	Stuwdruk [kN/m <sup>2</sup> ]									
380ct1f1	53,1	1,15	0,62	0,68	0,95	33,37	91,4	100,4	51,8	178,5	196,2
380ct1f2	43,1	1,09	0,61	0,67	0,97	33,37	85,9	94,5	51,8	164,5	181,0
380ct1f3	33,6	1,02	0,59	0,65	1,00	33,37	79,5	87,5	51,8	148,8	163,8
150ct2f1	53,1	1,15	0,62	0,68	0,95	33,37	45,7	50,2	51,8	89,2	98,1
150ct2f2	43,1	1,09	0,61	0,67	0,97	33,37	42,9	47,2	51,8	82,3	90,5
150ct2f3	33,6	1,02	0,59	0,65	1,00	33,37	39,7	43,7	51,8	74,4	81,9
bl1	58,2	1,18	0,63	0,69	1,18	22,24	19,4	21,3	63,1	56,3	61,8

#### Windbelasting ahead

Geleider	hoogte		$G_{c\_dwars}$	$G_{c\_trek}$	$C_c$	$d_{toeslag}$	$W_y$	$W_{y,vak}$	$D_{ijs,toeslag}$	$W_{y,ijs}$	$W_{y,ijs,vak}$
	wind [m]	Stuwdruk [kN/m <sup>2</sup> ]									
380ct1f1	50,1	1,14	0,62	0,68	0,96	33,37	89,8	98,8	51,8	174,5	191,9
380ct1f2	40,1	1,07	0,60	0,66	0,98	33,37	84,0	92,4	51,8	159,9	175,9
380ct1f3	30,6	0,99	0,58	0,64	1,00	33,37	77,1	84,9	51,8	143,2	157,6
150ct2f1	50,1	1,14	0,62	0,68	0,96	33,37	44,9	49,4	51,8	87,3	95,9
150ct2f2	40,1	1,07	0,60	0,66	0,98	33,37	42,0	46,2	51,8	79,9	88,0
150ct2f3	30,6	0,99	0,58	0,64	1,00	33,37	38,6	42,4	51,8	71,6	78,8
bl1	55,2	1,17	0,62	0,69	1,18	22,24	19,1	21,0	63,1	55,2	60,6

NB: belastingen  $w_v$  gelden voor bundel

Project: RLL-TLB380  
 Masttype: HA+6\_c - bouwfase  
 Mast: 1078

Auteur: TBR  
 Versie: v12.0

**Geleiderbelastingen**

**Uitgangspunten**  
 Betrouwbaarheidsniveau Nieuwbouw CC2  
 Referentieperiode 15 jaar

<b>ULS</b> (bezwijksterkte)		<b>NEN-EN50341-2-15:2019</b>							
Belastingsgeval	omschrijving	Temp °C	$\gamma_G$		$\gamma_Q$			$\gamma_a$ $A_k$	
			$G_{k,mast}$	$G_{k,geleider}$	$Q_{pk}$	$Q_{wk}$	$Q_{ik}$		
ULS 1a	Wind	10°	1,20	1,20	0,00	1,25	0,00	0,0	
ULS 1a_0,9	Wind 0,9Gk alleen mast	10°	0,90	1,20	0,00	1,25	0,00	0,0	
ULS 1a_0,9_0,9	Wind 0,9Gk ook geleider	10°	0,90	0,90	0,00	1,25	0,00	0,0	
ULS 3	Wind+ijs	-5°	1,20	1,20	0,00	0,38	1,07	0,0	
ULS 3_0,9	Wind+ijs 0,9	-5°	0,90	1,20	0,00	0,38	1,07	0,0	
ULS 4	Koude+wind	-20°	1,20	1,20	0,00	0,25	0,00	0,0	
ULS 4_0,9	Koude+wind 0,9	-20°	0,90	1,20	0,00	0,25	0,00	0,0	
ULS 5a	Torsiebelastingen	10°	1,00	1,00	1,00	0,00	0,00	1,0	
ULS 5b	Longitudinale belastingen	10°	1,00	1,00	0,00	0,00	0,00	1,0	
ULS 6	Bouw en onderhoud	5°	1,20	1,20	1,50	0,25	0,00	0,0	
ULS 6_0,9	Bouw en onderhoud	5°	1,20	1,20	0,00	0,25	0,00	0,0	
ULS 7	Permanent	10°	1,35	1,35	0,00	0,00	0,00	0,0	
ULS 8	Special	10°	1,00	1,00	0,00	0,00	0,00	1,0	
<b>SPLS</b> (Bezwijksterkte, enkel voor hoekmasten: afwezigheid geleiders)			$\gamma_G$		$\gamma_Q$				
			$G_k$	$G_k$	$Q_{pk}$	$Q_{wk}$	$Q_{ik}$	$A_k$	
SPLS 1a	Wind	10°	1,20	1,20	0,0	0,78	0,00	0,0	
SPLS 1a_0,9	Wind 0,9	10°	0,90	1,20	0,0	0,78	0,00	0,0	
SPLS 1a_0,9_0,9	Wind 0,9	10°	0,90	0,90	0,0	0,78	0,00	0,0	
SPLS 3	Wind+ijs	-5°	1,20	1,20	0,0	0,36	0,34	0,0	
SPLS 3_0,9	Wind+ijs 0,9	-5°	0,90	1,20	0,0	0,36	0,34	0,0	
SPLS 4	Koude+wind	-20°	1,20	1,20	0,0	0,24	0,00	0,0	
SPLS 4_0,9	Koude+wind 0,9	-20°	0,90	1,20	0,0	0,24	0,00	0,0	
SPLS 6	Bouw en onderhoud	5°	1,20	1,20	1,2	0,24	0,0	0,0	
SPLS 6_0,9	Bouw en onderhoud	5°	1,20	1,20	0,0	0,24	0,0	0,0	
<b>SLS</b> (controle van de vervormingen, vermoeiing, EDS)			$G_k$		$Q_{pk}$			$A_k$	
			$G_k$	$G_k$	$Q_{pk}$	$Q_{wk}$	$Q_{ik}$	$A_k$	
SLS 1a	Wind	10°	1,00	1,00	0,0	0,87	0,0	0,0	
SLS 3	Wind+ijs	-5°	1,00	1,00	0,0	0,26	0,71	0,0	
SLS 4	Wind	-20°	1,00	1,00	0,0	0,17	0,0	0,0	
SLS 6	Bouw en onderhoud	5°	1,00	1,00	0,0	0,17	0,0	0,0	
SLS 7	PB (EDS, geen wind)	10°	1,00	1,00	0,0	0,00	0,0	0,0	

Aantal windrichtingen 6  
 Aantal belastingcombinaties ULS 68  
 Aantal belastingcombinaties SPLS 222  
 Aantal belastingcombinaties SLS 15  
 Aantal knooplasten 5185

Project: RLL-TLB380  
 Masttype: HA+6\_c - bouwfase  
 Mast: 1078

### Samenvattingstabellen geleiderbelastingen

In de onderstaande vier tabellen is weergegeven:

- De maximale geleiderbelasting in het globale assenstelsel, gesplitst in aandeel van back en ahead span
- De gecombineerde geleiderbelasting (Ba+Ah) in het globale assenstelsel met in het lokale assenstelsel de maximaal optredende trekkracht. Componenten Fx en Fy als absolute waarde
- De alledaagse (EDS) waarden van de gecombineerde geleiderbelastingen (Ba+Ah) met bijbehorende trekkrachten
- Controle op uplift, waar een negatieve waarde duidt op uplift

#### Maximale waarden voor back en ahead span

Geleider	Fx_ba [kN]	Fx_ah [kN]	Fy_ba [kN]	Fy_ah [kN]	Fz_ba [kN]	Fz_ah [kN]
bl1	-54,0	53,8	13,9	13,7	8,2	7,8
380ct1f1	-239,7	238,8	65,4	64,7	35,6	33,8
380ct1f2	-236,6	235,7	62,8	61,9	35,5	33,7
380ct1f3	-233,4	232,4	59,8	58,7	35,5	33,7
Post-isolato	0,0	0,0	0,0	0,0	0,0	
Post-isolato	0,0	0,0	0,0	0,0	0,0	
Post-isolato	0,0	0,0	0,0	0,0	0,0	
150ct2f1	-119,8	119,3	33,7	33,3	22,5	21,6
150ct2f2	-118,3	117,8	32,4	31,9	22,5	21,6
150ct2f3	-116,7	116,1	30,8	30,3	22,5	21,6

#### Min. Weight span (m)

Weight spar Combinatie1

Geleider	SLS 1a	SLS 4	SLS 7
bl1	467,6	480,7	467,5
380ct1f1	467,5	480,0	467,5
380ct1f2	467,5	479,8	467,5
380ct1f3	467,5	479,6	467,5
Post-isolator 1			
Post-isolator 2			
Post-isolator 3			
150ct2f1	467,5	480,0	467,5
150ct2f2	467,5	479,8	467,5
150ct2f3	467,5	479,6	467,5

#### Max. Weight span (m)

Weight spar Combinatie1

Geleider	ULS 1a	ULS 3
bl1	532,3	460,2
380ct1f1	499,2	469,1
380ct1f2	496,2	468,2
380ct1f3	492,6	467,3
Post-isolator 1		
Post-isolator 2		
Post-isolator 3		
150ct2f1	499,2	469,1
150ct2f2	496,2	468,2
150ct2f3	492,6	467,3

Omhullende weight span over alle combinaties (incl. 0,9 combinaties)

Voor alle geleiders

Max. weight span 532,3 m  
 Min. weight span 194,1 m

Wind / Weight span verhouding

1,331 -  
 0,485 -

Project: RLL-TLB380  
 Masttype: HA+6\_c - bouwfase  
 Mast: 1078

**Maximale waarden back+ahead span      Maximale waarden trekkracht geleider**

Geleider	Fx	Fy	Fz	Ft_ba	Ft_ah
	[kN]	[kN]	[kN]	[kN]	[kN]
bl1	39,2	27,2	8,2	-55,6	55,3
380ct1f1	206,9	127,4	35,6	-245,8	244,9
380ct1f2	203,1	122,2	35,5	-242,6	241,5
380ct1f3	199,0	116,1	35,5	-239,1	237,9
Post-isolato	3,7	3,7	6,8	0,0	
Post-isolato	2,8	2,8	4,7	0,0	
Post-isolato	4,2	4,2	6,8	0,0	
150ct2f1	108,3	65,5	22,5	-122,9	122,4
150ct2f2	108,2	63,0	22,5	-121,3	120,8
150ct2f3	108,1	59,9	22,5	-119,6	119,0

**EDS-belastingen geleiders**

Geleider	Fx	Fy	Fz	Ft_ba	Ft_ah
	[kN]	[kN]	[kN]	[kN]	[kN]
bl1	17,0	3,0	2,4	-17,2	17,2
380ct1f1	129,3	22,8	20,5	-131,3	131,3
380ct1f2	129,3	22,8	20,5	-131,3	131,3
380ct1f3	129,3	22,8	20,5	-131,3	131,3
Post-isolato	0,0	0,0	5,0	0,0	
Post-isolato	0,0	0,0	3,5	0,0	
Post-isolato	0,0	0,0	5,0	0,0	
150ct2f1	64,7	11,4	11,8	-65,7	65,7
150ct2f2	64,7	11,4	11,8	-65,7	65,7
150ct2f3	64,7	11,4	11,8	-65,7	65,7

**Controle uplift SLS-wind**

Combinatie: Geleider	Fz_ba	Fz_ah
	[kN]	[kN]
SLS 4 bl1	0,0	0,0
380ct1f1	0,0	0,0
380ct1f2	0,0	0,0
380ct1f3	0,0	0,0
Post-isolato	0,0	
Post-isolato	0,0	
Post-isolato	0,0	
150ct2f1	0,0	0,0
150ct2f2	0,0	0,0
150ct2f3	0,0	0,0

Project: RLL-TLB380  
 Masttype: HA+6\_c - bouwphase  
 Mast: 1078

**ULS-fundatiebelasting combinatie 1 en 3 wind haaks op de lijn of bissectrice en EDS, vanuit geleiders**

Combinatie	Combination	$F_x$ [kN]	$F_y$ [kN]	$F_z$ [kN]	$M_x$ [kNm]	$M_y$ [kNm]	$M_z$ [kNm]
ULS 1a_90		-11	588	261	23872	-470	111
ULS 1a_0,9_0		12	245	186	9058	529	-143
ULS 1a_0,9_0,9_90		-12	565	122	24236	-528	125
ULS 3_0		4	364	351	12743	173	-46
SLS 7		0	211	208	7321	0	0

**ULS-fundatiebelasting combinatie 1 en 3 wind haaks op de lijn of bissectrice en EDS, totaal geleiders en mast**

Combinatie	$F_x$ [kN]	$F_y$ [kN]	$F_z$ [kN]	$M_x$ [kNm]	$M_y$ [kNm]	$M_z$ [kNm]
ULS 1a_90	-11	931	1610	34051	-470	111
ULS 1a_0,9_0,9_90	-12	907	1134	34415	-528	125
SLS 7	0	211	1332	7321	0	0

**Fundatiebelastingen, selectie belastingcombinaties op basis grootste waarde**

Combinatie	$F_x$ [kN]	$F_y$ [kN]	$F_z$ [kN]	$M_x$ [kNm]	$M_y$ [kNm]	$M_z$ [kNm]
ULS 1a_0,9_90	-11	931	1182	<b>34987</b>	-470	111
SPLS 3_90 Ah All Cts	-946	303	1525	10366	<b>-42466</b>	9697
SPLS 3_80 Ah All Cts	-934	307	1525	10502	-42216	<b>9758</b>
SPLS 1a_0,9_90 Ah All Cts	-844	445	1122	<b>15646</b>	<b>-37812</b>	8619

*Noot: grootste waarden kunnen in meerdere combinaties voorkomen, een combinatie is weergegeven.*

**Oplegreacties op fundering per randstijl**

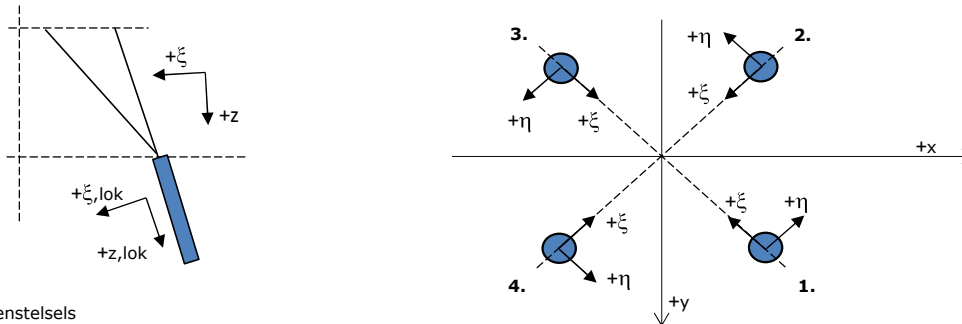

Assenstelsels

**Maximale drukbelasting**

Stijl	Combinatie	$R_x$ [kN]	$R_y$ [kN]	$R_z$ [kN]	$R_\eta$ [kN]	$R_\xi$ [kN]	$R_{\xi,lok}$ [kN]	$R_{z,lok}$ [kN]
1	SPLS 3_90 Ba All Cts	220	640	<b>2252</b>	-297	-608	-3	2332
2	SPLS 3_0 Ba All Cts	434	-199	<b>1678</b>	-166	-447	3	1737
3	ULS 8 Ba	-424	-167	<b>1601</b>	182	-418	12	1658
4	SPLS 1a_90 Ah All Cts	-249	625	<b>2262</b>	266	-618	-10	2343

**Maximale trekbelasting**

Stijl	Combinatie	$R_x$ [kN]	$R_y$ [kN]	$R_z$ [kN]	$R_\eta$ [kN]	$R_\xi$ [kN]	$R_{\xi,lok}$ [kN]	$R_{z,lok}$ [kN]
1	ULS 8 Ba	44	-350	<b>-921</b>	279	217	-31	-953
2	SPLS 1a_0,9_90 Ah All Cts	-422	181	<b>-1623</b>	171	426	-10	-1681
3	SPLS 1a_0,9_90 Ba All Cts	417	178	<b>-1602</b>	-169	421	-9	-1659
4	SPLS 3_0,9_0 Ba All Cts	-11	-362	<b>-1001</b>	-264	249	-20	-1036

**Maximale torsiebelasting (positief)**

Stijl	Combinatie	$R_x$ [kN]	$R_y$ [kN]	$R_z$ [kN]	$R_\eta$ [kN]	$R_\xi$ [kN]	$R_{\xi,lok}$ [kN]	$R_{z,lok}$ [kN]
1	SPLS 3_0,9_80 Ah All Cts	82	-352	-826	<b>307</b>	191	-31	-855
2	SPLS 3_0,9_80 Ah All Cts	-431	158	-1615	<b>193</b>	416	-18	-1672
3	SPLS 3_80 Ah All Cts	-409	-143	1510	<b>188</b>	-390	15	1564
4	SPLS 3_80 Ah All Cts	-218	644	2258	<b>302</b>	-609	-3	2338

**Maximale torsiebelasting (negatief)**

Index	Combinatie	$R_x$ [kN]	$R_y$ [kN]	$R_z$ [kN]	$R_\eta$ [kN]	$R_\xi$ [kN]	$R_{\xi,lok}$ [kN]	$R_{z,lok}$ [kN]
1	SPLS 3_100 Ba All Cts	217	640	2247	<b>-299</b>	-606	-2	2327
2	SPLS 3_100 Ba All Cts	406	-143	1499	<b>-186</b>	-388	15	1552
3	SPLS 3_0,9_100 Ba All Cts	426	156	-1593	<b>-191</b>	411	-17	-1650
4	SPLS 3_0,9_100 Ba All Cts	-81	-349	-821	<b>-304</b>	189	-31	-850

Project: RLL-TLB380  
 Masttype: HA+6\_c - bouwfase  
 Mast: 1078

#### Combinatie Ftrek+Fhor

Stijl	Combinatie	R <sub>x</sub> [kN]	R <sub>y</sub> [kN]	R <sub>z</sub> [kN]	R <sub>η</sub> [kN]	R <sub>ξ</sub> [kN]	R <sub>ξ,lok</sub> [kN]	R <sub>z,lok</sub> [kN]
1	ULS 8 Ba	44	-350	<b>-921</b>	<b>279</b>	217	-31	-953
2	SPLS 3_0,9_90 Ah All Cts	-431	160	<b>-1618</b>	<b>192</b>	418	-17	-1676
3	SPLS 3_0,9_90 Ba All Cts	426	158	<b>-1598</b>	<b>-190</b>	413	-16	-1655
4	SPLS 3_0,9_0 Ba All Cts	-11	-362	<b>-1001</b>	<b>-264</b>	249	-20	-1036

#### Permanente belasting

Stijl	Combinatie	R <sub>x</sub> [kN]	R <sub>y</sub> [kN]	R <sub>z</sub> [kN]	R <sub>η</sub> [kN]	R <sub>ξ</sub> [kN]	R <sub>ξ,lok</sub> [kN]	R <sub>z,lok</sub> [kN]
1	SLS 7	124	122	594	1	-174	-15	615
2	SLS 7	15	-17	72	1	-23	-3	75
3	SLS 7	-15	-17	72	-1	-23	-3	75
4	SLS 7	-124	122	594	-1	-174	-15	615

#### Omhullenden ongeacht stijl

Belasting	Combinatie	R <sub>x</sub> [kN]	R <sub>y</sub> [kN]	R <sub>z</sub> [kN]	R <sub>η</sub> [kN]	R <sub>ξ</sub> [kN]	R <sub>ξ,lok</sub> [kN]	R <sub>z,lok</sub> [kN]
Max. druk	SPLS 1a_90 Ah All Cts	-249	625	<b>2262</b>	266	-618	-10	2343
Max. trek	SPLS 1a_0,9_90 Ah All Cts	-422	181	<b>-1623</b>	171	426	-10	-1681
Max. pos. torsie	SPLS 3_0,9_80 Ah All Cts	82	-352	-826	<b>307</b>	191	-31	-855
Max. neg. torsie	SPLS 3_0,9_100 Ba All Cts	-81	-349	-821	<b>-304</b>	189	-31	-850
Comb. trek+torsie	SPLS 3_0,9_90 Ah All Cts	-431	160	<b>-1618</b>	<b>192</b>	418	-17	-1676

#### Maximale trekbelasting SLS

Stijl	Combinatie	R <sub>x</sub> [kN]	R <sub>y</sub> [kN]	R <sub>z</sub> [kN]	R <sub>η</sub> [kN]	R <sub>ξ</sub> [kN]	R <sub>ξ,lok</sub> [kN]	R <sub>z,lok</sub> [kN]
1	SPLS 3_0,9_100 Ah All Cts	72	-349	<b>-837</b>	298	196	-29	-867
2	SPLS 1a_0,9_100 Ah All Cts	-420	184	<b>-1615</b>	167	427	-7	-1673
3	SPLS 1a_0,9_100 Ba Ct2	191	141	<b>-883</b>	-36	235	-3	-914
4	SLS 1a_0	-51	45	<b>234</b>	-4	-68	-5	242

#### Maximale drukbelasting SLS

Stijl	Combinatie	R <sub>x</sub> [kN]	R <sub>y</sub> [kN]	R <sub>z</sub> [kN]	R <sub>η</sub> [kN]	R <sub>ξ</sub> [kN]	R <sub>ξ,lok</sub> [kN]	R <sub>z,lok</sub> [kN]
1	SPLS 1a_100 Ba Ct2	267	346	<b>1544</b>	-56	-434	-19	1599
2	SLS 1a_0	92	-90	<b>432</b>	-1	-129	-13	448
3	SPLS 3_100 Ah All Cts	-410	-149	<b>1522</b>	184	-396	13	1576
4	SPLS 3_80 Ah All Cts	-218	644	<b>2258</b>	302	-609	-3	2338

Project: RLL-TLB380  
Masttype: HA+6\_c - bouwfase  
Mast: 1078

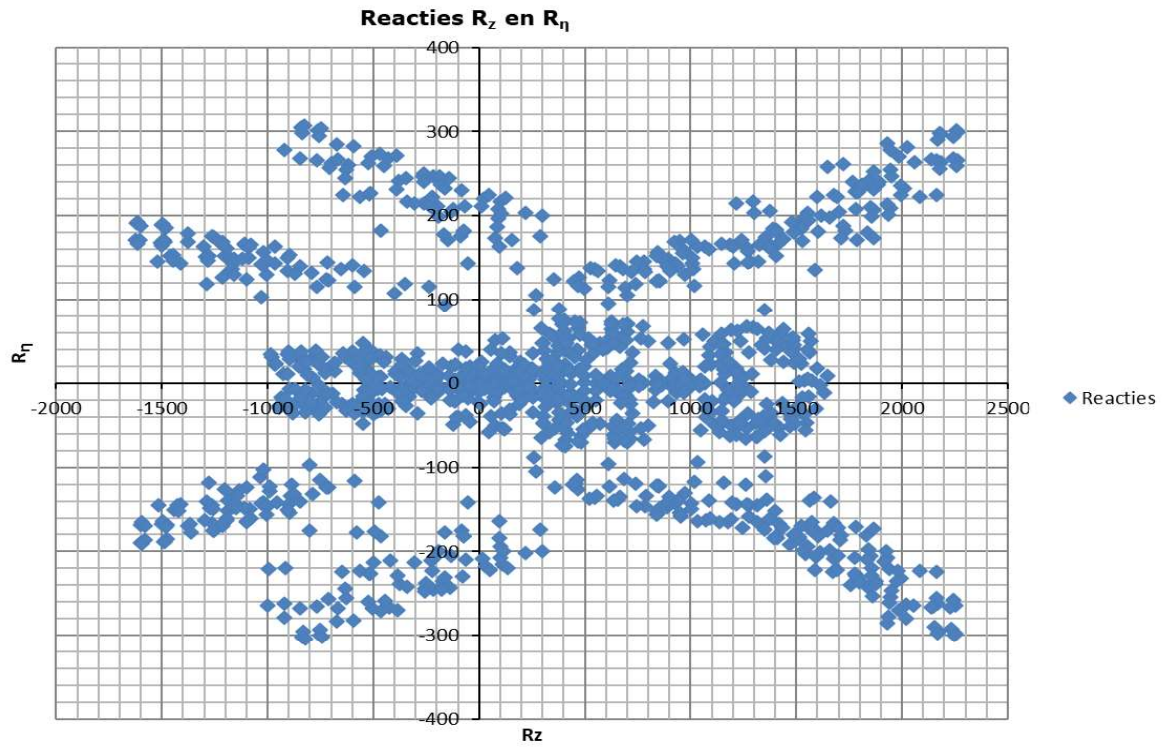

## Belastinggeval - afspannen

Date: 2021-05-10  
 Author: TBR  
 Version: 1.1

RLL-TLB  
 HA+6\_c (afspannen)

### Invoergegevens

#### **Hoogteafwijking mastbeeld naastgelegen masten en richtingsverandering t.o.v. Lijnrichting**

Circuits	Aanduiding	Nummer	Hoogteverschil		Richtingsverandering	
			Dh_back	Dh_ahead	Dy_back	Dy_ahead
Circuit 1	10	380ct1f1	0,0	-9,0 m	0,0	0,0 m
Circuit 1	11	380ct1f2	0,0	-9,0 m	0,0	0,0 m
Circuit 1	12	380ct1f3	0,0	-9,0 m	0,0	0,0 m
Circuit 2	13	380ct2f1	-54,0	0,0 m	0,0	0,0 m
Circuit 2	14	380ct2f2	-38,0	0,0 m	0,0	0,0 m
Circuit 2	15	380ct2f3	-28,5	0,0 m	0,0	0,0 m
Circuit 3	20	150ct3f1	0,0	-9,0 m	0,0	0,0 m
Circuit 3	21	150ct3f2	0,0	-9,0 m	0,0	0,0 m
Circuit 3	22	150ct3f3	0,0	-9,0 m	0,0	0,0 m
Circuit 4	23	150ct4f1	-54,0	0,0 m	0,0	0,0 m
Circuit 4	24	150ct4f2	-38,0	0,0 m	0,0	0,0 m
Circuit 4	25	150ct4f3	-28,5	0,0 m	0,0	0,0 m
Bliksemdraad 1	1	bl1	0,0	-9,0 m	0,0	0,0 m
Bliksemdraad 2	3	bl2	-59,1	0,0 m	0,0	0,0 m

### **Lijn- en mastgegevens**

		Back	Ahead
Ruling span $\sqrt{(SL3/SL)}$		82,5	400,0 m
Lijnhoek	$\beta$	180 °	
Rotatie mast t.o.v. bissectrice	$\theta$	-10 °	
Vaklengte		83	400 m
Hoogte onderkant mast t.o.v. maaiveld		0,5 m	
Beschouwde windrichtingen	a1	0 °	
Windrichtingen volgens:	a2	45 °	
<i>Geleiderbelastingen</i>	a3	90 °	
	a4	135 °	
	a5	100 °	
	a6	100 °	

*Windrichtingen gelden t.o.v. hoofdrichting mastconstructie, niet t.o.v. bissectrice.*

In onderstaande tabel zijn de optredende belastingen weergegeven, voor deze situatie geldt:

- belasting op geleider1, 10 t/m 12 en 20 t/m 22 zijn permanent aanwezig
- van de belasting op de overige geleiders is er telkens één aanwezig per belastingcombinatie

### Uitvoer geleiderbelastingen

Belastingcombi	nummer	Fxtotaal	Fytotaal	Fztotaal	Ftrekahead	Ftrekback
<b>ULS 6b_90</b>	10	<b>156,3</b>	<b>32,5</b>	<b>24,7</b>	159,5	0,0
	11	<b>155,7</b>	<b>32,0</b>	<b>24,7</b>	158,9	0,0
	12	<b>155,1</b>	<b>31,4</b>	<b>24,7</b>	158,2	0,0
	1	<b>21,2</b>	<b>4,7</b>	<b>2,9</b>	21,7	0,0
	20	<b>78,1</b>	<b>16,3</b>	<b>13,0</b>	79,8	0,0
	21	<b>77,8</b>	<b>16,1</b>	<b>12,9</b>	79,5	0,0
	22	<b>77,5</b>	<b>15,8</b>	<b>12,9</b>	79,1	0,0
	3	<b>-19,4</b>	<b>-3,2</b>	<b>14,7</b>	0,0	-19,7
	13	<b>-147,7</b>	<b>-24,9</b>	<b>105,2</b>	0,0	-149,8
	14	<b>-147,6</b>	<b>-24,9</b>	<b>76,2</b>	0,0	-149,7
	15	<b>-147,5</b>	<b>-24,9</b>	<b>58,9</b>	0,0	-149,6
	23	<b>-73,9</b>	<b>-12,3</b>	<b>53,2</b>	0,0	-74,9
	24	<b>-73,8</b>	<b>-12,4</b>	<b>38,7</b>	0,0	-74,9
	25	<b>-73,8</b>	<b>-12,4</b>	<b>30,0</b>	0,0	-74,8



## **APPENDIX B**

---

### **Resultaten PLS-TOWER**

Deze Appendix bevat de resultaten uit PLS-TOWER voor de verschillende masttypen. De samenstelling van de bovenstukken zijn voor alle masttypen gelijk. De resultaten van het bovenstuk zijn dan ook alleen opgenomen van het maatgevende masttype HA+6/c. De resultaten van het onderstuk zijn voor alle masten opgenomen.

Resultaten opgenomen voor:

- Masttype HA+0/c
- Masttype HA+3/c
- Masttype HA+6/c

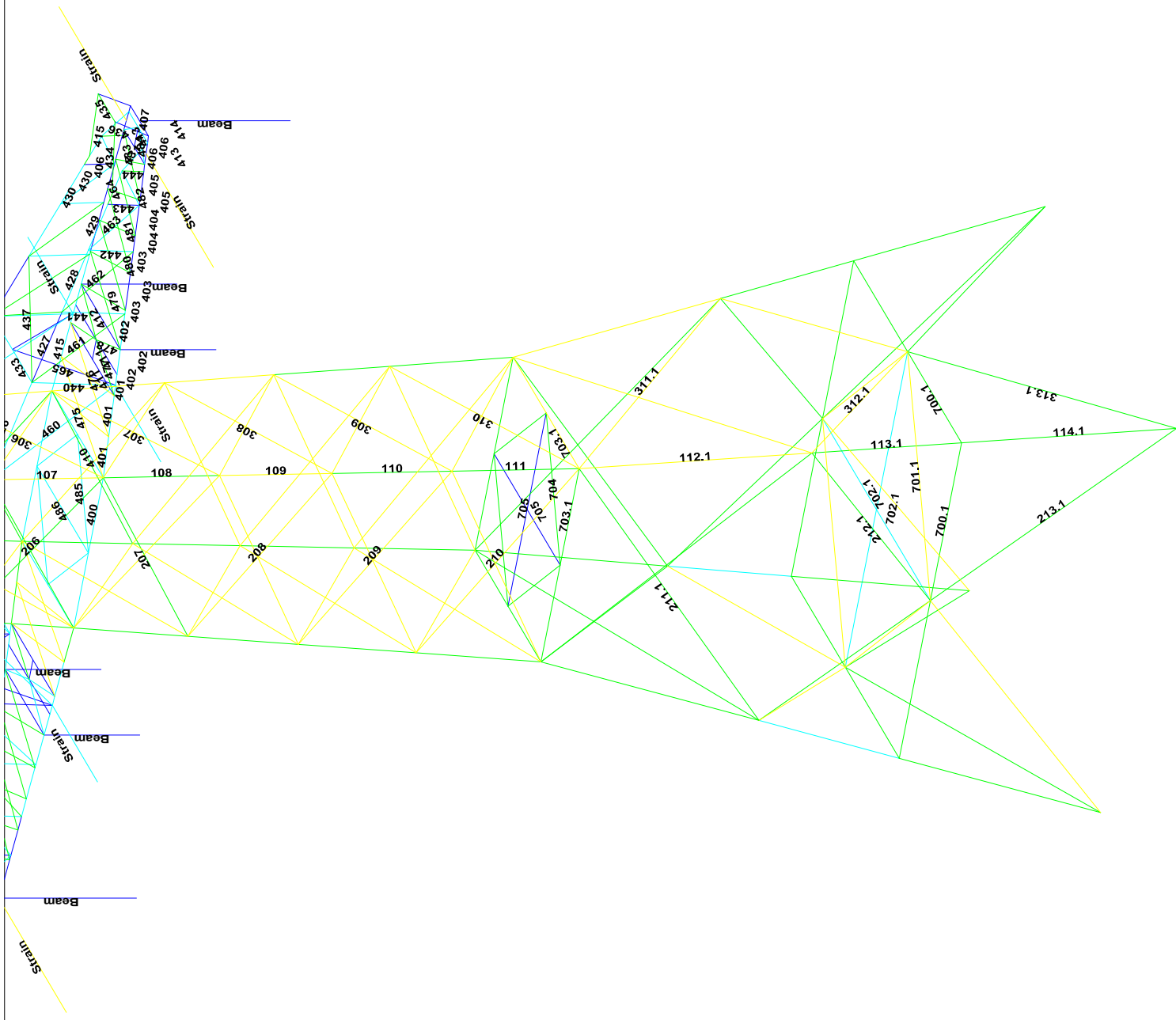



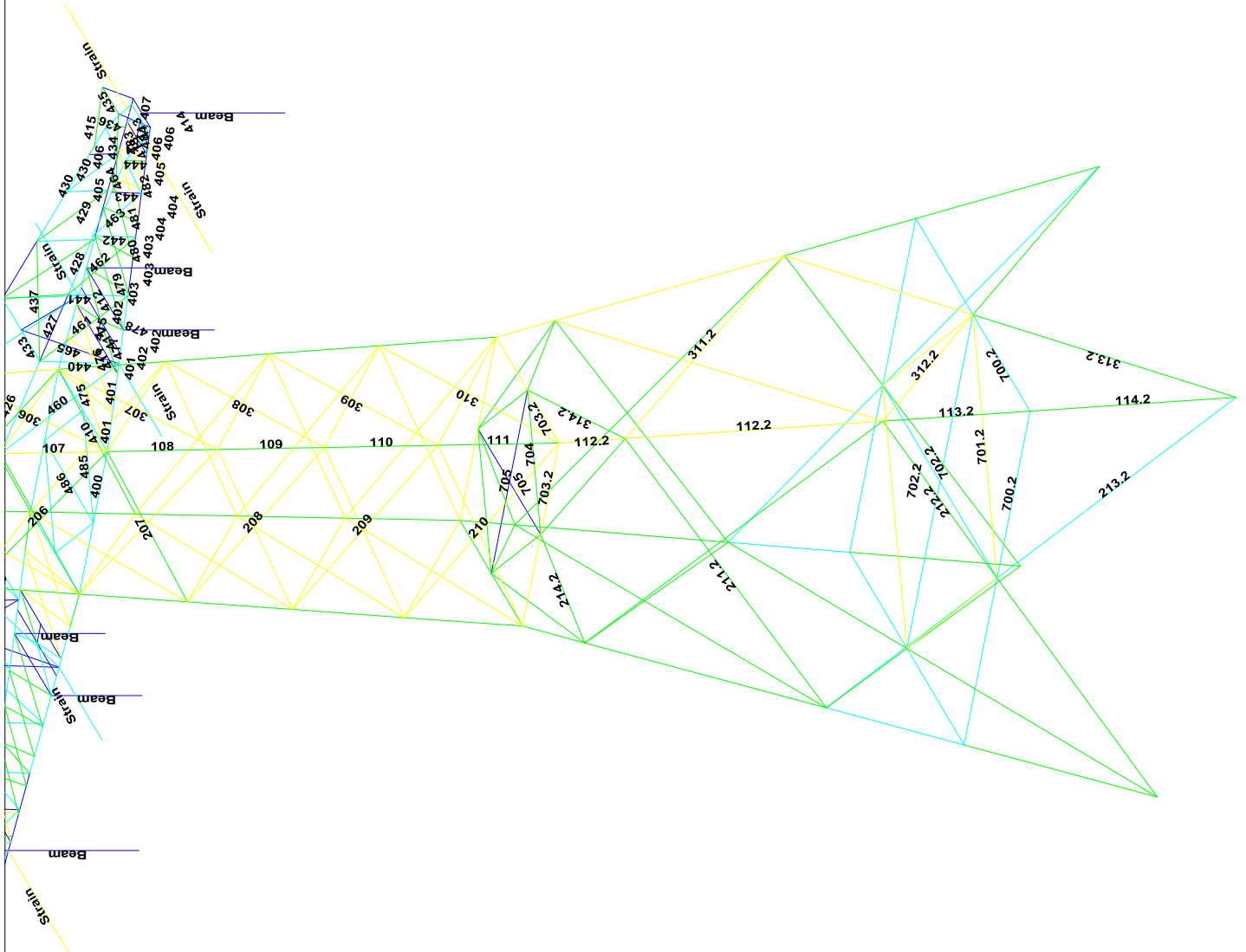

% Usage Legend	
0% <= % < 25	Blue
25 <= % < 50	Green
50 <= % < 75	Yellow
75 <= % < 100	Red
100 <= %	Black





Assessment of angle groups - Lower structure

Date 15-7-2021  
 Author MRE  
 Version 2.0

RLI\_TBG  
 HA4-3/C

Group Label	Description	Type	Profile	Steel (Q235)	Flange	Web	h <sub>0</sub>	h <sub>1</sub>	C <sub>1</sub>	C <sub>2</sub>	h <sub>1</sub>	h <sub>2</sub>	h <sub>3</sub>	h <sub>4</sub>	h <sub>5</sub>	h <sub>6</sub>	h <sub>7</sub>	h <sub>8</sub>	h <sub>9</sub>	h <sub>10</sub>	h <sub>11</sub>	h <sub>12</sub>	h <sub>13</sub>	h <sub>14</sub>	h <sub>15</sub>	h <sub>16</sub>	h <sub>17</sub>	h <sub>18</sub>	h <sub>19</sub>	h <sub>20</sub>	h <sub>21</sub>	h <sub>22</sub>	h <sub>23</sub>	h <sub>24</sub>	h <sub>25</sub>	h <sub>26</sub>	h <sub>27</sub>	h <sub>28</sub>	h <sub>29</sub>	h <sub>30</sub>	h <sub>31</sub>	h <sub>32</sub>	h <sub>33</sub>	h <sub>34</sub>	h <sub>35</sub>	h <sub>36</sub>	h <sub>37</sub>	h <sub>38</sub>	h <sub>39</sub>	h <sub>40</sub>	h <sub>41</sub>	h <sub>42</sub>	h <sub>43</sub>	h <sub>44</sub>	h <sub>45</sub>	h <sub>46</sub>	h <sub>47</sub>	h <sub>48</sub>	h <sub>49</sub>	h <sub>50</sub>	h <sub>51</sub>	h <sub>52</sub>	h <sub>53</sub>	h <sub>54</sub>	h <sub>55</sub>	h <sub>56</sub>	h <sub>57</sub>	h <sub>58</sub>	h <sub>59</sub>	h <sub>60</sub>	h <sub>61</sub>	h <sub>62</sub>	h <sub>63</sub>	h <sub>64</sub>	h <sub>65</sub>	h <sub>66</sub>	h <sub>67</sub>	h <sub>68</sub>	h <sub>69</sub>	h <sub>70</sub>	h <sub>71</sub>	h <sub>72</sub>	h <sub>73</sub>	h <sub>74</sub>	h <sub>75</sub>	h <sub>76</sub>	h <sub>77</sub>	h <sub>78</sub>	h <sub>79</sub>	h <sub>80</sub>	h <sub>81</sub>	h <sub>82</sub>	h <sub>83</sub>	h <sub>84</sub>	h <sub>85</sub>	h <sub>86</sub>	h <sub>87</sub>	h <sub>88</sub>	h <sub>89</sub>	h <sub>90</sub>	h <sub>91</sub>	h <sub>92</sub>	h <sub>93</sub>	h <sub>94</sub>	h <sub>95</sub>	h <sub>96</sub>	h <sub>97</sub>	h <sub>98</sub>	h <sub>99</sub>	h <sub>100</sub>	h <sub>101</sub>	h <sub>102</sub>	h <sub>103</sub>	h <sub>104</sub>	h <sub>105</sub>	h <sub>106</sub>	h <sub>107</sub>	h <sub>108</sub>	h <sub>109</sub>	h <sub>110</sub>	h <sub>111</sub>	h <sub>112</sub>	h <sub>113</sub>	h <sub>114</sub>	h <sub>115</sub>	h <sub>116</sub>	h <sub>117</sub>	h <sub>118</sub>	h <sub>119</sub>	h <sub>120</sub>	h <sub>121</sub>	h <sub>122</sub>	h <sub>123</sub>	h <sub>124</sub>	h <sub>125</sub>	h <sub>126</sub>	h <sub>127</sub>	h <sub>128</sub>	h <sub>129</sub>	h <sub>130</sub>	h <sub>131</sub>	h <sub>132</sub>	h <sub>133</sub>	h <sub>134</sub>	h <sub>135</sub>	h <sub>136</sub>	h <sub>137</sub>	h <sub>138</sub>	h <sub>139</sub>	h <sub>140</sub>	h <sub>141</sub>	h <sub>142</sub>	h <sub>143</sub>	h <sub>144</sub>	h <sub>145</sub>	h <sub>146</sub>	h <sub>147</sub>	h <sub>148</sub>	h <sub>149</sub>	h <sub>150</sub>	h <sub>151</sub>	h <sub>152</sub>	h <sub>153</sub>	h <sub>154</sub>	h <sub>155</sub>	h <sub>156</sub>	h <sub>157</sub>	h <sub>158</sub>	h <sub>159</sub>	h <sub>160</sub>	h <sub>161</sub>	h <sub>162</sub>	h <sub>163</sub>	h <sub>164</sub>	h <sub>165</sub>	h <sub>166</sub>	h <sub>167</sub>	h <sub>168</sub>	h <sub>169</sub>	h <sub>170</sub>	h <sub>171</sub>	h <sub>172</sub>	h <sub>173</sub>	h <sub>174</sub>	h <sub>175</sub>	h <sub>176</sub>	h <sub>177</sub>	h <sub>178</sub>	h <sub>179</sub>	h <sub>180</sub>	h <sub>181</sub>	h <sub>182</sub>	h <sub>183</sub>	h <sub>184</sub>	h <sub>185</sub>	h <sub>186</sub>	h <sub>187</sub>	h <sub>188</sub>	h <sub>189</sub>	h <sub>190</sub>	h <sub>191</sub>	h <sub>192</sub>	h <sub>193</sub>	h <sub>194</sub>	h <sub>195</sub>	h <sub>196</sub>	h <sub>197</sub>	h <sub>198</sub>	h <sub>199</sub>	h <sub>200</sub>	h <sub>201</sub>	h <sub>202</sub>	h <sub>203</sub>	h <sub>204</sub>	h <sub>205</sub>	h <sub>206</sub>	h <sub>207</sub>	h <sub>208</sub>	h <sub>209</sub>	h <sub>210</sub>	h <sub>211</sub>	h <sub>212</sub>	h <sub>213</sub>	h <sub>214</sub>	h <sub>215</sub>	h <sub>216</sub>	h <sub>217</sub>	h <sub>218</sub>	h <sub>219</sub>	h <sub>220</sub>	h <sub>221</sub>	h <sub>222</sub>	h <sub>223</sub>	h <sub>224</sub>	h <sub>225</sub>	h <sub>226</sub>	h <sub>227</sub>	h <sub>228</sub>	h <sub>229</sub>	h <sub>230</sub>	h <sub>231</sub>	h <sub>232</sub>	h <sub>233</sub>	h <sub>234</sub>	h <sub>235</sub>	h <sub>236</sub>	h <sub>237</sub>	h <sub>238</sub>	h <sub>239</sub>	h <sub>240</sub>	h <sub>241</sub>	h <sub>242</sub>	h <sub>243</sub>	h <sub>244</sub>	h <sub>245</sub>	h <sub>246</sub>	h <sub>247</sub>	h <sub>248</sub>	h <sub>249</sub>	h <sub>250</sub>	h <sub>251</sub>	h <sub>252</sub>	h <sub>253</sub>	h <sub>254</sub>	h <sub>255</sub>	h <sub>256</sub>	h <sub>257</sub>	h <sub>258</sub>	h <sub>259</sub>	h <sub>260</sub>	h <sub>261</sub>	h <sub>262</sub>	h <sub>263</sub>	h <sub>264</sub>	h <sub>265</sub>	h <sub>266</sub>	h <sub>267</sub>	h <sub>268</sub>	h <sub>269</sub>	h <sub>270</sub>	h <sub>271</sub>	h <sub>272</sub>	h <sub>273</sub>	h <sub>274</sub>	h <sub>275</sub>	h <sub>276</sub>	h <sub>277</sub>	h <sub>278</sub>	h <sub>279</sub>	h <sub>280</sub>	h <sub>281</sub>	h <sub>282</sub>	h <sub>283</sub>	h <sub>284</sub>	h <sub>285</sub>	h <sub>286</sub>	h <sub>287</sub>	h <sub>288</sub>	h <sub>289</sub>	h <sub>290</sub>	h <sub>291</sub>	h <sub>292</sub>	h <sub>293</sub>	h <sub>294</sub>	h <sub>295</sub>	h <sub>296</sub>	h <sub>297</sub>	h <sub>298</sub>	h <sub>299</sub>	h <sub>300</sub>	h <sub>301</sub>	h <sub>302</sub>	h <sub>303</sub>	h <sub>304</sub>	h <sub>305</sub>	h <sub>306</sub>	h <sub>307</sub>	h <sub>308</sub>	h <sub>309</sub>	h <sub>310</sub>	h <sub>311</sub>	h <sub>312</sub>	h <sub>313</sub>	h <sub>314</sub>	h <sub>315</sub>	h <sub>316</sub>	h <sub>317</sub>	h <sub>318</sub>	h <sub>319</sub>	h <sub>320</sub>	h <sub>321</sub>	h <sub>322</sub>	h <sub>323</sub>	h <sub>324</sub>	h <sub>325</sub>	h <sub>326</sub>	h <sub>327</sub>	h <sub>328</sub>	h <sub>329</sub>	h <sub>330</sub>	h <sub>331</sub>	h <sub>332</sub>	h <sub>333</sub>	h <sub>334</sub>	h <sub>335</sub>	h <sub>336</sub>	h <sub>337</sub>	h <sub>338</sub>	h <sub>339</sub>	h <sub>340</sub>	h <sub>341</sub>	h <sub>342</sub>	h <sub>343</sub>	h <sub>344</sub>	h <sub>345</sub>	h <sub>346</sub>	h <sub>347</sub>	h <sub>348</sub>	h <sub>349</sub>	h <sub>350</sub>	h <sub>351</sub>	h <sub>352</sub>	h <sub>353</sub>	h <sub>354</sub>	h <sub>355</sub>	h <sub>356</sub>	h <sub>357</sub>	h <sub>358</sub>	h <sub>359</sub>	h <sub>360</sub>	h <sub>361</sub>	h <sub>362</sub>	h <sub>363</sub>	h <sub>364</sub>	h <sub>365</sub>	h <sub>366</sub>	h <sub>367</sub>	h <sub>368</sub>	h <sub>369</sub>	h <sub>370</sub>	h <sub>371</sub>	h <sub>372</sub>	h <sub>373</sub>	h <sub>374</sub>	h <sub>375</sub>	h <sub>376</sub>	h <sub>377</sub>	h <sub>378</sub>	h <sub>379</sub>	h <sub>380</sub>	h <sub>381</sub>	h <sub>382</sub>	h <sub>383</sub>	h <sub>384</sub>	h <sub>385</sub>	h <sub>386</sub>	h <sub>387</sub>	h <sub>388</sub>	h <sub>389</sub>	h <sub>390</sub>	h <sub>391</sub>	h <sub>392</sub>	h <sub>393</sub>	h <sub>394</sub>	h <sub>395</sub>	h <sub>396</sub>	h <sub>397</sub>	h <sub>398</sub>	h <sub>399</sub>	h <sub>400</sub>	h <sub>401</sub>	h <sub>402</sub>	h <sub>403</sub>	h <sub>404</sub>	h <sub>405</sub>	h <sub>406</sub>	h <sub>407</sub>	h <sub>408</sub>	h <sub>409</sub>	h <sub>410</sub>	h <sub>411</sub>	h <sub>412</sub>	h <sub>413</sub>	h <sub>414</sub>	h <sub>415</sub>	h <sub>416</sub>	h <sub>417</sub>	h <sub>418</sub>	h <sub>419</sub>	h <sub>420</sub>	h <sub>421</sub>	h <sub>422</sub>	h <sub>423</sub>	h <sub>424</sub>	h <sub>425</sub>	h <sub>426</sub>	h <sub>427</sub>	h <sub>428</sub>	h <sub>429</sub>	h <sub>430</sub>	h <sub>431</sub>	h <sub>432</sub>	h <sub>433</sub>	h <sub>434</sub>	h <sub>435</sub>	h <sub>436</sub>	h <sub>437</sub>	h <sub>438</sub>	h <sub>439</sub>	h <sub>440</sub>	h <sub>441</sub>	h <sub>442</sub>	h <sub>443</sub>	h <sub>444</sub>	h <sub>445</sub>	h <sub>446</sub>	h <sub>447</sub>	h <sub>448</sub>	h <sub>449</sub>	h <sub>450</sub>	h <sub>451</sub>	h <sub>452</sub>	h <sub>453</sub>	h <sub>454</sub>	h <sub>455</sub>	h <sub>456</sub>	h <sub>457</sub>	h <sub>458</sub>	h <sub>459</sub>	h <sub>460</sub>	h <sub>461</sub>	h <sub>462</sub>	h <sub>463</sub>	h <sub>464</sub>	h <sub>465</sub>	h <sub>466</sub>	h <sub>467</sub>	h <sub>468</sub>	h <sub>469</sub>	h <sub>470</sub>	h <sub>471</sub>	h <sub>472</sub>	h <sub>473</sub>	h <sub>474</sub>	h <sub>475</sub>	h <sub>476</sub>	h <sub>477</sub>	h <sub>478</sub>	h <sub>479</sub>	h <sub>480</sub>	h <sub>481</sub>	h <sub>482</sub>	h <sub>483</sub>	h <sub>484</sub>	h <sub>485</sub>	h <sub>486</sub>	h <sub>487</sub>	h <sub>488</sub>	h <sub>489</sub>	h <sub>490</sub>	h <sub>491</sub>	h <sub>492</sub>	h <sub>493</sub>	h <sub>494</sub>	h <sub>495</sub>	h <sub>496</sub>	h <sub>497</sub>	h <sub>498</sub>	h <sub>499</sub>	h <sub>500</sub>	h <sub>501</sub>	h <sub>502</sub>	h <sub>503</sub>	h <sub>504</sub>	h <sub>505</sub>	h <sub>506</sub>	h <sub>507</sub>	h <sub>508</sub>	h <sub>509</sub>	h <sub>510</sub>	h <sub>511</sub>	h <sub>512</sub>	h <sub>513</sub>	h <sub>514</sub>	h <sub>515</sub>	h <sub>516</sub>	h <sub>517</sub>	h <sub>518</sub>	h <sub>519</sub>	h <sub>520</sub>	h <sub>521</sub>	h <sub>522</sub>	h <sub>523</sub>	h <sub>524</sub>	h <sub>525</sub>	h <sub>526</sub>	h <sub>527</sub>	h <sub>528</sub>	h <sub>529</sub>	h <sub>530</sub>	h <sub>531</sub>	h <sub>532</sub>	h <sub>533</sub>	h <sub>534</sub>	h <sub>535</sub>	h <sub>536</sub>	h <sub>537</sub>	h <sub>538</sub>	h <sub>539</sub>	h <sub>540</sub>	h <sub>541</sub>	h <sub>542</sub>	h <sub>543</sub>	h <sub>544</sub>	h <sub>545</sub>	h <sub>546</sub>	h <sub>547</sub>	h <sub>548</sub>	h <sub>549</sub>	h <sub>550</sub>	h <sub>551</sub>	h <sub>552</sub>	h <sub>553</sub>	h <sub>554</sub>	h <sub>555</sub>	h <sub>556</sub>	h <sub>557</sub>	h <sub>558</sub>	h <sub>559</sub>	h <sub>560</sub>	h <sub>561</sub>	h <sub>562</sub>	h <sub>563</sub>	h <sub>564</sub>	h <sub>565</sub>	h <sub>566</sub>	h <sub>567</sub>	h <sub>568</sub>	h <sub>569</sub>	h <sub>570</sub>	h <sub>571</sub>	h <sub>572</sub>	h <sub>573</sub>	h <sub>574</sub>	h <sub>575</sub>	h <sub>576</sub>	h <sub>577</sub>	h <sub>578</sub>	h <sub>579</sub>	h <sub>580</sub>	h <sub>581</sub>	h <sub>582</sub>	h <sub>583</sub>	h <sub>584</sub>	h <sub>585</sub>	h <sub>586</sub>	h <sub>587</sub>	h <sub>588</sub>	h <sub>589</sub>	h <sub>590</sub>	h <sub>591</sub>	h <sub>592</sub>	h <sub>593</sub>	h <sub>594</sub>	h <sub>595</sub>	h <sub>596</sub>	h <sub>597</sub>	h <sub>598</sub>	h <sub>599</sub>	h <sub>600</sub>	h <sub>601</sub>	h <sub>602</sub>	h <sub>603</sub>	h <sub>604</sub>	h <sub>605</sub>	h <sub>606</sub>	h <sub>607</sub>	h <sub>608</sub>	h <sub>609</sub>	h <sub>610</sub>	h <sub>611</sub>	h <sub>612</sub>	h <sub>613</sub>	h <sub>614</sub>	h <sub>615</sub>	h <sub>616</sub>	h <sub>617</sub>	h <sub>618</sub>	h <sub>619</sub>	h <sub>620</sub>	h <sub>621</sub>	h <sub>622</sub>	h <sub>623</sub>	h <sub>624</sub>	h <sub>625</sub>	h <sub>626</sub>	h <sub>627</sub>	h <sub>628</sub>	h <sub>629</sub>	h <sub>630</sub>	h <sub>631</sub>	h <sub>632</sub>	h <sub>633</sub>	h <sub>634</sub>	h <sub>635</sub>	h <sub>636</sub>	h <sub>637</sub>	h <sub>638</sub>	h <sub>639</sub>	h <sub>640</sub>	h <sub>641</sub>	h <sub>642</sub>	h <sub>643</sub>	h <sub>644</sub>	h <sub>645</sub>	h <sub>646</sub>	h <sub>647</sub>	h <sub>648</sub>	h <sub>649</sub>	h <sub>650</sub>	h <sub>651</sub>	h <sub>652</sub>	h <sub>653</sub>	h <sub>654</sub>	h <sub>655</sub>	h <sub>656</sub>	h <sub>657</sub>	h <sub>658</sub>	h <sub>659</sub>	h <sub>660</sub>	h <sub>661</sub>	h <sub>662</sub>	h <sub>663</sub>	h <sub>664</sub>	h <sub>665</sub>	h <sub>666</sub>	h <sub>667</sub>	h <sub>668</sub>	h <sub>669</sub>	h <sub>670</sub>	h <sub>671</sub>	h <sub>672</sub>	h <sub>673</sub>	h <sub>674</sub>	h <sub>675</sub>	h <sub>676</sub>	h <sub>677</sub>	h <sub>678</sub>	h <sub>679</sub>	h <sub>680</sub>	h <sub>681</sub>	h <sub>682</sub>	h <sub>683</sub>	h <sub>684</sub>	h <sub>685</sub>	h <sub>686</sub>	h <sub>687</sub>	h <sub>688</sub>	h <sub>689</sub>	h <sub>690</sub>	h <sub>691</sub>	h <sub>692</sub>	h <sub>693</sub>	h <sub>694</sub>	h <sub>695</sub>	h <sub>696</sub>	h <sub>697</sub>	h <sub>698</sub>	h <sub>699</sub>	h <sub>700</sub>	h <sub>701</sub>	h <sub>702</sub>	h <sub>703</sub>	h <sub>704</sub>	h <sub>705</sub>	h <sub>706</sub>	h <sub>707</sub>	h <sub>708</sub>	h <sub>709</sub>	h <sub>710</sub>	h <sub>711</sub>	h <sub>712</sub>	h <sub>713</sub>	h <sub>714</sub>	h <sub>715</sub>	h <sub>716</sub>	h <sub>717</sub>	h <sub>718</sub>	h <sub>719</sub>	h <sub>720</sub>	h <sub>721</sub>	h <sub>722</sub>	h <sub>723</sub>	h <sub>724</sub>	h <sub>725</sub>	h <sub>726</sub>	h <sub>727</sub>	h <sub>728</sub>	h <sub>729</sub>	h <sub>730</sub>	h <sub>731</sub>	h <sub>732</sub>	h <sub>733</sub>	h <sub>734</sub>	h <sub>735</sub>	h <sub>736</sub>	h <sub>737</sub>	h <sub>738</sub>	h <sub>739</sub>	h <sub>740</sub>	h <sub>741</sub>	h <sub>742</sub>	h <sub>743</sub>	h <sub>744</sub>	h <sub>745</sub>	h <sub>746</sub>	h <sub>747</sub>	h <sub>748</sub>	h <sub>749</sub>	h <sub>750</sub>	h <sub>751</sub>	h <sub>752</sub>	h <sub>753</sub>	h <sub>754</sub>	h <sub>755</sub>	h <sub>756</sub>	h <sub>757</sub>	h <sub>758</sub>	h <sub>759</sub>	h <sub>760</sub>	h <sub>761</sub>	h <sub>762</sub>	h <sub>763</sub>	h <sub>764</sub>	h <sub>765</sub>	h <sub>766</sub>	h <sub>767</sub>	h <sub>768</sub>	h <sub>769</sub>	h <sub>770</sub>	h <sub>771</sub>	h <sub>772</sub>	h <sub>773</sub>	h <sub>774</sub>	h <sub>775</sub>	h <sub>776</sub>	h <sub>777</sub>	h <sub>778</sub>	h <sub>779</sub>	h <sub>780</sub>	h <sub>781</sub>	h <sub>782</sub>	h <sub>783</sub>	h <sub>784</sub>	h <sub>785</sub>	h <sub>786</sub>	h <sub>787</sub>	h <sub>788</sub>	h <sub>789</sub>	h <sub>790</sub>	h <sub>791</sub>	h <sub>792</sub>	h <sub>793</sub>	h <sub>794</sub>	h <sub>795</sub>	h <sub>796</sub>	h <sub>797</sub>	h <sub>798</sub>	h <sub>799</sub>	h <sub>800</sub>	h <sub>801</sub>	h <sub>802</sub>	h <sub>803</sub>	h <sub>804</sub>	h <sub>805</sub>	h <sub>806</sub>	h <sub>807</sub>	h <sub>808</sub>	h <sub>809</sub>	h <sub>810</sub> </
-------------	-------------	------	---------	--------------	--------	-----	----------------	----------------	----------------	----------------	----------------	----------------	----------------	----------------	----------------	----------------	----------------	----------------	----------------	-----------------	-----------------	-----------------	-----------------	-----------------	-----------------	-----------------	-----------------	-----------------	-----------------	-----------------	-----------------	-----------------	-----------------	-----------------	-----------------	-----------------	-----------------	-----------------	-----------------	-----------------	-----------------	-----------------	-----------------	-----------------	-----------------	-----------------	-----------------	-----------------	-----------------	-----------------	-----------------	-----------------	-----------------	-----------------	-----------------	-----------------	-----------------	-----------------	-----------------	-----------------	-----------------	-----------------	-----------------	-----------------	-----------------	-----------------	-----------------	-----------------	-----------------	-----------------	-----------------	-----------------	-----------------	-----------------	-----------------	-----------------	-----------------	-----------------	-----------------	-----------------	-----------------	-----------------	-----------------	-----------------	-----------------	-----------------	-----------------	-----------------	-----------------	-----------------	-----------------	-----------------	-----------------	-----------------	-----------------	-----------------	-----------------	-----------------	-----------------	-----------------	-----------------	-----------------	-----------------	-----------------	-----------------	-----------------	-----------------	-----------------	-----------------	------------------	------------------	------------------	------------------	------------------	------------------	------------------	------------------	------------------	------------------	------------------	------------------	------------------	------------------	------------------	------------------	------------------	------------------	------------------	------------------	------------------	------------------	------------------	------------------	------------------	------------------	------------------	------------------	------------------	------------------	------------------	------------------	------------------	------------------	------------------	------------------	------------------	------------------	------------------	------------------	------------------	------------------	------------------	------------------	------------------	------------------	------------------	------------------	------------------	------------------	------------------	------------------	------------------	------------------	------------------	------------------	------------------	------------------	------------------	------------------	------------------	------------------	------------------	------------------	------------------	------------------	------------------	------------------	------------------	------------------	------------------	------------------	------------------	------------------	------------------	------------------	------------------	------------------	------------------	------------------	------------------	------------------	------------------	------------------	------------------	------------------	------------------	------------------	------------------	------------------	------------------	------------------	------------------	------------------	------------------	------------------	------------------	------------------	------------------	------------------	------------------	------------------	------------------	------------------	------------------	------------------	------------------	------------------	------------------	------------------	------------------	------------------	------------------	------------------	------------------	------------------	------------------	------------------	------------------	------------------	------------------	------------------	------------------	------------------	------------------	------------------	------------------	------------------	------------------	------------------	------------------	------------------	------------------	------------------	------------------	------------------	------------------	------------------	------------------	------------------	------------------	------------------	------------------	------------------	------------------	------------------	------------------	------------------	------------------	------------------	------------------	------------------	------------------	------------------	------------------	------------------	------------------	------------------	------------------	------------------	------------------	------------------	------------------	------------------	------------------	------------------	------------------	------------------	------------------	------------------	------------------	------------------	------------------	------------------	------------------	------------------	------------------	------------------	------------------	------------------	------------------	------------------	------------------	------------------	------------------	------------------	------------------	------------------	------------------	------------------	------------------	------------------	------------------	------------------	------------------	------------------	------------------	------------------	------------------	------------------	------------------	------------------	------------------	------------------	------------------	------------------	------------------	------------------	------------------	------------------	------------------	------------------	------------------	------------------	------------------	------------------	------------------	------------------	------------------	------------------	------------------	------------------	------------------	------------------	------------------	------------------	------------------	------------------	------------------	------------------	------------------	------------------	------------------	------------------	------------------	------------------	------------------	------------------	------------------	------------------	------------------	------------------	------------------	------------------	------------------	------------------	------------------	------------------	------------------	------------------	------------------	------------------	------------------	------------------	------------------	------------------	------------------	------------------	------------------	------------------	------------------	------------------	------------------	------------------	------------------	------------------	------------------	------------------	------------------	------------------	------------------	------------------	------------------	------------------	------------------	------------------	------------------	------------------	------------------	------------------	------------------	------------------	------------------	------------------	------------------	------------------	------------------	------------------	------------------	------------------	------------------	------------------	------------------	------------------	------------------	------------------	------------------	------------------	------------------	------------------	------------------	------------------	------------------	------------------	------------------	------------------	------------------	------------------	------------------	------------------	------------------	------------------	------------------	------------------	------------------	------------------	------------------	------------------	------------------	------------------	------------------	------------------	------------------	------------------	------------------	------------------	------------------	------------------	------------------	------------------	------------------	------------------	------------------	------------------	------------------	------------------	------------------	------------------	------------------	------------------	------------------	------------------	------------------	------------------	------------------	------------------	------------------	------------------	------------------	------------------	------------------	------------------	------------------	------------------	------------------	------------------	------------------	------------------	------------------	------------------	------------------	------------------	------------------	------------------	------------------	------------------	------------------	------------------	------------------	------------------	------------------	------------------	------------------	------------------	------------------	------------------	------------------	------------------	------------------	------------------	------------------	------------------	------------------	------------------	------------------	------------------	------------------	------------------	------------------	------------------	------------------	------------------	------------------	------------------	------------------	------------------	------------------	------------------	------------------	------------------	------------------	------------------	------------------	------------------	------------------	------------------	------------------	------------------	------------------	------------------	------------------	------------------	------------------	------------------	------------------	------------------	------------------	------------------	------------------	------------------	------------------	------------------	------------------	------------------	------------------	------------------	------------------	------------------	------------------	------------------	------------------	------------------	------------------	------------------	------------------	------------------	------------------	------------------	------------------	------------------	------------------	------------------	------------------	------------------	------------------	------------------	------------------	------------------	------------------	------------------	------------------	------------------	------------------	------------------	------------------	------------------	------------------	------------------	------------------	------------------	------------------	------------------	------------------	------------------	------------------	------------------	------------------	------------------	------------------	------------------	------------------	------------------	------------------	------------------	------------------	------------------	------------------	------------------	------------------	------------------	------------------	------------------	------------------	------------------	------------------	------------------	------------------	------------------	------------------	------------------	------------------	------------------	------------------	------------------	------------------	------------------	------------------	------------------	------------------	------------------	------------------	------------------	------------------	------------------	------------------	------------------	------------------	------------------	------------------	------------------	------------------	------------------	------------------	------------------	------------------	------------------	------------------	------------------	------------------	------------------	------------------	------------------	------------------	------------------	------------------	------------------	------------------	------------------	------------------	------------------	------------------	------------------	------------------	------------------	------------------	------------------	------------------	------------------	------------------	------------------	------------------	------------------	------------------	------------------	------------------	------------------	------------------	------------------	------------------	------------------	------------------	------------------	------------------	------------------	------------------	------------------	------------------	------------------	------------------	------------------	------------------	------------------	------------------	------------------	------------------	------------------	------------------	------------------	------------------	------------------	------------------	------------------	------------------	------------------	------------------	------------------	------------------	------------------	------------------	------------------	------------------	------------------	------------------	------------------	------------------	------------------	------------------	------------------	------------------	------------------	------------------	------------------	------------------	------------------	------------------	------------------	------------------	------------------	------------------	------------------	------------------	------------------	------------------	------------------	------------------	------------------	------------------	------------------	------------------	------------------	------------------	------------------	------------------	------------------	------------------	------------------	------------------	------------------	------------------	------------------	------------------	------------------	------------------	------------------	------------------	------------------	------------------	------------------	------------------	------------------	------------------	------------------	------------------	------------------	------------------	------------------	------------------	------------------	------------------	------------------	------------------	------------------	------------------	------------------	------------------	------------------	------------------	------------------	------------------	------------------	------------------	------------------	------------------	------------------	------------------	------------------	------------------	------------------	------------------	------------------	------------------	------------------	------------------	------------------	------------------	------------------	------------------	------------------	------------------	------------------	------------------	------------------	------------------	------------------	------------------	------------------	------------------	------------------	------------------	------------------	------------------	------------------	------------------	------------------	------------------	------------------	------------------	------------------	------------------	------------------	------------------	------------------	------------------	------------------	------------------	------------------	------------------	------------------	------------------	------------------	------------------	------------------	------------------	------------------	------------------	------------------	------------------	------------------	------------------	------------------	---------------------

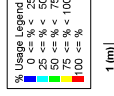
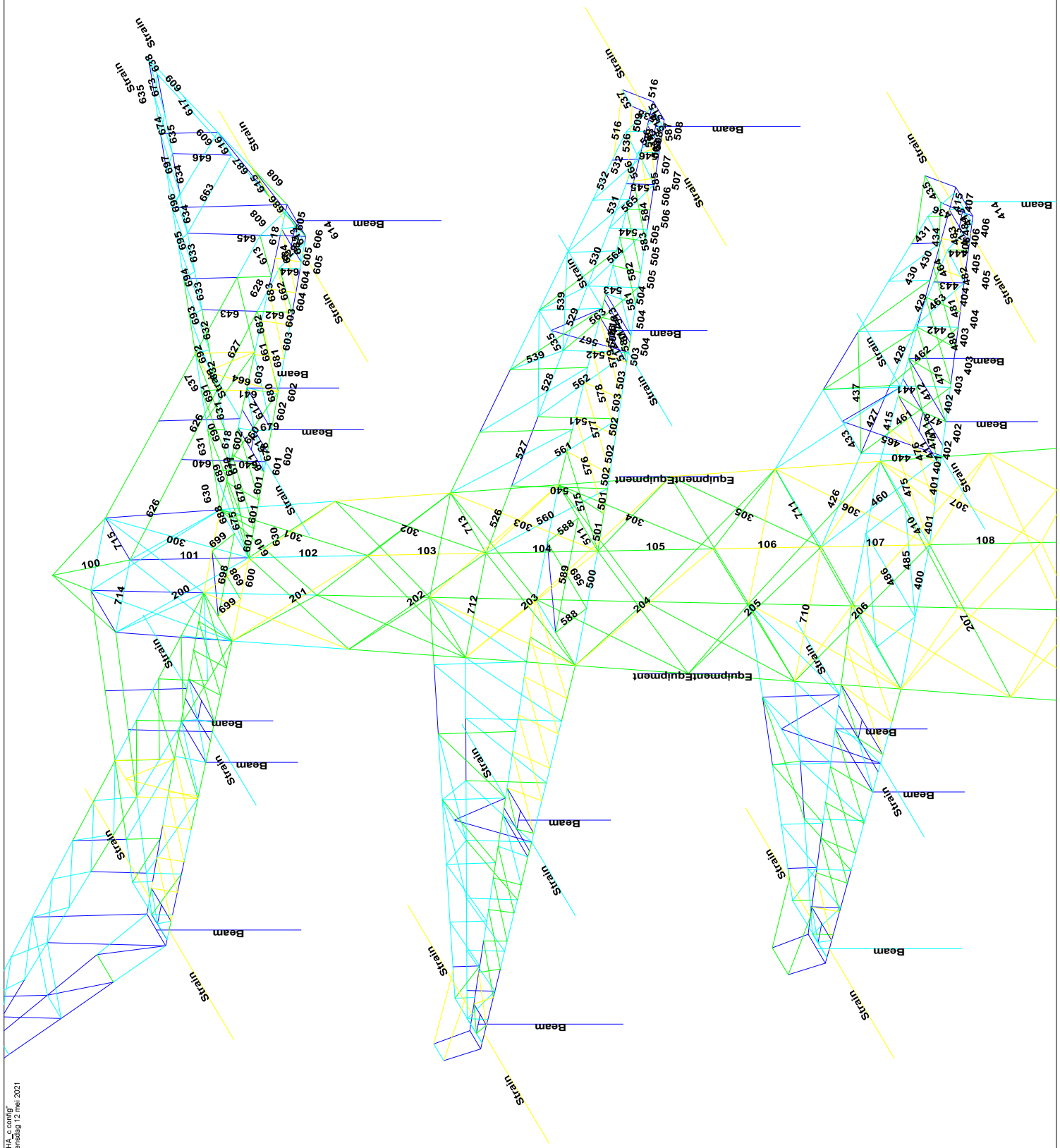



Date 15-7-2021  
Author MRE  
Version 2.0

Assessment of angle groups - Tower top

RLL-TBG  
HA4-6/C

Group Label	Description	Type	Profile	Steel (t)	Q <sub>1</sub>	Q <sub>2</sub>	Q <sub>3</sub>	Q <sub>4</sub>	Q <sub>5</sub>	Q <sub>6</sub>	Q <sub>7</sub>	Q <sub>8</sub>	Q <sub>9</sub>	Q <sub>10</sub>	Q <sub>11</sub>	Q <sub>12</sub>	Q <sub>13</sub>	Q <sub>14</sub>	Q <sub>15</sub>	Q <sub>16</sub>	Q <sub>17</sub>	Q <sub>18</sub>	Q <sub>19</sub>	Q <sub>20</sub>	Q <sub>21</sub>	Q <sub>22</sub>	Q <sub>23</sub>	Q <sub>24</sub>	Q <sub>25</sub>	Q <sub>26</sub>	Q <sub>27</sub>	Q <sub>28</sub>	Q <sub>29</sub>	Q <sub>30</sub>	Q <sub>31</sub>	Q <sub>32</sub>	Q <sub>33</sub>	Q <sub>34</sub>	Q <sub>35</sub>	Q <sub>36</sub>	Q <sub>37</sub>	Q <sub>38</sub>	Q <sub>39</sub>	Q <sub>40</sub>	Q <sub>41</sub>	Q <sub>42</sub>	Q <sub>43</sub>	Q <sub>44</sub>	Q <sub>45</sub>	Q <sub>46</sub>	Q <sub>47</sub>	Q <sub>48</sub>	Q <sub>49</sub>	Q <sub>50</sub>	Q <sub>51</sub>	Q <sub>52</sub>	Q <sub>53</sub>	Q <sub>54</sub>	Q <sub>55</sub>	Q <sub>56</sub>	Q <sub>57</sub>	Q <sub>58</sub>	Q <sub>59</sub>	Q <sub>60</sub>	Q <sub>61</sub>	Q <sub>62</sub>	Q <sub>63</sub>	Q <sub>64</sub>	Q <sub>65</sub>	Q <sub>66</sub>	Q <sub>67</sub>	Q <sub>68</sub>	Q <sub>69</sub>	Q <sub>70</sub>	Q <sub>71</sub>	Q <sub>72</sub>	Q <sub>73</sub>	Q <sub>74</sub>	Q <sub>75</sub>	Q <sub>76</sub>	Q <sub>77</sub>	Q <sub>78</sub>	Q <sub>79</sub>	Q <sub>80</sub>	Q <sub>81</sub>	Q <sub>82</sub>	Q <sub>83</sub>	Q <sub>84</sub>	Q <sub>85</sub>	Q <sub>86</sub>	Q <sub>87</sub>	Q <sub>88</sub>	Q <sub>89</sub>	Q <sub>90</sub>	Q <sub>91</sub>	Q <sub>92</sub>	Q <sub>93</sub>	Q <sub>94</sub>	Q <sub>95</sub>	Q <sub>96</sub>	Q <sub>97</sub>	Q <sub>98</sub>	Q <sub>99</sub>	Q <sub>100</sub>	Q <sub>101</sub>	Q <sub>102</sub>	Q <sub>103</sub>	Q <sub>104</sub>	Q <sub>105</sub>	Q <sub>106</sub>	Q <sub>107</sub>	Q <sub>108</sub>	Q <sub>109</sub>	Q <sub>110</sub>	Q <sub>111</sub>	Q <sub>112</sub>	Q <sub>113</sub>	Q <sub>114</sub>	Q <sub>115</sub>	Q <sub>116</sub>	Q <sub>117</sub>	Q <sub>118</sub>	Q <sub>119</sub>	Q <sub>120</sub>	Q <sub>121</sub>	Q <sub>122</sub>	Q <sub>123</sub>	Q <sub>124</sub>	Q <sub>125</sub>	Q <sub>126</sub>	Q <sub>127</sub>	Q <sub>128</sub>	Q <sub>129</sub>	Q <sub>130</sub>	Q <sub>131</sub>	Q <sub>132</sub>	Q <sub>133</sub>	Q <sub>134</sub>	Q <sub>135</sub>	Q <sub>136</sub>	Q <sub>137</sub>	Q <sub>138</sub>	Q <sub>139</sub>	Q <sub>140</sub>	Q <sub>141</sub>	Q <sub>142</sub>	Q <sub>143</sub>	Q <sub>144</sub>	Q <sub>145</sub>	Q <sub>146</sub>	Q <sub>147</sub>	Q <sub>148</sub>	Q <sub>149</sub>	Q <sub>150</sub>	Q <sub>151</sub>	Q <sub>152</sub>	Q <sub>153</sub>	Q <sub>154</sub>	Q <sub>155</sub>	Q <sub>156</sub>	Q <sub>157</sub>	Q <sub>158</sub>	Q <sub>159</sub>	Q <sub>160</sub>	Q <sub>161</sub>	Q <sub>162</sub>	Q <sub>163</sub>	Q <sub>164</sub>	Q <sub>165</sub>	Q <sub>166</sub>	Q <sub>167</sub>	Q <sub>168</sub>	Q <sub>169</sub>	Q <sub>170</sub>	Q <sub>171</sub>	Q <sub>172</sub>	Q <sub>173</sub>	Q <sub>174</sub>	Q <sub>175</sub>	Q <sub>176</sub>	Q <sub>177</sub>	Q <sub>178</sub>	Q <sub>179</sub>	Q <sub>180</sub>	Q <sub>181</sub>	Q <sub>182</sub>	Q <sub>183</sub>	Q <sub>184</sub>	Q <sub>185</sub>	Q <sub>186</sub>	Q <sub>187</sub>	Q <sub>188</sub>	Q <sub>189</sub>	Q <sub>190</sub>	Q <sub>191</sub>	Q <sub>192</sub>	Q <sub>193</sub>	Q <sub>194</sub>	Q <sub>195</sub>	Q <sub>196</sub>	Q <sub>197</sub>	Q <sub>198</sub>	Q <sub>199</sub>	Q <sub>200</sub>	Q <sub>201</sub>	Q <sub>202</sub>	Q <sub>203</sub>	Q <sub>204</sub>	Q <sub>205</sub>	Q <sub>206</sub>	Q <sub>207</sub>	Q <sub>208</sub>	Q <sub>209</sub>	Q <sub>210</sub>	Q <sub>211</sub>	Q <sub>212</sub>	Q <sub>213</sub>	Q <sub>214</sub>	Q <sub>215</sub>	Q <sub>216</sub>	Q <sub>217</sub>	Q <sub>218</sub>	Q <sub>219</sub>	Q <sub>220</sub>	Q <sub>221</sub>	Q <sub>222</sub>	Q <sub>223</sub>	Q <sub>224</sub>	Q <sub>225</sub>	Q <sub>226</sub>	Q <sub>227</sub>	Q <sub>228</sub>	Q <sub>229</sub>	Q <sub>230</sub>	Q <sub>231</sub>	Q <sub>232</sub>	Q <sub>233</sub>	Q <sub>234</sub>	Q <sub>235</sub>	Q <sub>236</sub>	Q <sub>237</sub>	Q <sub>238</sub>	Q <sub>239</sub>	Q <sub>240</sub>	Q <sub>241</sub>	Q <sub>242</sub>	Q <sub>243</sub>	Q <sub>244</sub>	Q <sub>245</sub>	Q <sub>246</sub>	Q <sub>247</sub>	Q <sub>248</sub>	Q <sub>249</sub>	Q <sub>250</sub>	Q <sub>251</sub>	Q <sub>252</sub>	Q <sub>253</sub>	Q <sub>254</sub>	Q <sub>255</sub>	Q <sub>256</sub>	Q <sub>257</sub>	Q <sub>258</sub>	Q <sub>259</sub>	Q <sub>260</sub>	Q <sub>261</sub>	Q <sub>262</sub>	Q <sub>263</sub>	Q <sub>264</sub>	Q <sub>265</sub>	Q <sub>266</sub>	Q <sub>267</sub>	Q <sub>268</sub>	Q <sub>269</sub>	Q <sub>270</sub>	Q <sub>271</sub>	Q <sub>272</sub>	Q <sub>273</sub>	Q <sub>274</sub>	Q <sub>275</sub>	Q <sub>276</sub>	Q <sub>277</sub>	Q <sub>278</sub>	Q <sub>279</sub>	Q <sub>280</sub>	Q <sub>281</sub>	Q <sub>282</sub>	Q <sub>283</sub>	Q <sub>284</sub>	Q <sub>285</sub>	Q <sub>286</sub>	Q <sub>287</sub>	Q <sub>288</sub>	Q <sub>289</sub>	Q <sub>290</sub>	Q <sub>291</sub>	Q <sub>292</sub>	Q <sub>293</sub>	Q <sub>294</sub>	Q <sub>295</sub>	Q <sub>296</sub>	Q <sub>297</sub>	Q <sub>298</sub>	Q <sub>299</sub>	Q <sub>300</sub>	Q <sub>301</sub>	Q <sub>302</sub>	Q <sub>303</sub>	Q <sub>304</sub>	Q <sub>305</sub>	Q <sub>306</sub>	Q <sub>307</sub>	Q <sub>308</sub>	Q <sub>309</sub>	Q <sub>310</sub>	Q <sub>311</sub>	Q <sub>312</sub>	Q <sub>313</sub>	Q <sub>314</sub>	Q <sub>315</sub>	Q <sub>316</sub>	Q <sub>317</sub>	Q <sub>318</sub>	Q <sub>319</sub>	Q <sub>320</sub>	Q <sub>321</sub>	Q <sub>322</sub>	Q <sub>323</sub>	Q <sub>324</sub>	Q <sub>325</sub>	Q <sub>326</sub>	Q <sub>327</sub>	Q <sub>328</sub>	Q <sub>329</sub>	Q <sub>330</sub>	Q <sub>331</sub>	Q <sub>332</sub>	Q <sub>333</sub>	Q <sub>334</sub>	Q <sub>335</sub>	Q <sub>336</sub>	Q <sub>337</sub>	Q <sub>338</sub>	Q <sub>339</sub>	Q <sub>340</sub>	Q <sub>341</sub>	Q <sub>342</sub>	Q <sub>343</sub>	Q <sub>344</sub>	Q <sub>345</sub>	Q <sub>346</sub>	Q <sub>347</sub>	Q <sub>348</sub>	Q <sub>349</sub>	Q <sub>350</sub>	Q <sub>351</sub>	Q <sub>352</sub>	Q <sub>353</sub>	Q <sub>354</sub>	Q <sub>355</sub>	Q <sub>356</sub>	Q <sub>357</sub>	Q <sub>358</sub>	Q <sub>359</sub>	Q <sub>360</sub>	Q <sub>361</sub>	Q <sub>362</sub>	Q <sub>363</sub>	Q <sub>364</sub>	Q <sub>365</sub>	Q <sub>366</sub>	Q <sub>367</sub>	Q <sub>368</sub>	Q <sub>369</sub>	Q <sub>370</sub>	Q <sub>371</sub>	Q <sub>372</sub>	Q <sub>373</sub>	Q <sub>374</sub>	Q <sub>375</sub>	Q <sub>376</sub>	Q <sub>377</sub>	Q <sub>378</sub>	Q <sub>379</sub>	Q <sub>380</sub>	Q <sub>381</sub>	Q <sub>382</sub>	Q <sub>383</sub>	Q <sub>384</sub>	Q <sub>385</sub>	Q <sub>386</sub>	Q <sub>387</sub>	Q <sub>388</sub>	Q <sub>389</sub>	Q <sub>390</sub>	Q <sub>391</sub>	Q <sub>392</sub>	Q <sub>393</sub>	Q <sub>394</sub>	Q <sub>395</sub>	Q <sub>396</sub>	Q <sub>397</sub>	Q <sub>398</sub>	Q <sub>399</sub>	Q <sub>400</sub>	Q <sub>401</sub>	Q <sub>402</sub>	Q <sub>403</sub>	Q <sub>404</sub>	Q <sub>405</sub>	Q <sub>406</sub>	Q <sub>407</sub>	Q <sub>408</sub>	Q <sub>409</sub>	Q <sub>410</sub>	Q <sub>411</sub>	Q <sub>412</sub>	Q <sub>413</sub>	Q <sub>414</sub>	Q <sub>415</sub>	Q <sub>416</sub>	Q <sub>417</sub>	Q <sub>418</sub>	Q <sub>419</sub>	Q <sub>420</sub>	Q <sub>421</sub>	Q <sub>422</sub>	Q <sub>423</sub>	Q <sub>424</sub>	Q <sub>425</sub>	Q <sub>426</sub>	Q <sub>427</sub>	Q <sub>428</sub>	Q <sub>429</sub>	Q <sub>430</sub>	Q <sub>431</sub>	Q <sub>432</sub>	Q <sub>433</sub>	Q <sub>434</sub>	Q <sub>435</sub>	Q <sub>436</sub>	Q <sub>437</sub>	Q <sub>438</sub>	Q <sub>439</sub>	Q <sub>440</sub>	Q <sub>441</sub>	Q <sub>442</sub>	Q <sub>443</sub>	Q <sub>444</sub>	Q <sub>445</sub>	Q <sub>446</sub>	Q <sub>447</sub>	Q <sub>448</sub>	Q <sub>449</sub>	Q <sub>450</sub>	Q <sub>451</sub>	Q <sub>452</sub>	Q <sub>453</sub>	Q <sub>454</sub>	Q <sub>455</sub>	Q <sub>456</sub>	Q <sub>457</sub>	Q <sub>458</sub>	Q <sub>459</sub>	Q <sub>460</sub>	Q <sub>461</sub>	Q <sub>462</sub>	Q <sub>463</sub>	Q <sub>464</sub>	Q <sub>465</sub>	Q <sub>466</sub>	Q <sub>467</sub>	Q <sub>468</sub>	Q <sub>469</sub>	Q <sub>470</sub>	Q <sub>471</sub>	Q <sub>472</sub>	Q <sub>473</sub>	Q <sub>474</sub>	Q <sub>475</sub>	Q <sub>476</sub>	Q <sub>477</sub>	Q <sub>478</sub>	Q <sub>479</sub>	Q <sub>480</sub>	Q <sub>481</sub>	Q <sub>482</sub>	Q <sub>483</sub>	Q <sub>484</sub>	Q <sub>485</sub>	Q <sub>486</sub>	Q <sub>487</sub>	Q <sub>488</sub>	Q <sub>489</sub>	Q <sub>490</sub>	Q <sub>491</sub>	Q <sub>492</sub>	Q <sub>493</sub>	Q <sub>494</sub>	Q <sub>495</sub>	Q <sub>496</sub>	Q <sub>497</sub>	Q <sub>498</sub>	Q <sub>499</sub>	Q <sub>500</sub>	Q <sub>501</sub>	Q <sub>502</sub>	Q <sub>503</sub>	Q <sub>504</sub>	Q <sub>505</sub>	Q <sub>506</sub>	Q <sub>507</sub>	Q <sub>508</sub>	Q <sub>509</sub>	Q <sub>510</sub>	Q <sub>511</sub>	Q <sub>512</sub>	Q <sub>513</sub>	Q <sub>514</sub>	Q <sub>515</sub>	Q <sub>516</sub>	Q <sub>517</sub>	Q <sub>518</sub>	Q <sub>519</sub>	Q <sub>520</sub>	Q <sub>521</sub>	Q <sub>522</sub>	Q <sub>523</sub>	Q <sub>524</sub>	Q <sub>525</sub>	Q <sub>526</sub>	Q <sub>527</sub>	Q <sub>528</sub>	Q <sub>529</sub>	Q <sub>530</sub>	Q <sub>531</sub>	Q <sub>532</sub>	Q <sub>533</sub>	Q <sub>534</sub>	Q <sub>535</sub>	Q <sub>536</sub>	Q <sub>537</sub>	Q <sub>538</sub>	Q <sub>539</sub>	Q <sub>540</sub>	Q <sub>541</sub>	Q <sub>542</sub>	Q <sub>543</sub>	Q <sub>544</sub>	Q <sub>545</sub>	Q <sub>546</sub>	Q <sub>547</sub>	Q <sub>548</sub>	Q <sub>549</sub>	Q <sub>550</sub>	Q <sub>551</sub>	Q <sub>552</sub>	Q <sub>553</sub>	Q <sub>554</sub>	Q <sub>555</sub>	Q <sub>556</sub>	Q <sub>557</sub>	Q <sub>558</sub>	Q <sub>559</sub>	Q <sub>560</sub>	Q <sub>561</sub>	Q <sub>562</sub>	Q <sub>563</sub>	Q <sub>564</sub>	Q <sub>565</sub>	Q <sub>566</sub>	Q <sub>567</sub>	Q <sub>568</sub>	Q <sub>569</sub>	Q <sub>570</sub>	Q <sub>571</sub>	Q <sub>572</sub>	Q <sub>573</sub>	Q <sub>574</sub>	Q <sub>575</sub>	Q <sub>576</sub>	Q <sub>577</sub>	Q <sub>578</sub>	Q <sub>579</sub>	Q <sub>580</sub>	Q <sub>581</sub>	Q <sub>582</sub>	Q <sub>583</sub>	Q <sub>584</sub>	Q <sub>585</sub>	Q <sub>586</sub>	Q <sub>587</sub>	Q <sub>588</sub>	Q <sub>589</sub>	Q <sub>590</sub>	Q <sub>591</sub>	Q <sub>592</sub>	Q <sub>593</sub>	Q <sub>594</sub>	Q <sub>595</sub>	Q <sub>596</sub>	Q <sub>597</sub>	Q <sub>598</sub>	Q <sub>599</sub>	Q <sub>600</sub>	Q <sub>601</sub>	Q <sub>602</sub>	Q <sub>603</sub>	Q <sub>604</sub>	Q <sub>605</sub>	Q <sub>606</sub>	Q <sub>607</sub>	Q <sub>608</sub>	Q <sub>609</sub>	Q <sub>610</sub>	Q <sub>611</sub>	Q <sub>612</sub>	Q <sub>613</sub>	Q <sub>614</sub>	Q <sub>615</sub>	Q <sub>616</sub>	Q <sub>617</sub>	Q <sub>618</sub>	Q <sub>619</sub>	Q <sub>620</sub>	Q <sub>621</sub>	Q <sub>622</sub>	Q <sub>623</sub>	Q <sub>624</sub>	Q <sub>625</sub>	Q <sub>626</sub>	Q <sub>627</sub>	Q <sub>628</sub>	Q <sub>629</sub>	Q <sub>630</sub>	Q <sub>631</sub>	Q <sub>632</sub>	Q <sub>633</sub>	Q <sub>634</sub>	Q <sub>635</sub>	Q <sub>636</sub>	Q <sub>637</sub>	Q <sub>638</sub>	Q <sub>639</sub>	Q <sub>640</sub>	Q <sub>641</sub>	Q <sub>642</sub>	Q <sub>643</sub>	Q <sub>644</sub>	Q <sub>645</sub>	Q <sub>646</sub>	Q <sub>647</sub>	Q <sub>648</sub>	Q <sub>649</sub>	Q <sub>650</sub>	Q <sub>651</sub>	Q <sub>652</sub>	Q <sub>653</sub>	Q <sub>654</sub>	Q <sub>655</sub>	Q <sub>656</sub>	Q <sub>657</sub>	Q <sub>658</sub>	Q <sub>659</sub>	Q <sub>660</sub>	Q <sub>661</sub>	Q <sub>662</sub>	Q <sub>663</sub>	Q <sub>664</sub>	Q <sub>665</sub>	Q <sub>666</sub>	Q <sub>667</sub>	Q <sub>668</sub>	Q <sub>669</sub>	Q <sub>670</sub>	Q <sub>671</sub>	Q <sub>672</sub>	Q <sub>673</sub>	Q <sub>674</sub>	Q <sub>675</sub>	Q <sub>676</sub>	Q <sub>677</sub>	Q <sub>678</sub>	Q <sub>679</sub>	Q <sub>680</sub>	Q <sub>681</sub>	Q <sub>682</sub>	Q <sub>683</sub>	Q <sub>684</sub>	Q <sub>685</sub>	Q <sub>686</sub>	Q <sub>687</sub>	Q <sub>688</sub>	Q <sub>689</sub>	Q <sub>690</sub>	Q <sub>691</sub>	Q <sub>692</sub>	Q <sub>693</sub>	Q <sub>694</sub>	Q <sub>695</sub>	Q <sub>696</sub>	Q <sub>697</sub>	Q <sub>698</sub>	Q <sub>699</sub>	Q <sub>700</sub>	Q <sub>701</sub>	Q <sub>702</sub>	Q <sub>703</sub>	Q <sub>704</sub>	Q <sub>705</sub>	Q <sub>706</sub>	Q <sub>707</sub>	Q <sub>708</sub>	Q <sub>709</sub>	Q <sub>710</sub>	Q <sub>711</sub>	Q <sub>712</sub>	Q <sub>713</sub>	Q <sub>714</sub>	Q <sub>715</sub>	Q <sub>716</sub>	Q <sub>717</sub>	Q <sub>718</sub>	Q <sub>719</sub>	Q <sub>720</sub>	Q <sub>721</sub>	Q <sub>722</sub>	Q <sub>723</sub>	Q <sub>724</sub>	Q <sub>725</sub>	Q <sub>726</sub>	Q <sub>727</sub>	Q <sub>728</sub>	Q <sub>729</sub>	Q <sub>730</sub>	Q <sub>731</sub>	Q <sub>732</sub>	Q <sub>733</sub>	Q <sub>734</sub>	Q <sub>735</sub>	Q <sub>736</sub>	Q <sub>737</sub>	Q <sub>738</sub>	Q <sub>739</sub>	Q <sub>740</sub>	Q <sub>741</sub>	Q <sub>742</sub>	Q <sub>743</sub>	Q <sub>744</sub>	Q <sub>745</sub>	Q <sub>746</sub>	Q <sub>747</sub>	Q <sub>748</sub>	Q <sub>749</sub>	Q <sub>750</sub>	Q <sub>751</sub>	Q <sub>752</sub>	Q <sub>753</sub>	Q <sub>754</sub>	Q <sub>755</sub>	Q <sub>756</sub>	Q <sub>757</sub>	Q <sub>758</sub>	Q <sub>759</sub>	Q <sub>760</sub>	Q <sub>761</sub>	Q <sub>762</sub>	Q <sub>763</sub>	Q <sub>764</sub>	Q <sub>765</sub>	Q <sub>766</sub>	Q <sub>767</sub>	Q <sub>768</sub>	Q <sub>769</sub>	Q <sub>770</sub>	Q <sub>771</sub>	Q <sub>772</sub>	Q <sub>773</sub>	Q <sub>774</sub>	Q <sub>775</sub>	Q <sub>776</sub>	Q <sub>777</sub>	Q <sub>778</sub>	Q <sub>779</sub>	Q <sub>780</sub>	Q <sub>781</sub>	Q <sub>782</sub>	Q <sub>783</sub>	Q <sub>784</sub>	Q <sub>785</sub>	Q <sub>786</sub>	Q <sub>787</sub>	Q <sub>788</sub>	Q <sub>789</sub>	Q <sub>790</sub>	Q <sub>791</sub>	Q <sub>792</sub>	Q <sub>793</sub>	Q <sub>794</sub>	Q <sub>795</sub>	Q <sub>796</sub>	Q <sub>797</sub>	Q <sub>798</sub>	Q <sub>799</sub>	Q <sub>800</sub>	Q <sub>801</sub>	Q <sub>802</sub>	Q <sub>803</sub>	Q <sub>804</sub>	Q <sub>805</sub>	Q <sub>806</sub>	Q <sub>807</sub>	Q <sub>808</sub>	Q <sub>809</sub>	Q <sub>810</sub>	Q <sub>811</sub>	Q <sub>812</sub>	Q <sub>813</sub>	Q <sub>814</sub>	Q <sub>815</sub>
-------------	-------------	------	---------	-----------	----------------	----------------	----------------	----------------	----------------	----------------	----------------	----------------	----------------	-----------------	-----------------	-----------------	-----------------	-----------------	-----------------	-----------------	-----------------	-----------------	-----------------	-----------------	-----------------	-----------------	-----------------	-----------------	-----------------	-----------------	-----------------	-----------------	-----------------	-----------------	-----------------	-----------------	-----------------	-----------------	-----------------	-----------------	-----------------	-----------------	-----------------	-----------------	-----------------	-----------------	-----------------	-----------------	-----------------	-----------------	-----------------	-----------------	-----------------	-----------------	-----------------	-----------------	-----------------	-----------------	-----------------	-----------------	-----------------	-----------------	-----------------	-----------------	-----------------	-----------------	-----------------	-----------------	-----------------	-----------------	-----------------	-----------------	-----------------	-----------------	-----------------	-----------------	-----------------	-----------------	-----------------	-----------------	-----------------	-----------------	-----------------	-----------------	-----------------	-----------------	-----------------	-----------------	-----------------	-----------------	-----------------	-----------------	-----------------	-----------------	-----------------	-----------------	-----------------	-----------------	-----------------	-----------------	-----------------	-----------------	-----------------	------------------	------------------	------------------	------------------	------------------	------------------	------------------	------------------	------------------	------------------	------------------	------------------	------------------	------------------	------------------	------------------	------------------	------------------	------------------	------------------	------------------	------------------	------------------	------------------	------------------	------------------	------------------	------------------	------------------	------------------	------------------	------------------	------------------	------------------	------------------	------------------	------------------	------------------	------------------	------------------	------------------	------------------	------------------	------------------	------------------	------------------	------------------	------------------	------------------	------------------	------------------	------------------	------------------	------------------	------------------	------------------	------------------	------------------	------------------	------------------	------------------	------------------	------------------	------------------	------------------	------------------	------------------	------------------	------------------	------------------	------------------	------------------	------------------	------------------	------------------	------------------	------------------	------------------	------------------	------------------	------------------	------------------	------------------	------------------	------------------	------------------	------------------	------------------	------------------	------------------	------------------	------------------	------------------	------------------	------------------	------------------	------------------	------------------	------------------	------------------	------------------	------------------	------------------	------------------	------------------	------------------	------------------	------------------	------------------	------------------	------------------	------------------	------------------	------------------	------------------	------------------	------------------	------------------	------------------	------------------	------------------	------------------	------------------	------------------	------------------	------------------	------------------	------------------	------------------	------------------	------------------	------------------	------------------	------------------	------------------	------------------	------------------	------------------	------------------	------------------	------------------	------------------	------------------	------------------	------------------	------------------	------------------	------------------	------------------	------------------	------------------	------------------	------------------	------------------	------------------	------------------	------------------	------------------	------------------	------------------	------------------	------------------	------------------	------------------	------------------	------------------	------------------	------------------	------------------	------------------	------------------	------------------	------------------	------------------	------------------	------------------	------------------	------------------	------------------	------------------	------------------	------------------	------------------	------------------	------------------	------------------	------------------	------------------	------------------	------------------	------------------	------------------	------------------	------------------	------------------	------------------	------------------	------------------	------------------	------------------	------------------	------------------	------------------	------------------	------------------	------------------	------------------	------------------	------------------	------------------	------------------	------------------	------------------	------------------	------------------	------------------	------------------	------------------	------------------	------------------	------------------	------------------	------------------	------------------	------------------	------------------	------------------	------------------	------------------	------------------	------------------	------------------	------------------	------------------	------------------	------------------	------------------	------------------	------------------	------------------	------------------	------------------	------------------	------------------	------------------	------------------	------------------	------------------	------------------	------------------	------------------	------------------	------------------	------------------	------------------	------------------	------------------	------------------	------------------	------------------	------------------	------------------	------------------	------------------	------------------	------------------	------------------	------------------	------------------	------------------	------------------	------------------	------------------	------------------	------------------	------------------	------------------	------------------	------------------	------------------	------------------	------------------	------------------	------------------	------------------	------------------	------------------	------------------	------------------	------------------	------------------	------------------	------------------	------------------	------------------	------------------	------------------	------------------	------------------	------------------	------------------	------------------	------------------	------------------	------------------	------------------	------------------	------------------	------------------	------------------	------------------	------------------	------------------	------------------	------------------	------------------	------------------	------------------	------------------	------------------	------------------	------------------	------------------	------------------	------------------	------------------	------------------	------------------	------------------	------------------	------------------	------------------	------------------	------------------	------------------	------------------	------------------	------------------	------------------	------------------	------------------	------------------	------------------	------------------	------------------	------------------	------------------	------------------	------------------	------------------	------------------	------------------	------------------	------------------	------------------	------------------	------------------	------------------	------------------	------------------	------------------	------------------	------------------	------------------	------------------	------------------	------------------	------------------	------------------	------------------	------------------	------------------	------------------	------------------	------------------	------------------	------------------	------------------	------------------	------------------	------------------	------------------	------------------	------------------	------------------	------------------	------------------	------------------	------------------	------------------	------------------	------------------	------------------	------------------	------------------	------------------	------------------	------------------	------------------	------------------	------------------	------------------	------------------	------------------	------------------	------------------	------------------	------------------	------------------	------------------	------------------	------------------	------------------	------------------	------------------	------------------	------------------	------------------	------------------	------------------	------------------	------------------	------------------	------------------	------------------	------------------	------------------	------------------	------------------	------------------	------------------	------------------	------------------	------------------	------------------	------------------	------------------	------------------	------------------	------------------	------------------	------------------	------------------	------------------	------------------	------------------	------------------	------------------	------------------	------------------	------------------	------------------	------------------	------------------	------------------	------------------	------------------	------------------	------------------	------------------	------------------	------------------	------------------	------------------	------------------	------------------	------------------	------------------	------------------	------------------	------------------	------------------	------------------	------------------	------------------	------------------	------------------	------------------	------------------	------------------	------------------	------------------	------------------	------------------	------------------	------------------	------------------	------------------	------------------	------------------	------------------	------------------	------------------	------------------	------------------	------------------	------------------	------------------	------------------	------------------	------------------	------------------	------------------	------------------	------------------	------------------	------------------	------------------	------------------	------------------	------------------	------------------	------------------	------------------	------------------	------------------	------------------	------------------	------------------	------------------	------------------	------------------	------------------	------------------	------------------	------------------	------------------	------------------	------------------	------------------	------------------	------------------	------------------	------------------	------------------	------------------	------------------	------------------	------------------	------------------	------------------	------------------	------------------	------------------	------------------	------------------	------------------	------------------	------------------	------------------	------------------	------------------	------------------	------------------	------------------	------------------	------------------	------------------	------------------	------------------	------------------	------------------	------------------	------------------	------------------	------------------	------------------	------------------	------------------	------------------	------------------	------------------	------------------	------------------	------------------	------------------	------------------	------------------	------------------	------------------	------------------	------------------	------------------	------------------	------------------	------------------	------------------	------------------	------------------	------------------	------------------	------------------	------------------	------------------	------------------	------------------	------------------	------------------	------------------	------------------	------------------	------------------	------------------	------------------	------------------	------------------	------------------	------------------	------------------	------------------	------------------	------------------	------------------	------------------	------------------	------------------	------------------	------------------	------------------	------------------	------------------	------------------	------------------	------------------	------------------	------------------	------------------	------------------	------------------	------------------	------------------	------------------	------------------	------------------	------------------	------------------	------------------	------------------	------------------	------------------	------------------	------------------	------------------	------------------	------------------	------------------	------------------	------------------	------------------	------------------	------------------	------------------	------------------	------------------	------------------	------------------	------------------	------------------	------------------	------------------	------------------	------------------	------------------	------------------	------------------	------------------	------------------	------------------	------------------	------------------	------------------	------------------	------------------	------------------	------------------	------------------	------------------	------------------	------------------	------------------	------------------	------------------	------------------	------------------	------------------	------------------	------------------	------------------	------------------	------------------	------------------	------------------	------------------	------------------	------------------	------------------	------------------	------------------	------------------	------------------	------------------	------------------	------------------	------------------	------------------	------------------	------------------	------------------	------------------	------------------	------------------	------------------	------------------	------------------	------------------	------------------









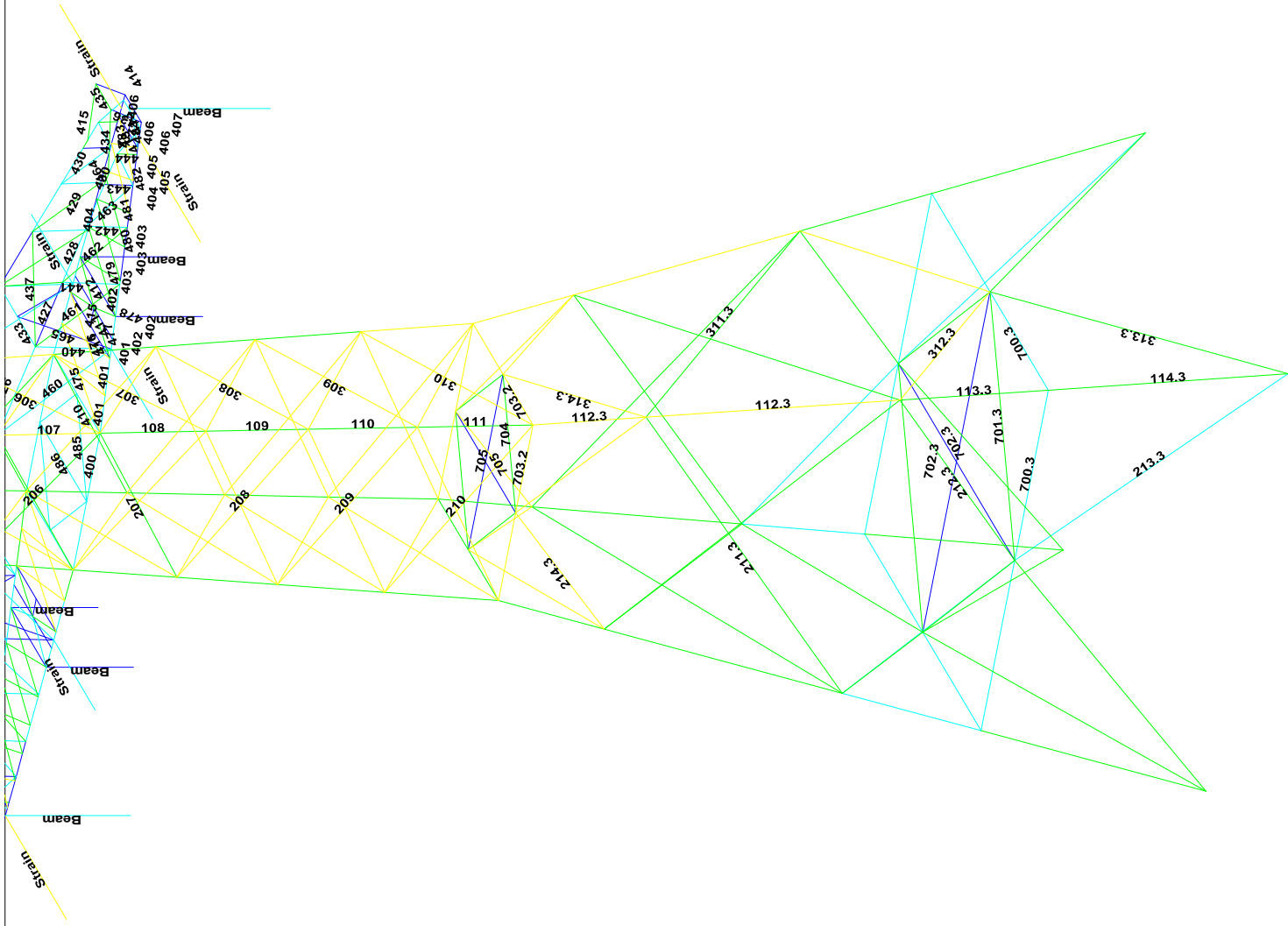



Project: ZW-Oost  
Mast: H\_C

**Angle check**

NEN-EN1993-1-1 and EN1993-3-1

Datum: 2021-05-11  
Auteur: TBR  
Versie: 3.0

<b>Member name</b>	<b>Group 108-109</b>	<b>Conclusion</b>
<b>Section</b>	<b>XEA 200x200x24</b>	U.C. (compression) <b>0.72 &lt; 1,0 OK</b>
		U.C. (tension) <b>0.48 &lt; 1,0 OK</b>

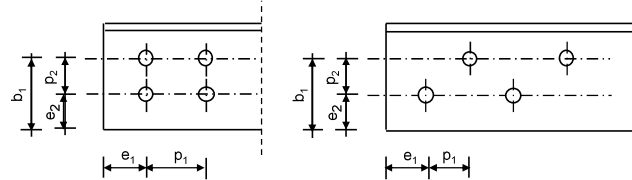
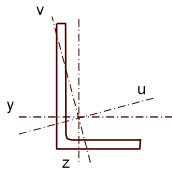

Steel grade **S355**

**Member loads**  
Compressive force  $N_{Ed} =$  **3780 kN**  
Tensile force **-3352 kN**

**Crossing diagonal loads**  
Applicable: **No**  
Min. tensile force diagonal 2 **1 kN**  
Max. comp. force diagonal 1 **1 kN**  
Position crossing diagonal y-axis **1.00 m**

**Construction loads**  
Vertical construction load **1.0 kN**  
Member angle to horizontal **0 °**  
Bending around axis **y-axis**

**Geometry**  
System length y-axis  $L_{y,buc} =$  **1.66 m**  
System length z-axis  $L_{z,buc} =$  **1.66 m**  
System length v-axis  $L_{v,buc} =$  **1.66 m**  
System length x-axis  $L_{tk,buc} =$  **1.66 m**  
Member type **Leg**  
Type bracing **Non staggered**

**End conditions**  
Begin **Continuous**  
End **Continuous**  
Restraint code TOWER **C4**

**Bolted connection**  
Bolt type **M24**  
Bolt class **8.8**  
Number of bolts per leg **6** (24 total)  
Shearplane through **Thread**  
Boltpattern **Zigzag**  
Boltpattern (leg-member only) **Staggered**

End distance  $e_1 =$  **55 mm** **Ok**  
Separation distance //  $p_1 =$  **70 mm** **Ok**  
Separation distance |  $p_2 =$  **100 mm** **Ok**  
End distance  $e_2 =$  **50 mm** **Ok**  
Double strap or single strap **Double**  
Tie plate  $b_p =$  **230 mm** **OK**  
 $t_p =$  **15 mm** **OK**  
 $e_2 =$  **40 mm** **OK**

A **18118 mm<sup>2</sup>**  
G **144.9 kg/m**  
Partial safety factor  $\gamma_{F;Q} =$  **1.50**  
Material factors  $\gamma_{M0} =$  **1.00**  
 $\gamma_{M1} =$  **1.00**  
 $\gamma_{M2} =$  **1.25**  
**Shear strength bolt**  $F_{v;Rd} =$  **135.6 kN**

**Slenderness**  $\lambda_{max} = L / i :$  **22 -**  
Allowed: **120 OK**

**Bending due to vertical construction load**  
 $M_{y,Ed} = 1/4 F_{Ed} L_{pr} =$  **0.62 kNm**  
U.C. = **0.00 < 1,00 OK**

**Results stability**

	$\lambda_{eff,rel}$	$\lambda_{eff}$	$\lambda_{eff,mod}$	$\chi_{buc}$	$\eta$	$N_{b,Rd} = \eta \chi A_f \gamma / \gamma_{M1}$
$L_{y,buc} =$ 1.66 m	0.26	1,00 I	0.26	0.98	1	6299 <b>0.60</b>
$L_{z,buc} =$ 1.66 m	0.26	1,00 I	0.26	0.98	1	6299 <b>0.60</b>
$L_{v,buc} =$ 1.66 m	0.28	0,10+0,80 I	0.28	0.97	1	6237 <b>0.61</b>
$L_{tk,buc} =$ 1.66 m	0.55			0.81	1	5229 <b>0.72</b>

**Bolted connection**

	$F_{Rd}$ (kN)	U.C.		$F_{Rd}$ (kN)	U.C.
Compression			Tension		
Cross section angle $F_{u;Rd} =$	6432	<b>0.59</b>	Net section angle $F_{u;Rd} =$	6987	<b>0.48</b>
Cross section tie plate $F_{u;Rd} =$	8094	<b>0.47</b>	Net section tie plate $F_{u;Rd} =$	6943	<b>0.48</b>
Shear strength $F_{v;Rd} =$	8675	<b>0.44</b>	Block shear $F_{u;Rd} =$	10634	<b>0.32</b>
Bearing strength $F_{b;Rd} =$	11695	<b>0.32</b>	Shear strength $F_{v;Rd} =$	8675	<b>0.39</b>
Combined effect $F_{v;Rd} =$	8675	<b>0.44</b>	Bearing strength $F_{b;Rd} =$	11825	<b>0.28</b>
		elastisch	Combined effect $F_{v;Rd} =$	8675	<b>0.39</b>
					elastisch

Project: ZW-Oost  
Mast: H\_C

### Angle check

NEN-EN1993-1-1 and EN1993-3-1

Datum: 2021-05-10  
Auteur: TBR  
Versie: 3.0

Member name	Group 110-111	Conclusion
Section	XEA 250x250x24	U.C. (compression) <b>0.75 &lt; 1,0 OK</b>
		U.C. (tension) <b>0.61 &lt; 1,0 OK</b>

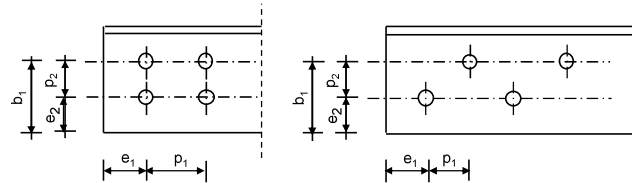
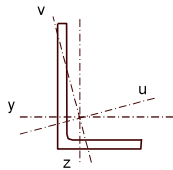

Steel grade **S355**

#### Member loads

Compressive force  $N_{Ed} =$  **4689 kN**  
Tensile force **-4222 kN**

#### Crossing diagonal loads

Applicable: **No**  
Min. tensile force diagonal 2 **1 kN**  
Max. comp. force diagonal 1 **1 kN**  
Position crossing diagonal y-axis **1.00 m**

#### Construction loads

Vertical construction load **1.0 kN**  
Member angle to horizontal **0 °**  
Bending around axis **y-axis**

#### Geometry

System length y-axis  $L_{y,buc} =$  **1.81 m**  
System length z-axis  $L_{z,buc} =$  **1.81 m**  
System length v-axis  $L_{v,buc} =$  **1.81 m**  
System length x-axis  $L_{tk,buc} =$  **1.81 m**  
Member type **Leg**  
Type bracing **Non staggered**

#### End conditions

Begin **Continuous**  
End **Continuous**  
Restraint code TOWER **C4**

#### Bolted connection

Bolt type **M24**  
Bolt class **8.8**  
Number of bolts per leg **6** (24 total)  
Shearplane through **Thread**  
Boltpattern **Zigzag**  
Boltpattern (leg-member only) **Staggered**

End distance  $e_1 =$  **55 mm** **Ok**  
Separation distance //  $p_1 =$  **70 mm** **Ok**  
Separation distance |  $p_2 =$  **100 mm** **Ok**  
End distance  $e_2 =$  **50 mm** **Ok**  
Double strap or single strap **Double**  
Tie plate  $b_p =$  **230 mm** **OK**  
 $t_p =$  **15 mm** **OK**  
 $e_2 =$  **40 mm** **OK**

A **23036 mm<sup>2</sup>**  
G **184.3 kg/m**  
Partial safety factor  $\gamma_{f;Q} =$  **1.50**  
Material factors  $\gamma_{M0} =$  **1.00**  
 $\gamma_{M1} =$  **1.00**  
 $\gamma_{M2} =$  **1.25**  
Shear strength bolt  $F_{v;Rd} =$  **135.6 kN**

Slenderness  $\lambda_{max} = L / i :$  **19 -**  
Allowed: **120 OK**

#### Bending due to vertical construction load

$M_{y,Ed} = 1/4 F_{Ed} L_{pr} =$  **0.68 kNm**  
U.C. = **0.00 < 1,00 OK**

#### Results stability

	$\lambda_{eff,rel}$	$\lambda_{eff}$	$\lambda_{eff,mod}$	$\chi_{buc}$	$\eta$	$N_{b,Rd} = \eta \chi A_f \gamma / \gamma_{M1}$
$L_{y,buc} =$ 1.81 m	0.23	1,00 I	0.23	0.99	1	8098 <b>0.58</b>
$L_{z,buc} =$ 1.81 m	0.23	1,00 I	0.23	0.99	1	8098 <b>0.58</b>
$L_{v,buc} =$ 1.81 m	0.25	0,10+0,80 I	0.25	0.98	1	8045 <b>0.58</b>
$L_{tk,buc} =$ 1.81 m	0.64			0.76	1	6250 <b>0.75</b>

#### Bolted connection

Compression	$F_{Rd}$ (kN)	U.C.	Tension	$F_{Rd}$ (kN)	U.C.
Cross section angle	$F_{u;Rd} =$ 8178	<b>0.57</b>	Net section angle	$F_{u;Rd} =$ 6987	<b>0.60</b>
Cross section tie plate	$F_{u;Rd} =$ 8094	<b>0.58</b>	Net section tie plate	$F_{u;Rd} =$ 6943	<b>0.61</b>
Shear strength	$F_{v;Rd} =$ 8675	<b>0.54</b>	Block shear	$F_{u;Rd} =$ 10634	<b>0.40</b>
Bearing strength	$F_{b;Rd} =$ 11695	<b>0.40</b>	Shear strength	$F_{v;Rd} =$ 8675	<b>0.49</b>
Combined effect	$F_{v;Rd} =$ 8675	<b>0.54</b> elastisch	Bearing strength	$F_{b;Rd} =$ 11825	<b>0.36</b>
			Combined effect	$F_{v;Rd} =$ 8675	<b>0.49</b> elastisch

Project: ZW-Oost  
Mast: H\_C

**Angle check**

NEN-EN1993-1-1 and EN1993-3-1

Datum: 2021-05-10  
Auteur: TBR  
Versie: 3.0

<b>Member name</b>	<b>Group 112.1-113.1-114.1</b>	<b>Conclusion</b>
<b>Section</b>	<b>XEA 250x250x24</b>	U.C. (compression) <b>0.78 &lt; 1,0 OK</b>
		U.C. (tension) <b>0.62 &lt; 1,0 OK</b>

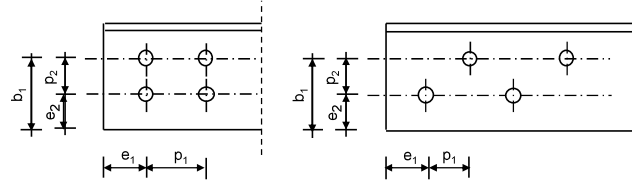
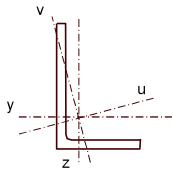

Steel grade **S355**

**Member loads**  
Compressive force  $N_{Ed} =$  **4867 kN**  
Tensile force **-4327 kN**

**Crossing diagonal loads**  
Applicable: **No**  
Min. tensile force diagonal 2 **1 kN**  
Max. comp. force diagonal 1 **1 kN**  
Position crossing diagonal y-axis **1.00 m**

**Construction loads**  
Vertical construction load **1.0 kN**  
Member angle to horizontal **0 °**  
Bending around axis **y-axis**

**Geometry**  
System length y-axis  $L_{y,buc} =$  **2.00 m**  
System length z-axis  $L_{z,buc} =$  **2.00 m**  
System length v-axis  $L_{v,buc} =$  **2.00 m**  
System length x-axis  $L_{tk,buc} =$  **2.00 m**  
Member type **Leg**  
Type bracing **Non staggered**

**End conditions**  
Begin **Continuous**  
End **Continuous**  
Restraint code TOWER **C4**

**Bolted connection**  
Bolt type **M24**  
Bolt class **8.8**  
Number of bolts per leg **6** (24 total)  
Shearplane through **Thread**  
Boltpattern **Zigzag**  
Boltpattern (leg-member only) **Staggered**

End distance  $e_1 =$  **55 mm** **Ok**  
Separation distance //  $p_1 =$  **70 mm** **Ok**  
Separation distance |  $p_2 =$  **100 mm** **Ok**  
End distance  $e_2 =$  **50 mm** **Ok**  
Double strap or single strap **Double**  
Tie plate  $b_p =$  **230 mm** **OK**  
 $t_p =$  **15 mm** **OK**  
 $e_2 =$  **40 mm** **OK**

A **23036 mm<sup>2</sup>**  
G **184.3 kg/m**  
Partial safety factor  $\gamma_{f;Q} =$  **1.50**  
Material factors  $\gamma_{M0} =$  **1.00**  
 $\gamma_{M1} =$  **1.00**  
 $\gamma_{M2} =$  **1.25**  
Shear strength bolt  $F_{v;b;Rd} =$  **135.6 kN**

**Slenderness**  $\lambda_{max} = L / i :$  **21 -**  
Allowed: **120 OK**

**Bending due to vertical construction load**  
 $M_{y,Ed} = 1/4 F_{Ed} L_{pr} =$  **0.75 kNm**  
U.C. = **0.00 < 1,00 OK**

**Results stability**

	$\lambda_{eff,rel}$	$\lambda_{eff}$	$\lambda_{eff,mod}$	$\chi_{buc}$	$\eta$	$N_{b,Rd} = \eta \chi A_f \gamma / \gamma_{M1}$
$L_{y,buc} =$ 2.00 m	0.25	1,00 I	0.25	0.98	1	8028 <b>0.61</b>
$L_{z,buc} =$ 2.00 m	0.25	1,00 I	0.25	0.98	1	8028 <b>0.61</b>
$L_{v,buc} =$ 2.00 m	0.27	0,10+0,80 I	0.27	0.97	1	7969 <b>0.61</b>
$L_{tk,buc} =$ 2.00 m	0.64			0.76	1	6209 <b>0.78</b>

**Bolted connection**

	$F_{Rd}$ (kN)	U.C.		$F_{Rd}$ (kN)	U.C.
Compression			Tension		
Cross section angle $F_{u;Rd} =$	8178	<b>0.60</b>	Net section angle $F_{u;Rd} =$	6987	<b>0.62</b>
Cross section tie plate $F_{u;Rd} =$	8094	<b>0.60</b>	Net section tie plate $F_{u;Rd} =$	6943	<b>0.62</b>
Shear strength $F_{v;Rd} =$	8675	<b>0.56</b>	Block shear $F_{u;Rd} =$	10634	<b>0.41</b>
Bearing strength $F_{b;Rd} =$	11695	<b>0.42</b>	Shear strength $F_{v;Rd} =$	8675	<b>0.50</b>
Combined effect $F_{v;Rd} =$	8675	<b>0.56</b> elastisch	Bearing strength $F_{b;Rd} =$	11825	<b>0.37</b>
			Combined effect $F_{v;Rd} =$	8675	<b>0.50</b> elastisch

Project: ZW-Oost  
Mast: H\_C

### Angle check

NEN-EN1993-1-1 and EN1993-3-1

Datum: 2021-05-10  
Auteur: TBR  
Versie: 3.0

Member name	Group 112.2-113.2-114.2	Conclusion
Section	XEA 250x250x24	U.C. (compression) <b>0.83 &lt; 1,0 OK</b>
		U.C. (tension) <b>0.66 &lt; 1,0 OK</b>

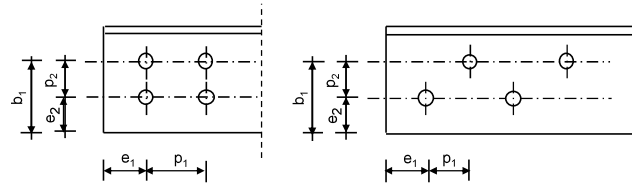
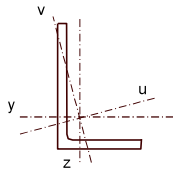

Steel grade **S355**

#### Member loads

Compressive force  $N_{Ed} =$  **5130 kN**  
Tensile force **-4595 kN**

#### Crossing diagonal loads

Applicable: **No**  
Min. tensile force diagonal 2 **1 kN**  
Max. comp. force diagonal 1 **1 kN**  
Position crossing diagonal y-axis **1.00 m**

#### Construction loads

Vertical construction load **1.0 kN**  
Member angle to horizontal **0 °**  
Bending around axis **y-axis**

#### Geometry

System length y-axis  $L_{y,buc} =$  **2.08 m**  
System length z-axis  $L_{z,buc} =$  **2.08 m**  
System length v-axis  $L_{v,buc} =$  **2.08 m**  
System length x-axis  $L_{tk,buc} =$  **2.08 m**  
Member type **Leg**  
Type bracing **Non staggered**

#### End conditions

Begin **Continuous**  
End **Continuous**  
Restraint code TOWER **C4**

#### Bolted connection

Bolt type **M24**  
Bolt class **8.8**  
Number of bolts per leg **6** (24 total)  
Shearplane through **Thread**  
Bolt pattern **Zigzag**  
Bolt pattern (leg-member only) **Staggered**

End distance  $e_1 =$  **55 mm** **Ok**  
Separation distance //  $p_1 =$  **70 mm** **Ok**  
Separation distance |  $p_2 =$  **100 mm** **Ok**  
End distance  $e_2 =$  **50 mm** **Ok**  
Double strap or single strap **Double**  
Tie plate  $b_p =$  **230 mm** **OK**  
 $t_p =$  **15 mm** **OK**  
 $e_2 =$  **40 mm** **OK**

A **23036 mm<sup>2</sup>**  
G **184.3 kg/m**  
Partial safety factor  $\gamma_{f;Q} =$  **1.50**  
Material factors  $\gamma_{M0} =$  **1.00**  
 $\gamma_{M1} =$  **1.00**  
 $\gamma_{M2} =$  **1.25**  
Shear strength bolt  $F_{v;Rd} =$  **135.6 kN**

Slenderness  $\lambda_{max} = L / i :$  **22 -**  
Allowed: **120** **OK**

#### Bending due to vertical construction load

$M_{y,Ed} = 1/4 F_{Ed} L_{pr} =$  **0.78 kNm**  
U.C. = **0.00 < 1,00 OK**

#### Results stability

	$\lambda_{eff,rel}$	$\lambda_{eff}$	$\lambda_{eff,mod}$	$\chi_{buc}$	$\eta$	$N_{b,Rd} = \eta \chi A_f \gamma / \gamma_{M1}$
$L_{y,buc} =$ 2.08 m	0.26	1,00 I	0.26	0.98	1	7998 <b>0.64</b>
$L_{z,buc} =$ 2.08 m	0.26	1,00 I	0.26	0.98	1	7998 <b>0.64</b>
$L_{v,buc} =$ 2.08 m	0.28	0,10+0,80 I	0.28	0.97	1	7937 <b>0.65</b>
$L_{tk,buc} =$ 2.08 m	0.65			0.76	1	6194 <b>0.83</b>

#### Bolted connection

Compression	$F_{Rd}$ (kN)	U.C.	Tension	$F_{Rd}$ (kN)	U.C.
Cross section angle	$F_{u;Rd} =$ 8178	<b>0.63</b>	Net section angle	$F_{u;Rd} =$ 6987	<b>0.66</b>
Cross section tie plate	$F_{u;Rd} =$ 8094	<b>0.63</b>	Net section tie plate	$F_{u;Rd} =$ 6943	<b>0.66</b>
Shear strength	$F_{v;Rd} =$ 8675	<b>0.59</b>	Block shear	$F_{u;Rd} =$ 10634	<b>0.43</b>
Bearing strength	$F_{b;Rd} =$ 11695	<b>0.44</b>	Shear strength	$F_{v;Rd} =$ 8675	<b>0.53</b>
Combined effect	$F_{v;Rd} =$ 8675	<b>0.59</b> elastisch	Bearing strength	$F_{b;Rd} =$ 11825	<b>0.39</b>
			Combined effect	$F_{v;Rd} =$ 8675	<b>0.53</b> elastisch

Project: ZW-Oost  
Mast: H\_C

### Angle check

NEN-EN1993-1-1 and EN1993-3-1

Datum: 2021-05-10  
Auteur: TBR  
Versie: 3.0

<b>Member name</b>	<b>Group 112.3-113.3-114.3</b>	<b>Conclusion</b>
<b>Section</b>	<b>XEA 250x250x24</b>	U.C. (compression) <b>0.84 &lt; 1,0 OK</b>
		U.C. (tension) <b>0.66 &lt; 1,0 OK</b>

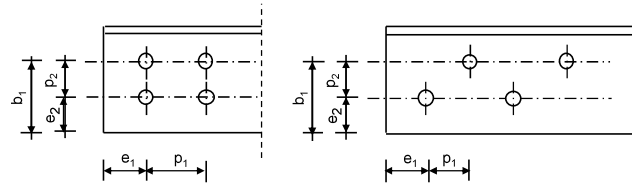
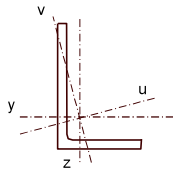

Steel grade **S355**

#### Member loads

Compressive force  $N_{Ed} =$  **5156 kN**  
Tensile force **-4605 kN**

#### Crossing diagonal loads

Applicable: **No**  
Min. tensile force diagonal 2 **1 kN**  
Max. comp. force diagonal 1 **1 kN**  
Position crossing diagonal y-axis **1.00 m**

#### Construction loads

Vertical construction load **1.0 kN**  
Member angle to horizontal **0 °**  
Bending around axis **y-axis**

#### Geometry

System length y-axis  $L_{y,buc} =$  **2.34 m**  
System length z-axis  $L_{z,buc} =$  **2.34 m**  
System length v-axis  $L_{v,buc} =$  **2.34 m**  
System length x-axis  $L_{tk,buc} =$  **2.34 m**  
Member type **Leg**  
Type bracing **Non staggered**

#### End conditions

Begin **Continuous**  
End **Continuous**  
Restraint code TOWER **C4**

#### Bolted connection

Bolt type **M24**  
Bolt class **8.8**  
Number of bolts per leg **6** (24 total)  
Shearplane through **Thread**  
Bolt pattern **Zigzag**  
Bolt pattern (leg-member only) **Staggered**

End distance  $e_1 =$  **55 mm** **Ok**  
Separation distance //  $p_1 =$  **70 mm** **Ok**  
Separation distance |  $p_2 =$  **100 mm** **Ok**  
End distance  $e_2 =$  **50 mm** **Ok**  
Double strap or single strap **Double**  
Tie plate  $b_p =$  **230 mm** **OK**  
 $t_p =$  **15 mm** **OK**  
 $e_2 =$  **40 mm** **OK**

A **23036 mm<sup>2</sup>**  
G **184.3 kg/m**  
Partial safety factor  $\gamma_{F;Q} =$  **1.50**  
Material factors  $\gamma_{M0} =$  **1.00**  
 $\gamma_{M1} =$  **1.00**  
 $\gamma_{M2} =$  **1.25**  
Shear strength bolt  $F_{v;Rd} =$  **135.6 kN**

Slenderness  $\lambda_{max} = L / i :$  **24 -**  
Allowed: **120 OK**

#### Bending due to vertical construction load

$M_{y,Ed} = 1/4 F_{Ed} L_{pr} =$  **0.88 kNm**  
U.C. = **0.00 < 1,00 OK**

#### Results stability

	$\lambda_{eff,rel}$	$\lambda_{eff}$	$\lambda_{eff,mod}$	$\chi_{buc}$	$\eta$	$N_{b,Rd} = \eta \chi A_f \gamma / \gamma_{M1}$
$L_{y,buc} =$ 2.34 m	0.29	1,00 I	0.29	0.97	1	7902 <b>0.65</b>
$L_{z,buc} =$ 2.34 m	0.29	1,00 I	0.29	0.97	1	7902 <b>0.65</b>
$L_{v,buc} =$ 2.34 m	0.32	0,10+0,80 I	0.32	0.96	1	7831 <b>0.66</b>
$L_{tk,buc} =$ 2.34 m	0.65			0.75	1	6155 <b>0.84</b>

#### Bolted connection

	$F_{Rd}$ (kN)	U.C.		$F_{Rd}$ (kN)	U.C.
Compression			Tension		
Cross section angle $F_{u;Rd} =$	8178	<b>0.63</b>	Net section angle $F_{u;Rd} =$	6987	<b>0.66</b>
Cross section tie plate $F_{u;Rd} =$	8094	<b>0.64</b>	Net section tie plate $F_{u;Rd} =$	6943	<b>0.66</b>
Shear strength $F_{v;Rd} =$	8675	<b>0.59</b>	Block shear $F_{u;Rd} =$	10634	<b>0.43</b>
Bearing strength $F_{b;Rd} =$	11695	<b>0.44</b>	Shear strength $F_{v;Rd} =$	8675	<b>0.53</b>
Combined effect $F_{v;Rd} =$	8675	<b>0.59</b> elastisch	Bearing strength $F_{b;Rd} =$	11825	<b>0.39</b>
			Combined effect $F_{v;Rd} =$	8675	<b>0.53</b> elastisch



Project: ZW-oost  
Mast: HC+0

**Angle check**

NEN-EN1993-1-1 and EN1993-3-1

Datum: 2021-05-17  
Auteur: TBR  
Versie: 2,9

<b>Member name</b>	<b>Group 310</b>	<b>Conclusion</b>
<b>Section</b>	<b>vDEA 120x120x12 (20)</b>	U.C. (compression) <b>0,87 &lt; 1,0 OK</b>
		U.C. (tension) <b>0,42 &lt; 1,0 OK</b>

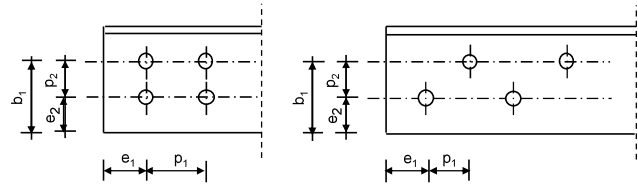
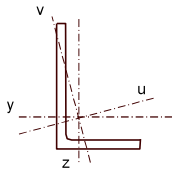

Steel grade **S355**

**Member loads**

Compressive force  $N_{Ed} =$  **690 kN**  
Tensile force **-690 kN**

**Crossing diagonal loads**

Applicable: **No**  
Min. tensile force diagonal 2 **1 kN**  
Max. comp. force diagonal 1 **1 kN**  
Position crossing diagonal y-axis **1,00 m**

**Construction loads**

Vertical construction load **1,0 kN**  
Member angle to horizontal **0 °**  
Bending around axis **y-axis**

**Geometry**

System length y-axis  $L_{y,buc} =$  **3,50 m**  
System length z-axis  $L_{z,buc} =$  **3,50 m**  
System length v-axis  $L_{v,buc} =$  **3,50 m**

Member type **Other**  
Type bracing **Non staggered**

**End conditions**

Begin **Continuous**  
End **Continuous**  
Restraint code TOWER **C4**

Aanvullende knikcontrole o.b.v. "standaard" EC-knikcontrole met knikkromme "c" voor staven met twee hoekprofielen

$N_{b,Rd,PLS} = 855 \text{ kN}$   
 $N_{b,Rd,EC} = 798 \text{ kN}$

**Results stability**

		$\lambda_{eff,rel}$	$\lambda_{eff}$	$\chi_{buc}$	$\eta$	$N_{b,Rd} = \eta \chi A f_y / \gamma_{M1}$	
$L_{y,buc} =$	3,50 m	1,25	1,25	0,41	1	798	0,87
$L_{z,buc} =$	3,50 m	1,07	1,07	0,50	1	982	0,70
$L_{v,buc} =$	3,50 m	1,24	1,24	0,41	1	810	0,85
$L_{tk,buc} =$	3,50 m	0,80		0,66	1	1292	0,53

Project: ZW-oost  
Mast: HC+0

**Angle check**

NEN-EN1993-1-1 and EN1993-3-1

Datum: 2021-05-17  
Auteur: TBR  
Versie: 2,9

<b>Member name</b>	<b>Group 311.3</b>	<b>Conclusion</b>
<b>Section</b>	<b>vDEA 150x150x12 (12)</b>	U.C. (compression) <b>0,73 &lt; 1,0 OK</b>
		U.C. (tension) <b>0,31 &lt; 1,0 OK</b>

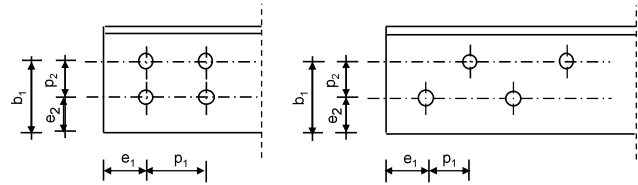
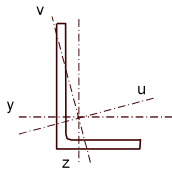

Steel grade **S355**

**Member loads**

Compressive force  $N_{Ed} =$  **510 kN**  
Tensile force **-510 kN**

**Crossing diagonal loads**

Applicable: **No**  
Min. tensile force diagonal 2 **1 kN**  
Max. comp. force diagonal 1 **1 kN**  
Position crossing diagonal y-axis **1,00 m**

**Construction loads**

Vertical construction load **1,0 kN**  
Member angle to horizontal **0 °**  
Bending around axis **y-axis**

**Geometry**

System length y-axis  $L_{y,buc} =$  **3,25 m**  
System length z-axis  $L_{z,buc} =$  **6,51 m**  
System length v-axis  $L_{v,buc} =$  **3,25 m**

Member type **Other**  
Type bracing **Non staggered**

**End conditions**

Begin **Continuous**  
End **Continuous**  
Restraint code TOWER **C4**

Aanvullende knikcontrole o.b.v. "standaard" EC-knikcontrole met knikkromme "c" voor staven met twee hoekprofielen

$N_{b,Rd,PLS} = 822\text{kN}$   
 $N_{b,Rd,EC} = 696\text{kN}$

**Results stability**

	$\lambda_{eff,rel}$	$\lambda_{eff}$	$\lambda_{eff,mod}$	$\chi_{buc}$	$\eta$	$N_{b,Rd} = \eta \chi A f_y / \gamma_{M1}$	
$L_{y,buc} =$	3,25 m	0,92	0,92	1,05	0,58	1447	<b>0,35</b>
$L_{z,buc} =$	6,51 m	1,61	1,61	1,53	0,28	696	<b>0,73</b>
$L_{v,buc} =$	3,25 m	0,92	0,92	0,99	0,59	1459	<b>0,35</b>
$L_{tk,buc} =$	3,25 m	0,77			0,68	1684	<b>0,30</b>

Project: ZW-oost  
Mast: HC+0

**Angle check**

NEN-EN1993-1-1 and EN1993-3-1

Datum: 2021-05-17  
Auteur: TBR  
Versie: 2,9

<b>Member name</b>	<b>Group 213.3</b>	<b>Conclusion</b>
<b>Section</b>	<b>vDEA 160x160x15 (24)</b>	U.C. (compression) <b>0,81 &lt; 1,0 OK</b>
		U.C. (tension) <b>0,25 &lt; 1,0 OK</b>

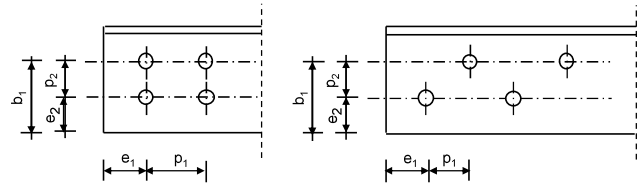
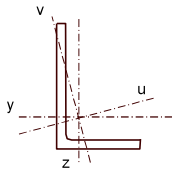

Steel grade **S355**

**Member loads**

Compressive force  $N_{Ed} =$  **420 kN**  
Tensile force **-420 kN**

**Crossing diagonal loads**

Applicable: **No**  
Min. tensile force diagonal 2 **1 kN**  
Max. comp. force diagonal 1 **1 kN**  
Position crossing diagonal y-axis **1,00 m**

**Construction loads**

Vertical construction load **1,0 kN**  
Member angle to horizontal **0 °**  
Bending around axis **y-axis**

**Geometry**

System length y-axis  $L_{y,buc} =$  **3,30 m**  
System length z-axis  $L_{z,buc} =$  **9,90 m**  
System length v-axis  $L_{v,buc} =$  **3,30 m**

Aanvullende knikcontrole o.b.v. "standaard" EC-knikcontrole met knikkromme "c" voor staven met twee hoekprofielen

$N_{b,Rd,PLS} = 704\text{kN}$   
 $N_{b,Rd,EC} = 520\text{kN}$

**Results stability**

		$\lambda_{eff,rel}$	$\lambda_{eff}$	$\chi_{buc}$	$\eta$	$N_{b,Rd} = \eta \chi A_f \sigma_y / \gamma_{M1}$	
$L_{y,buc} =$	3,30 m	0,88	0,88	0,61	1	2031	0,21
$L_{z,buc} =$	9,90 m	2,27	2,27	0,16	1	520	0,81
$L_{v,buc} =$	3,30 m	0,89	0,89	0,61	1	2010	0,21
$L_{tk,buc} =$	3,30 m	0,66		0,75	1	2484	0,17

## APPENDIX C

### Knikverkorters

---

Niet in PLS-TOWER gemodelleerde elementen in de constructie worden aanvullend getoetst. Hieronder vallen de knikverkorters van de randstijl en profielen onderdeel van stabiliteitsverbanden. De staven worden getoetst op:

- voldoende trek- of druksterkte als steunegend profiel voor randstijl, 1% van de knikcapaciteit van de randstijl;
- slankheid;
- klimbelasting

Voor de beloopbaarheid zijn staven in de traverse aanwezig. Deze zijn niet constructief (voorzien van slobgaten) en worden enkel getoetst op de klimbelasting van 1,0 kN. Zie hoofdstuk 4.2.5 en 5.7.2. van het uitgangspuntenrapport.

De knikverkorters van het bovenstuk zijn voor alle masttypen in de groep van combi-hoekmasten gelijk. Om deze reden worden alléén voor masttype HA+0/c de knikverkorters van het bovenstuk en het onderstuk getoetst. Voor de overige masttypen worden alleen de knikverkorters van het onderstuk getoetst.

Profielen uit horizontaalverbanden van het onderstuk zijn in PLS-TOWER aanwezig maar worden in deze Appendix aanvullend getoetst op buiging. Profielafmeting en boutverbinding uit PLS-TOWER is leidend.

# Overzicht knikverkorters – HA+0/c

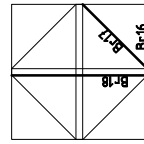
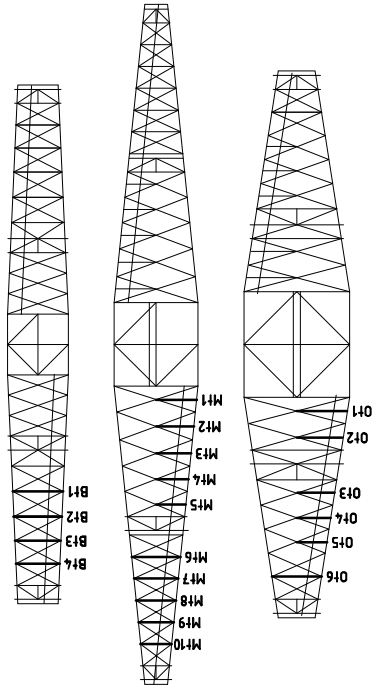

Tussenschot +15,9m

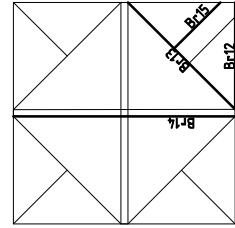

Tussenschot +6,04m

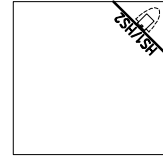

Standaard frame

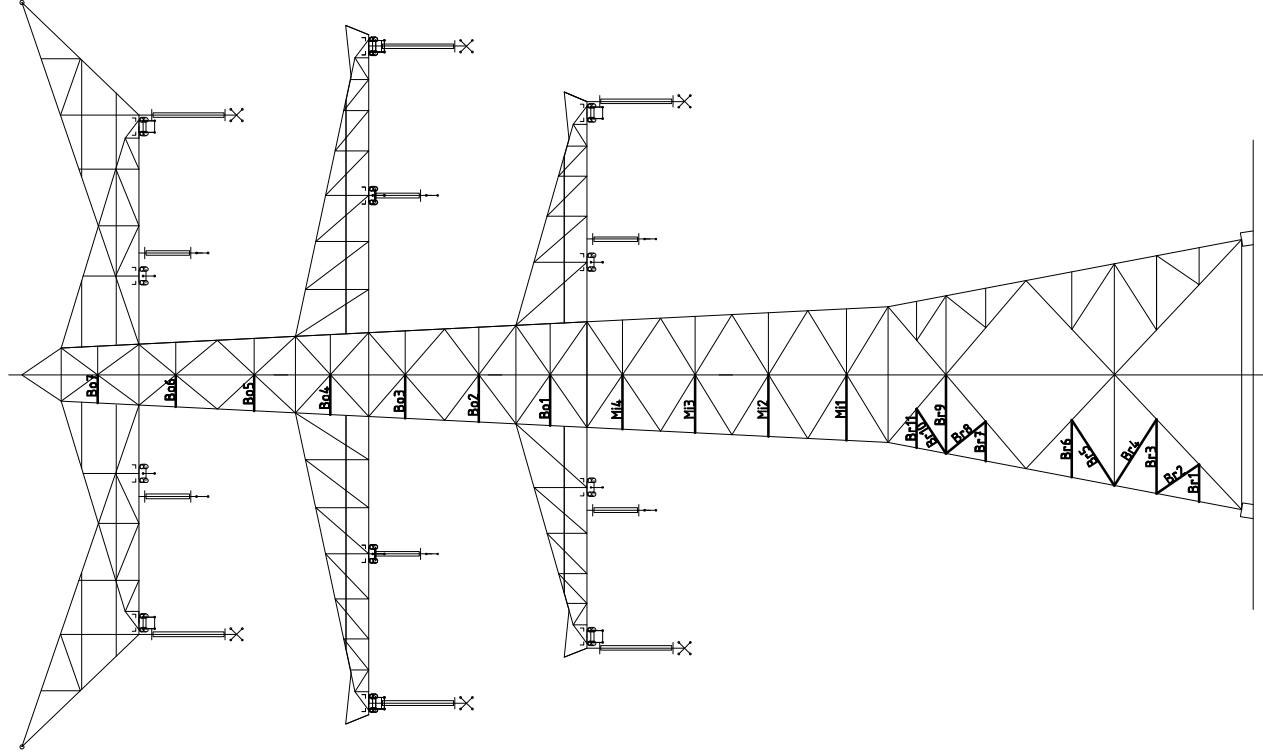



**Redundant members**

RLI-TLB  
HA+0/c

Date: 2021-07-09  
Author: MRE  
Version: 1.9

Posnr.	Section	Schematization	Profile	Steel Quality	Bolt Quality	Length (m)	Angle (°)	Slenderness	Normal Force (kN)	Moment (kNm)	Buckling Cap. (kN)	Shear Cap. Bolt (kN)	Bearing Cap. (kN)	Net Section Cap. (kN)	Moment Cap. (kNm)	Highest U.C.	Max. usage	Notes
B1	Broekstuk	Enkele staaf	L70x6	S355J0	M20	8.8	1.62	0	118	62.1	0.61	85.4	94.1	71.3	112.9	0.87	Bearing	
B2	Broekstuk	Enkele staaf	L80x6	S355J0	M20	8.8	2.24	55	142	62.1	0.00	77.3	94.1	71.3	136.4	0.68	0.87	Bearing
B3	Broekstuk	Enkele staaf	L90x8	S355J0	M20	8.8	3.23	0	183	62.1	1.21	80.6	94.1	95.0	213.2	4.34	0.77	Buckling
B4	Broekstuk	Enkele staaf	L90x8	S355J0	M20	8.8	3.41	33	194	62.1	0.00	74.2	94.1	95.0	213.2	4.34	0.84	Buckling
B5	Broekstuk	Enkele staaf	L90x8	S355J0	M20	8.8	3.40	33	193	62.1	0.00	74.5	94.1	95.0	213.2	4.34	0.83	Buckling
B6	Broekstuk	Enkele staaf	L80x6	S355J0	M20	8.8	2.50	0	159	62.1	0.94	66.6	94.1	71.3	136.4	2.68	0.93	Buckling
B7	Broekstuk	Enkele staaf	L70x6	S355J0	M20	8.8	1.72	0	125	62.1	0.64	79.3	94.1	71.3	112.9	1.99	0.87	Bearing
B8	Broekstuk	Enkele staaf	L80x6	S355J0	M20	8.8	2.23	51	141	62.1	0.00	78.0	94.1	71.3	136.4	2.68	0.87	Bearing
B9	Broekstuk	Enkele staaf	L90x8	S355J0	M20	8.8	3.43	0	195	62.1	1.29	73.6	94.1	95.0	213.2	4.34	0.84	Buckling
B10	Broekstuk	Enkele staaf	L80x6	S355J0	M20	8.8	2.32	33	148	62.1	0.44	119.0	94.1	71.3	136.4	2.68	0.87	Bearing
B11	Broekstuk	Enkele staaf	L70x6	S355J0	M20	8.8	1.17	0	86	62.1	0.00	57.4	60.3	69.7	112.9	1.99	0.87	Bearing
B12	Tussenschot +6,04m	Enkele staaf	L100x8	S355J0	M16	8.8	4.83	0	245	0.0	1.81	56.8	60.3	69.7	257.2	5.49	0.34	Bending
B13	Tussenschot +6,04m	Kruisende staaf halverwege	L100x8	S355J0	M16	8.8	6.83	0	222	0.0	2.56	56.8	60.3	69.7	257.2	7.19	0.25	Bending
B14	Tussenschot +6,04m	Enkele staaf	L70x6	S355J0	M16	8.8	3.41	0	245	0.0	1.81	57.4	60.3	69.7	122.3	7.19	0.25	Bending
B15	Tussenschot +6,04m	Enkele staaf	L130x12	S355J0	M16	8.8	2.94	0	249	0.0	1.28	29.4	60.3	52.3	122.3	1.99	0.67	Bending
B16	Tussenschot +15,9m	Enkele staaf	L90x8	S355J0	M16	8.8	4.17	0	74	0.0	1.10	380.6	60.3	104.5	620.9	17.91	0.06	Bending
B17	Tussenschot +15,9m	Enkele staaf	L90x8	S355J0	M16	8.8	5.91	0	237	0.0	1.56	54.4	60.3	69.7	225.8	4.34	0.37	Bending
B18	Tussenschot +15,9m	Kruisende staaf halverwege	L80x8	S355J0	M20	8.8	2.87	0	168	0.0	1.11	91.6	60.3	69.7	225.8	5.70	0.19	Bending
M1	Middenstuk1	Enkele staaf	L80x8	S355J0	M20	8.8	2.70	0	184	62.5	1.07	71.0	94.1	95.0	181.9	3.33	0.88	Buckling
M2	Middenstuk1	Enkele staaf	L80x6	S355J0	M20	8.8	2.53	0	161	52.2	0.95	65.3	94.1	95.0	181.9	3.33	0.80	Buckling
M3	Middenstuk2	Enkele staaf	L80x6	S355J0	M20	8.8	2.38	0	151	52.2	0.89	71.4	94.1	71.3	136.4	2.68	0.80	Buckling
M4	Middenstuk2	Enkele staaf	L70x6	S355J0	M16	8.8	2.07	0	162	28.6	0.78	62.0	60.3	52.3	122.3	1.99	0.55	Bearing
B01	Bovenstuk1	Enkele staaf	L70x6	S355J0	M16	8.8	2.22	0	151	28.6	0.83	56.3	60.3	52.3	122.3	1.99	0.55	Bearing
B02	Bovenstuk1	Enkele staaf	L60x6	S355J0	M16	8.8	1.90	0	163	28.6	0.71	47.5	60.3	52.3	98.8	1.4	0.60	Buckling
B03	Bovenstuk2	Enkele staaf	L50x5	S355J0	M16	8.8	1.74	0	179	13.6	0.65	28.8	60.3	41.3	43.1	0.8	0.83	Bending
B04	Bovenstuk2	Enkele staaf	L50x5	S355J0	M16	8.8	1.58	0	162	13.6	0.59	33.3	60.3	41.3	43.1	0.8	0.75	Bending
B05	Bovenstuk2	Enkele staaf	L50x5	S355J0	M16	8.8	1.41	0	144	13.6	0.53	39.0	60.3	41.3	43.1	0.8	0.67	Bending
B06	Bovenstuk2	Enkele staaf	L50x5	S355J0	M16	8.8	1.24	0	127	7.4	0.46	46.0	60.3	41.3	43.1	0.8	0.59	Bending
B07	Bovenstuk2	Enkele staaf	L60x6	S355J0	M16	8.8	2.19	0	187	0.0	0.82	38.9	60.3	52.3	98.8	1.4	0.60	Bending
O1	Ondertaverse	Enkele staaf	L50x5	S355J0	M16	8.8	1.97	0	203	0.0	0.74	24.0	60.3	41.3	43.1	0.8	0.94	Bending
O2	Ondertaverse	Enkele staaf	L50x5	S355J0	M16	8.8	1.61	0	166	0.0	0.60	32.0	60.3	41.3	43.1	0.8	0.77	Bending
O3	Ondertaverse	Enkele staaf	L50x5	S355J0	M16	8.8	1.31	0	151	0.0	0.55	36.7	60.3	41.3	43.1	0.8	0.70	Bending
O4	Ondertaverse	Enkele staaf	L50x5	S355J0	M16	8.8	1.47	0	135	0.0	0.49	42.6	60.3	41.3	43.1	0.8	0.63	Bending
O5	Ondertaverse	Enkele staaf	L60x6	S355J0	M16	8.8	1.76	0	185	0.0	0.81	39.5	60.3	52.3	98.8	1.4	0.60	Bending
O6	Ondertaverse	Enkele staaf	L50x5	S355J0	M16	8.8	1.78	0	182	0.0	0.67	28.0	60.3	41.3	43.1	0.8	0.85	Bending
Mk2	Middentaverse	Enkele staaf	L50x5	S355J0	M16	8.8	1.65	0	169	0.0	0.57	31.3	60.3	41.3	43.1	0.8	0.79	Bending
Mk3	Middentaverse	Enkele staaf	L50x5	S355J0	M16	8.8	1.53	0	157	0.0	0.52	34.8	60.3	41.3	43.1	0.8	0.73	Bending
Mk4	Middentaverse	Enkele staaf	L50x5	S355J0	M16	8.8	1.41	0	145	0.0	0.53	38.7	60.3	41.3	43.1	0.8	0.67	Bending
Mk5	Middentaverse	Enkele staaf	L50x5	S355J0	M16	8.8	1.29	0	133	0.0	0.48	43.5	60.3	41.3	43.1	0.8	0.62	Bending
Mk6	Middentaverse	Enkele staaf	L60x6	S355J0	M16	8.8	2.14	0	183	0.0	0.80	40.3	60.3	52.3	98.8	1.4	0.59	Bending
Mk7	Middentaverse	Enkele staaf	L50x5	S355J0	M16	8.8	1.94	0	159	0.0	0.73	24.5	60.3	41.3	43.1	0.8	0.93	Bending
Mk8	Middentaverse	Enkele staaf	L50x5	S355J0	M16	8.8	1.75	0	179	0.0	0.66	28.7	60.3	41.3	43.1	0.8	0.84	Bending
Mk9	Middentaverse	Enkele staaf	L50x5	S355J0	M16	8.8	1.55	0	160	0.0	0.58	34.0	60.3	41.3	43.1	0.8	0.74	Bending
M10	Middentaverse	Enkele staaf	L50x5	S355J0	M16	8.8	1.36	0	140	0.0	0.51	40.7	60.3	41.3	43.1	0.8	0.65	Bending
B11	Boventraverse	Enkele staaf	L60x6	S355J0	M16	8.8	2.19	0	188	0.0	0.82	38.7	60.3	52.3	98.8	1.4	0.61	Bending
B12	Boventraverse	Enkele staaf	L60x6	S355J0	M16	8.8	2.09	0	179	0.0	0.78	41.5	60.3	52.3	98.8	1.4	0.58	Bending



**Redundant members**

RLL-TLB  
HA+0/c

Date: 2021-07-09  
Author: MRE  
Version: 1.9

Posnr.	Section	Schematization	Profile	Steel Quality	Bolt	Quality	Length (m)	Angle (°)	Slender ness	Normal Force (kN)	Moment (kNm)	Buckling Cap. (kN)	Shear Cap. Bolt (kN)	Bearing Cap. (kN)	Net Section Cap. (kN)	Moment Cap. (kNm)	Highest U.C.	Max. usage	Notes
B3	Boventraverse	Enkele staaf	L50x5	S355/0	M16	8.8	2.00	0	205	0.0	0.75	23.4	60.3	41.3	43.1	0.8	0.96	Bending	
B4	Boventraverse	Enkele staaf	L50x5	S355/0	M16	8.8	1.91	0	196	0.0	0.72	25.1	60.3	41.3	43.1	0.8	0.93	Bending	
HS1	High Step	Enkele staaf	L80x6	S355/0	M16	8.8	3.25	0	207	0.0	2.44	45.2	60.3	52.3	145.8	2.7	0.95	Bending	
HS2	High Step	Enkele staaf	L70x7	S355/0	M16	8.8	2.80	0	205	0.0	2.10	46.0	60.3	61.0	142.7	2.2	0.97	Bending	

# Overzicht knikverkorters – HA+3/c

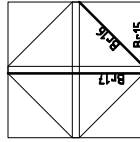
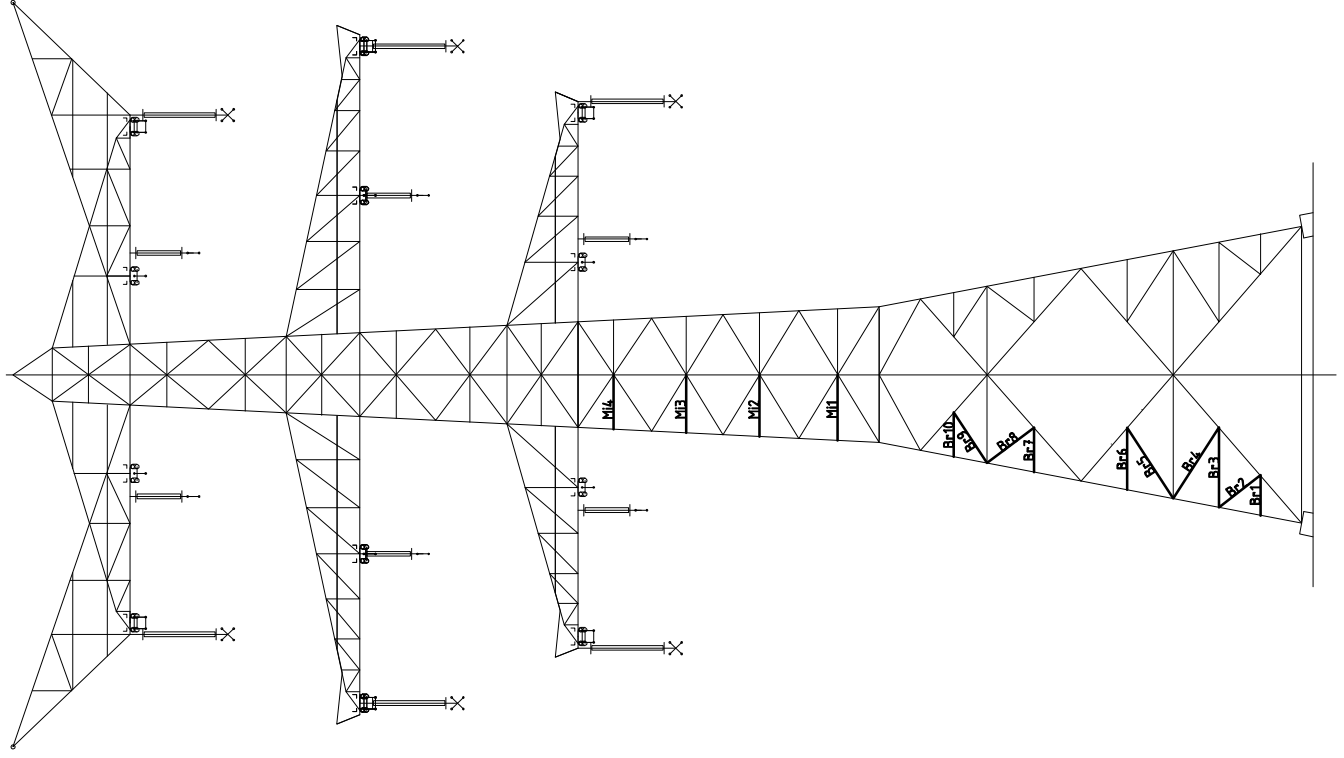

Tussenschot +18,9m

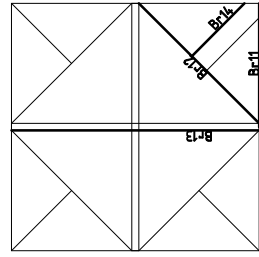

Tussenschot +6,09m





## Redundant members

Date: 2021-07-09  
 Author: MRE  
 Version: 1.9

RLI-TLB  
 HA+3/c

Posnr.	Section	Schematization	Profile	Steel Quality	Bolt Quality	Length (m)	Angle (°)	Slenderness	Normal Force (kN)	Moment (kNm)	Buckling Cap. (kN)	Shear Cap. Bolt (kN)	Bearing Cap. (kN)	Net Section Cap. (kN)	Moment Cap. (kNm)	Highest U.C.	Max. usage	Notes
Br1	Broekstuk	Enkele staaf	L70x6	S355J0	M20	8.8	1.76	0	61.9	0.66	76.9	94.1	71.3	112.9	1.99	0.87	Bearing	
Br2	Broekstuk	Enkele staaf	L80x6	S355J0	M20	8.8	2.28	52	145	1.30	75.5	94.1	71.3	136.4	2.68	0.87	Bearing	
Br3	Broekstuk	Enkele staaf	L90x8	S355J0	M20	8.8	3.47	0	197	1.30	72.3	94.1	95.0	213.2	4.34	0.86	Buckling	
Br4	Broekstuk	Enkele staaf	L90x8	S355J0	M20	8.8	3.68	30	209	1.20	66.1	94.1	95.0	213.2	4.34	0.94	Buckling	
Br5	Broekstuk	Enkele staaf	L90x8	S355J0	M20	8.8	3.67	30	208	1.19	66.4	94.1	95.0	213.2	4.34	0.93	Buckling	
Br6	Broekstuk	Enkele staaf	L80x8	S355J0	M20	8.8	2.70	0	173	1.01	77.4	94.1	95.0	181.9	3.33	0.80	Buckling	
Br7	Broekstuk	Enkele staaf	L70x6	S355J0	M20	8.8	1.93	0	141	0.72	68.3	94.1	71.3	112.9	1.99	0.91	Buckling	
Br8	Broekstuk	Enkele staaf	L80x6	S355J0	M20	8.8	2.56	53	163	0.72	64.3	94.1	71.3	136.4	2.68	0.96	Buckling	
Br9	Broekstuk	Enkele staaf	L80x6	S355J0	M20	8.8	2.64	30	169	0.86	80.0	94.1	95.0	181.9	3.33	0.77	Buckling	
Br10	Broekstuk	Enkele staaf	L70x6	S355J0	M20	8.8	1.93	0	141	0.72	68.3	94.1	71.3	112.9	1.99	0.91	Buckling	
Br11	Tussenschot +6,09m	Enkele staaf	L110x10	S355J0	M20	8.8	5.39	0	250	2.02	75.9	94.1	118.8	345.0	8.04	0.26	Bending	
Br12	Tussenschot +6,09m	Kniksteun op 0,5L	L100x8	S355J0	M16	8.8	7.41	0	241	0.0	50.3	60.3	69.7	257.2	7.19	0.39	Bending	
Br13	Tussenschot +6,09m	Kruisende staaf halverwege	L110x10	S355J0	M16	8.8	10.78	0	250	2.02	75.9	60.3	87.1	360.6	10.69	0.19	Bending	
Br14	Tussenschot +6,09m	Enkele staaf	L80x6	S355J0	M16	8.8	3.70	0	235	0.0	36.9	60.3	52.3	145.8	2.68	0.54	Bending	
Br15	Tussenschot +18,9m	Kniksteun op 0,5L	L130x12	S355J0	M20	8.8	2.95	0	74	1.11	379.8	94.1	142.5	602.1	17.91	0.06	Bending	
Br16	Tussenschot +18,9m	Enkele staaf	L90x8	S355J0	M16	8.8	3.97	0	225	0.0	58.8	60.3	69.7	225.8	4.34	0.36	Bending	
Br17	Tussenschot +18,9m	Kruisende staaf halverwege	L90x8	S355J0	M16	8.8	5.91	0	168	1.11	91.6	60.3	69.7	225.8	5.70	0.19	Bending	
M11	Middenstuk1	Enkele staaf	L80x8	S355J0	M20	8.8	2.87	0	184	1.07	71.0	94.1	95.0	181.9	3.33	0.88	Buckling	
M12	Middenstuk2	Enkele staaf	L80x8	S355J0	M20	8.8	2.70	0	173	1.01	77.6	94.1	95.0	181.9	3.33	0.80	Buckling	
M13	Middenstuk2	Enkele staaf	L80x6	S355J0	M20	8.8	2.53	0	161	0.95	65.3	94.1	71.3	136.4	2.68	0.80	Buckling	
M14	Middenstuk2	Enkele staaf	L80x6	S355J0	M20	8.8	2.38	0	151	0.89	71.4	94.1	71.3	136.4	2.68	0.73	Bearing	

# Overzicht knikverkorters – HA+6/c

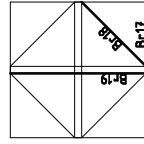
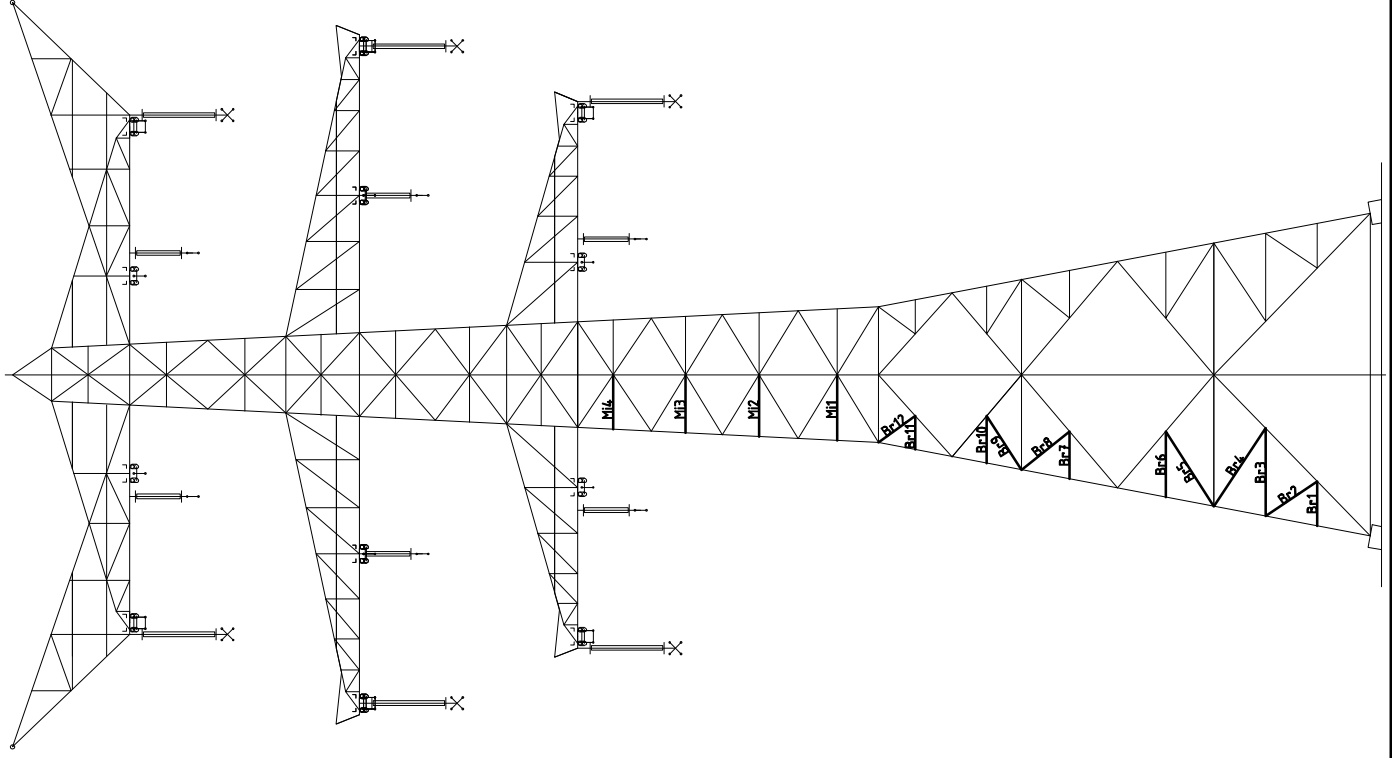

Tussenschot +21,9m

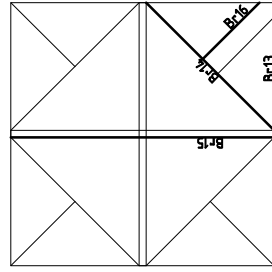

Tussenschot +7,3m



**Redundant members**

RLL-TLB  
HA+6/c

Date: 2021-07-09  
Author: MRE  
Version: 1.9

Posnr.	Section	Schematization	Profile	Steel Quality	Bolt Quality	Length (m)	Angle (°)	Slenderness	Normal Force (kN)	Moment (kNm)	Buckling Cap. (kN)	Shear Cap. Bolt (kN)	Bearing Cap. (kN)	Net Section Cap. (kN)	Moment Cap. (kNm)	Highest U.C.	Max. usage	Notes
Br1	Broekstuk	Enkele staaf	L70x6	S355J0	M20	8.8	1.94	0	141	61.5	0.73	67.8	94.1	71.3	112.9	1.99	0.91	Buckling
Br2	Broekstuk	Enkele staaf	L80x8	S355J0	M20	8.8	2.71	56	174	61.5	0.00	77.0	94.1	95.0	181.9	3.33	0.80	Buckling
Br3	Broekstuk	Enkele staaf	L90x9	S355J0	M20	8.8	3.83	0	218	1.44	1.44	69.0	94.1	106.9	239.9	4.73	0.89	Buckling
Br4	Broekstuk	Enkele staaf	L100x10	S355J0	M20	8.8	4.08	30	209	61.5	1.33	91.4	94.1	118.8	305.8	6.49	0.67	Buckling
Br5	Broekstuk	Enkele staaf	L90x9	S355J0	M20	8.8	3.88	30	221	61.5	1.26	67.6	94.1	106.9	239.9	4.73	0.91	Buckling
Br6	Broekstuk	Enkele staaf	L80x8	S355J0	M20	8.8	2.86	0	183	61.5	1.07	71.2	94.1	95.0	181.9	3.33	0.86	Buckling
Br7	Broekstuk	Enkele staaf	L80x6	S355J0	M20	8.8	2.07	0	132	61.5	0.78	85.6	94.1	71.3	136.4	2.68	0.86	Bearing
Br8	Broekstuk	Enkele staaf	L80x8	S355J0	M20	8.8	2.68	51	172	61.5	0.00	78.3	94.1	95.0	181.9	3.33	0.79	Buckling
Br9	Broekstuk	Enkele staaf	L80x8	S355J0	M20	8.8	2.80	30	180	61.5	0.91	73.4	94.1	83.2	181.9	3.33	0.84	Buckling
Br10	Broekstuk	Enkele staaf	L70x7	S355J0	M20	8.8	2.07	0	152	61.5	0.78	71.3	94.1	95.0	131.7	2.23	0.86	Buckling
Br11	Broekstuk	Enkele staaf	L60x6	S355J0	M20	8.8	1.48	0	127	61.5	0.56	66.4	94.1	64.7	65.9	1.40	0.94	Bearing
Br12	Broekstuk	Enkele staaf	L70x6	S355J0	M20	8.8	1.98	54	144	61.5	0.00	66.0	94.1	71.3	112.9	1.99	0.93	Buckling
Br13	Tussenschot + 7,3m	Enkele staaf	L120x10	S355J0	M16	8.8	5.73	0	241	0.0	2.15	88.1	60.3	87.1	395.8	9.77	0.23	Bending
Br14	Tussenschot + 7,3m	Kniksteun op 0,5l	L110x10	S355J0	M16	8.8	7.89	0	235	0.0	2.96	71.2	60.3	87.1	360.6	10.69	0.28	Bending
Br15	Tussenschot + 7,3m	Kruisende staaf halverwege	L120x10	S355J0	M16	8.8	11.46	0	241	0.0	2.15	88.1	60.3	87.1	395.8	12.83	0.17	Bending
Br16	Tussenschot + 7,3m	Enkele staaf	L90x8	S355J0	M16	8.8	3.94	0	224	0.0	1.48	59.5	60.3	69.7	225.8	4.34	0.35	Bending
Br17	Tussenschot + 21,9m	Kniksteun op 0,5l	L130x12	S355J0	M20	8.8	2.96	0	75	0.0	1.11	378.8	94.1	142.5	602.1	17.91	0.06	Bending
Br18	Tussenschot + 21,9m	Enkele staaf	L90x8	S355J0	M16	8.8	3.97	0	225	0.0	1.49	58.8	60.3	69.7	225.8	4.34	0.36	Bending
Br19	Tussenschot + 21,9m	Kruisende staaf halverwege	L90x8	S355J0	M16	8.8	5.91	0	168	0.0	1.11	91.6	60.3	69.7	225.8	5.70	0.19	Bending
M1	Middenstuk1	Enkele staaf	L80x8	S355J0	M20	8.8	2.87	0	184	62.5	1.07	71.0	94.1	95.0	181.9	3.33	0.88	Buckling
M2	Middenstuk1	Enkele staaf	L80x8	S355J0	M20	8.8	2.70	0	173	62.5	1.01	77.6	94.1	95.0	181.9	3.33	0.80	Buckling
M3	Middenstuk2	Enkele staaf	L80x6	S355J0	M20	8.8	2.53	0	161	52.2	0.95	65.3	94.1	71.3	136.4	2.68	0.80	Buckling
M4	Middenstuk2	Enkele staaf	L80x6	S355J0	M20	8.8	2.38	0	151	52.2	0.89	71.4	94.1	71.3	136.4	2.68	0.73	Bearing



## **APPENDIX D**

### **Blokdeuvels**

---



Het uitgangspunt voor de berekening van de ingestorte rand met blokdeuvels zijn de belastingen op de fundatie uit de uitvoer van het geleiderbelastingprogramma van DNV. De belastingen in de richting van de randstijl zijn van toepassing. In de tabellen is dit opgenomen in de laatste kolom  $R_{z,lok}$ . De controles zijn uitgevoerd met een spreadsheet. Vanwege de helling van de drukdiagonaal wordt per krachtrichting bepaald hoeveel deuvels effectief zijn, hierdoor is het aantal ingevoerde deuvels in de berekening kleiner dan het aantal deuvels op de principetekening.

Er wordt voor gekozen om de blokdeuvels universeel uit te werken op basis van het profiel van de randstijl, dit betreft een XEA250x250x24-profiel en heeft betrekking op de volgende masttypen:

- Masttype HA+0/c, HA+0/ci, HA+3/c, HA+3/ca en HA+6/c;
- Masttype HB+0/c en HB+6/c;
- Masttype HC+0/c;
- Masttype WA+0/c en WA+6/c;
- Masttype WB+0/c;
- Masttype EA-3/co.

De blokdeuvels worden getoetst op de maatgevende belasting van bovenstaande masttypen. De belasting is opgenomen in Appendix A van het betreffende masttype, masttype HC+0/c is maatgevend. De optredende belastingen van masttype HC+0/c zijn 5503kN (druk) en -4739kN (trek), deze worden ruim naar boven afgerond op **5600kN** (druk) en **-4800kN** (trek). Met deze belastingen worden alle masttypen geborgd en hebben eventuele kleine aanpassingen geen invloed op deze uitwerking.

# Principe blokdeuvels - combi-hoek-, combi-wissel en combi-eindmasten

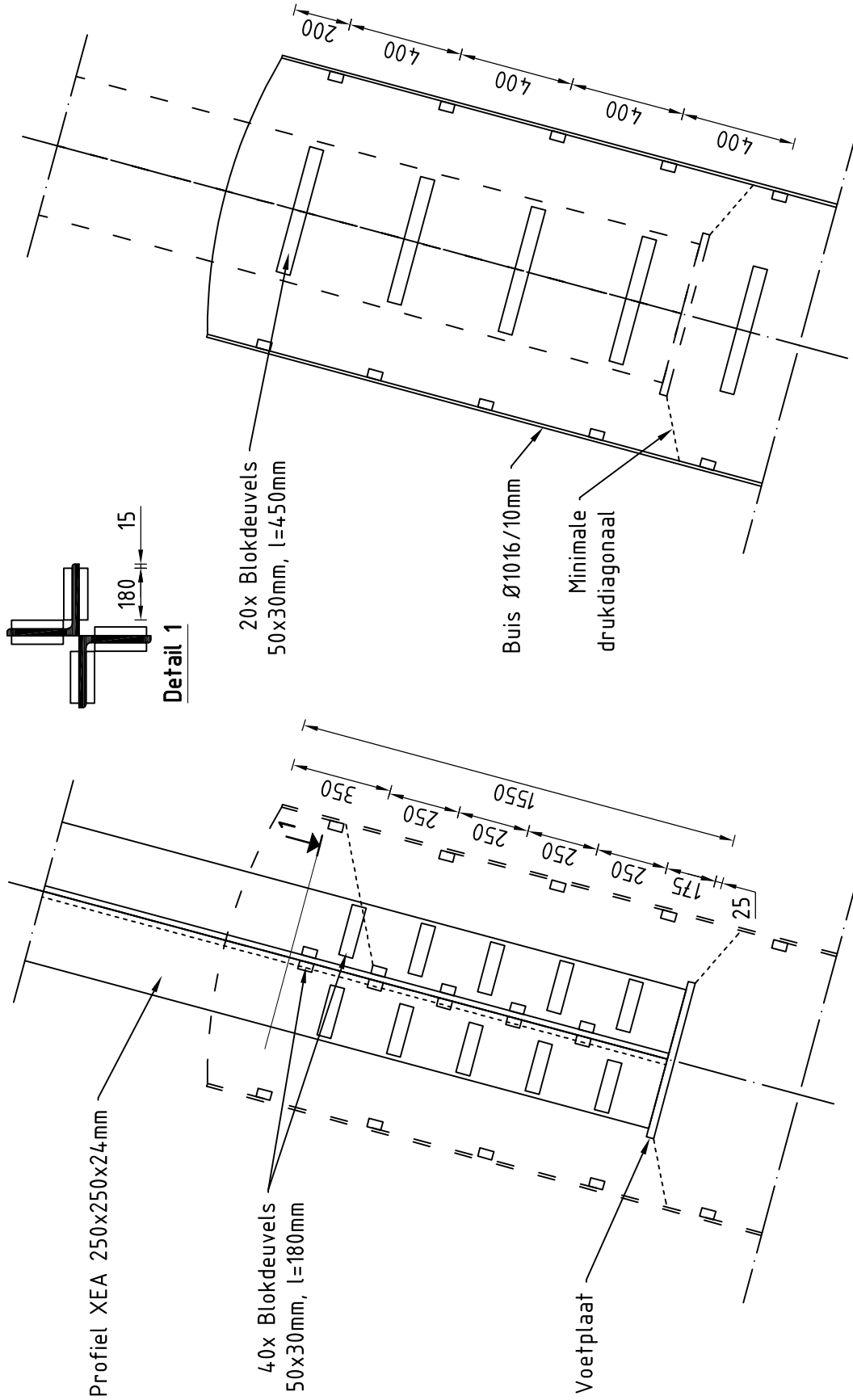

## Algemene opmerkingen

- Aarding niet aangegeven
- Spiraalwapening niet aangegeven

Project: RLL-TBG  
 Mast: HA-B-C/c & WA-B/c & EA-co

**Shear blocks**

NEN-EN 1993-1-1 en NEN-EN 1994-1-1

Datum: 2021-07-09

Auteur: TBR

Versie: 1.5

Load			Results		
Compression	$F_{Ed,c}$	5600 kN	Compression	U.C.	0.87 < 1,00 OK
Tension	$F_{Ed,t}$	4800 kN	Tension	U.C.	0.78 < 1,00 OK

**Main leg**

Profile		<b>XEA 250x250x24</b>
Type		Double (XEA)
Steel material		S355
Cross section		22934 mm <sup>2</sup>
Axial capacity	$N_{pl}$	8142 kN
Width	b	500 mm
Thickness	t	24 mm
Length in concrete		1550 mm

**Capacity shear blocks main leg**

$A_{f1} = A_{f1,out} + A_{f1,in} =$	10800 mm <sup>2</sup>
$A_{f2} = A_{f2,out} + A_{f2,in} =$	31807.5 mm <sup>2</sup>
Slope	1 : 5
$C_A = \sqrt{(A_{f2}/A_{f1})} =$	1.72
$f_{jd} = C_A \times f_{cd} =$	25.8 N/mm <sup>2</sup>
$F_{Rd,c} = n_c \times A_{f1} \times f_{jd} =$	4459 kN
$F_{Rd,t} = n_t \times A_{f1} \times f_{jd} =$	4459 kN

**Shear blocks main leg**

Sides		2
Width	b	50 mm
Thickness	h	30 mm
Length - outside	$L_{out}$	180 mm
Length - inside	$L_{in}$	180 mm
Eccentricity	e	15 mm
Welds	a	5 mm
c.t.c. separation	s	250 mm
Number for compr.	$n_c$	16 -
Number for tension	$n_t$	16 -

**Capacity foot plate**

$k_d =$	1.73 -
$f_{jd} = C_A \times f_{cd} =$	26.0 N/mm <sup>2</sup>
$c = t\sqrt{(f_{yd} / 3f_{jd})} =$	53 mm
$m^* = \min(c, m) =$	30 mm
Type foot plate	Extending
Effective for	Compr. and tension
$A_{p,c} =$	86534 mm <sup>2</sup>
$F_{Rd,c} = A_{p,druk} \times f_{jd} =$	2254 kN
$A_{p,t} =$	63600 mm <sup>2</sup>
$F_{Rd,t} = A_{p,t} \times f_{jd} =$	1657 kN

**Foot plate**

Thickness	t	25 mm
Ext. length	m	30 mm
Welds	a	5 mm

**Capacities**

$F_{rd,c,plate} =$	2254 kN
$F_{rd,blocks,c} =$	4459 kN
$F_{rd,c} = F_{rd,blk} + F_{rd,footplate} =$	<b>6713 kN</b>
U.C. compression	0.83 < 1,00 OK
Welds foot plate (see next page)	2454 kN
$F_{rd,t} = \min. (\text{welds} / \text{foot plate}) =$	1657 kN
$F_{rd,blocks,t} =$	4459 kN
$F_{rd,t} = F_{rd,blk} + F_{rd,footplate} =$	<b>6116 kN</b>
U.C. tension	0.78 < 1,00 OK
U.C. welds	0.47 < 1,00 OK

**Pile**

Name		Buispaal
Diameter		1016 mm
Thickness		10 mm
Cross section		31604 mm <sup>2</sup>
Steel material		S355
Capacity		11220 kN
Concrete strength		C30/37

**Shear blocks pile**

Width	b	50 mm
Thickness	h	30 mm
Length	L	450 mm
Welds	a	5 mm
c.t.c. separation	s	400 mm
Number for compr.	$n_c$	16 -
Number for tension	$n_t$	16 -
Blocks per row	$n_{bl}$	4 -
Effectivity of total	$C_{red}$	100% -

**Capacity shear blocks pile**

$A_{f1} =$	13500 mm <sup>2</sup>
$A_{f2} =$	53076 mm <sup>2</sup>
$C_A = \sqrt{(A_{f2}/A_{f1})} =$	1.98 -
$f_{jd} = k_d \times f_{cd} =$	29.8 N/mm <sup>2</sup>
$F_{Rd,c} = n_c \times A_{f1} \times f_{jd} \times C_{red} =$	<b>6440 kN</b>
U.C. compression	0.87 < 1,00 OK
$F_{Rd,t} = n_t \times A_{f1} \times f_{jd} \times C_{red} =$	<b>6440 kN</b>
U.C. tension	0.75 < 1,00 OK
U.C. welds	0.45 < 1,00 OK

**Design value concrete strength**

Material factor	$\gamma_c$	1.5
Add. mat. factor	$\gamma_m$	1.33 -
$f_{cd} =$		15.0 N/mm <sup>2</sup>

**"Splitting" of pile**

Spread of forces		45 °
Length force flow		1052 mm
Splitting force		2281 kN/m
Yield strength wall	$f_{yd} =$	355 N/mm <sup>2</sup>
Capacity tubular pile		7100 kN/m
U.C.		0.32 < 1,00 OK

**Steel tower stub**

Yield strength	$f_{yd} =$	355 N/mm <sup>2</sup>
Tensile strength	$f_{ud} =$	490 N/mm <sup>2</sup>

Project: RLL-TBG  
 Mast: HA-B-C/c & WA-B/c & EA-co

### Welds of shear blocks of main leg

Out-of-plane loading

#### Plate

t = 50 mm  
 Grade S355  
 $f_{yd} = 355 \text{ N/mm}^2$   
 $f_u = 490 \text{ N/mm}^2$

#### Member forces

Factor 1.2  
 $F_{t,Ed} = 0 \text{ kN}$   
 $F_{v,Ed} = F_{rd,c} / n = 334 \text{ kN}$   
 $F_{v//,Ed} = 0 \text{ kN}$   
 $M_{Ed} = 1/2 b / h \times F_{v,Ed} = 5.02 \text{ kNm}$

#### Check

$\sigma_{w,Ed} = 203 \text{ N/mm}^2 \leq$   
 $\sigma_1 = 102 \text{ N/mm}^2 \leq$

#### Welds

a = 5 mm  
 l = 360 mm  
 $\beta_w = 0.9 -$   
 $\gamma_{M2} = 1.25 -$

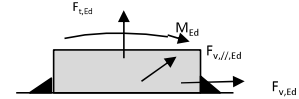

#### Stress components

$\sigma_1 = \tau_1 = F_{t,Ed} \sqrt{2} / 4al = 0 \text{ N/mm}^2$   
 $\sigma_1 = \tau_1 = F_{v,Ed} \sqrt{2} / 4al = 66 \text{ N/mm}^2$   

---

 $66 \text{ N/mm}^2$   
 $b^* = b + 2/3av^2 = 54.7 \text{ mm}$   
 $\sigma_1 = \tau_1 = 0.706M_{Ed} / al b^* = 36 \text{ N/mm}^2$   
 $\tau_{//} = F_{v//,Ed} / 2al = 0 \text{ N/mm}^2$   
 $\sigma_{w,Ed} = \sqrt{(\sigma_1^2 + 3\tau_1^2 + 3\tau_{//}^2)} = 203 \text{ N/mm}^2$

$f_u / \beta_w \gamma_{M2} = 436 \text{ N/mm}^2$  U.C. = **0.47 OK**  
 $0.9f_u / \gamma_{M2} = 353 \text{ N/mm}^2$  U.C. = **0.29 OK**

### Welds of shear blocks of pile

Out-of-plane loading

#### Plate

t = 50 mm  
 Grade S355  
 $f_{yd} = 355 \text{ N/mm}^2$   
 $f_u = 490 \text{ N/mm}^2$

#### Member forces

Factor 1.2  
 $F_{t,Ed} = 1/2 b / h \times F_{v,Ed} = 145 \text{ kN}$   
 $F_{v,Ed} = 483 \text{ kN}$   
 $F_{v//,Ed} = 0 \text{ kN}$   
 $M_{Ed} = 0.00 \text{ kNm}$

#### Check

$\sigma_{w,Ed} = 197 \text{ N/mm}^2 \leq$   
 $\sigma_1 = 99 \text{ N/mm}^2 \leq$

#### Welds

a = 5 mm  
 l = 450 mm  
 $\beta_w = 0.9 -$   
 $\gamma_{M2} = 1.25 -$

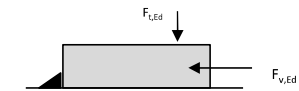

#### Stress components

$\sigma_1 = \tau_1 = F_{t,Ed} \sqrt{2} / 2al = 23 \text{ N/mm}^2$   
 $\sigma_1 = \tau_1 = F_{v,Ed} \sqrt{2} / 2al = 76 \text{ N/mm}^2$   

---

 $76 \text{ N/mm}^2$   
 $\tau_{//} = F_{v//,Ed} / 2al = 0 \text{ N/mm}^2$   
 $\sigma_{w,Ed} = \sqrt{(\sigma_1^2 + 3\tau_1^2 + 3\tau_{//}^2)} = 197 \text{ N/mm}^2$

$f_u / \beta_w \gamma_{M2} = 436 \text{ N/mm}^2$  U.C. = **0.45 OK**  
 $0.9f_u / \gamma_{M2} = 353 \text{ N/mm}^2$  U.C. = **0.28 OK**

### Welds of foot plate

$f_u / \beta_w \gamma_{M2} = 436 \text{ N/mm}^2$   
 Weld size a = 5 mm  
 Length l = 2b + 2b - t = 1952 mm  
 Capacity  $F_{Rd} = a \times l \times f_{w,d} / \sqrt{3} = 2454 \text{ kN}$





## **APPENDIX E**

### **Liggers**

---

## 1 BEREKENING OPHANGING POSTISOLATOREN

De volgende onderdelen worden berekend:

- De belastingen op de ophanging van de postisolatoren door wind en eigen gewicht;
- De dimensionering van de ophangconstructies.

Onderstaand zijn de optredende belastingen geschematiseerd:

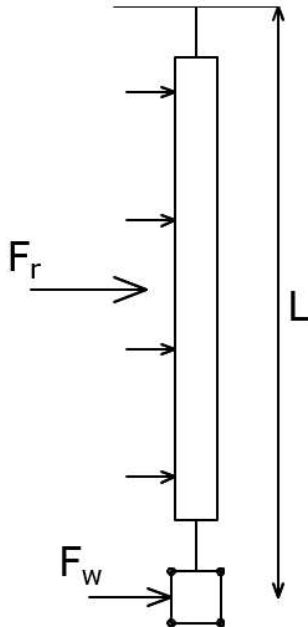

Figuur 1 Belastingeschema

### 1.1 Uitgangspunten & afmetingen postisolatoren

Voor het berekenen van de liggers voor de ophanging van de postisolatoren in de mastkoppen van de HA-masten wordt één berekening gemaakt met de volgende uitgangspunten:

- Windgebied II;
  - Windhoogte 54,5m (gebaseerd op hoogste mast HA+6/c);
  - Onbebouwd;
- Referentieperiode 50 jaar;
- Belastingfactor 1,5.

De volgende factoren worden gehanteerd:

- Krachtcoëfficiënt 1,2 voor isolatoren
- Constructiefactor geleider 1,0;
- Krachtcoëfficiënt geleider 1,0;
- Constructiefactor geleider 1,0.

Conform het uitgangspuntendocument zijn de afmetingen als volgt:

**Tabel 1 Gegevens postisolatoren**

Omschrijving	Ophanging	Gewicht [kN]	Lengte [m]	Windopp. [m]
Fasegeleider 380 kV	Bretelfixatie	2,0	4,5	1,0
Fasegeleider 150 kV	Bretelfixatie	1,5	2,7	0,7

De diameter van de geleiders is 32mm.

## 1.2 Belastingen

De extreme stuwdruk  $q_{p(z)}$  in windgebied II op een hoogte van 54,5m is 1,41kN/m<sup>2</sup>.

Er komen drie varianten voor:

1. 380 kV geleider met één postisolator;
  - Lengte geleider aan postisolator ca. 9 m;
2. 150 kV geleider met één postisolator;
  - Lengte geleider aan postisolator ca. 7 m;
3. 150 kV geleider met twee postisolatoren;
  - Lengte geleider aan postisolator ca. 3,5 m.

In het horizontale vlak bestaat er een afstand tussen het uiteinde van de afspanketting en de postisolator (zie figuur 2). Dit veroorzaakt een extra horizontale kracht vanuit de bretelle op de onderzijde van de postisolator (zie figuur 3). Het gewicht van de bretelle (380kV) is gelijk aan  $(4 \times 17,7\text{N/m} =) 70,8\text{N/m}$ . De horizontale kracht evenwijdig aan de brettelle is gelijk aan:

- $F_{h,evenw} = 1/8 \cdot q \cdot L^2 / u = 1/8 \cdot 0,0708\text{kN/m} \cdot (7,62\text{m})^2 / 1,2\text{m} = 0,4 \text{ kN}.$

De horizontale kracht loodrecht op de postisolator is gelijk aan:

- $F_{h,gel} = 2 \cdot 0,4\text{kN} \cdot 3,75\text{m} / 7,62\text{m} = 0,4 \text{ kN}.$

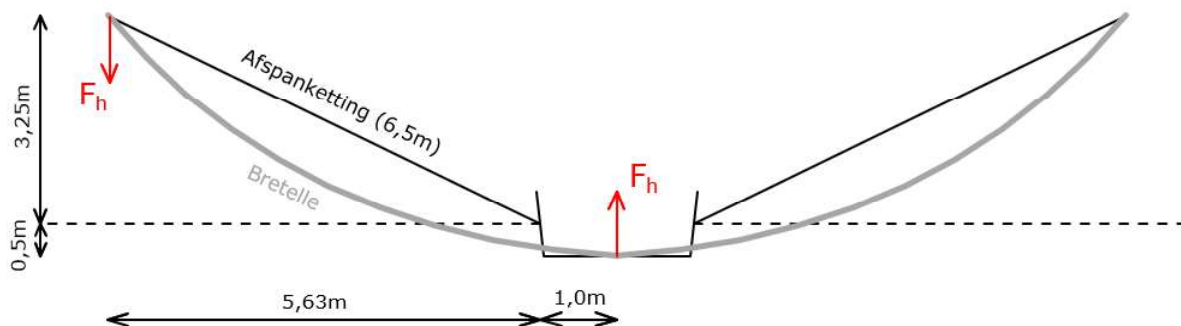

**Figuur 2 Bovenaanzicht bretelle**

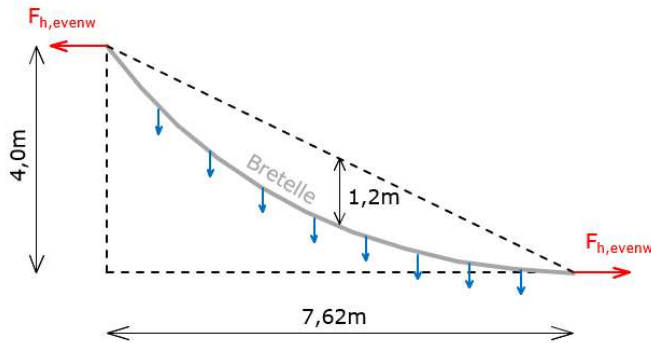

Figuur 3 Zij-aanzicht bretelle

Voor het 180kV-circuit wordt dezelfde berekening gemaakt. De afspanketting heeft een lengte van 4,0m en de tussen afstand is 2 x 2m (i.p.v. 2 x 1m). De postisolator hangt 1,0m naar buiten en de horizontale afstand (ten gevolge van de hoek) is gelijk aan  $(\sin(30^\circ) \cdot 4m) = 2m$ . De lengte is dan gelijk aan  $(\sqrt{(\cos(30^\circ) \cdot 4m + 2m)^2 + (2m + 1m)^2}) = 6,23m$ . De krachten zijn dan gelijk aan:

- $F_{h,evenw} = \frac{1}{8} \cdot q \cdot L^2 / u = 1/8 \cdot 0,0354kN/m \cdot (6,23m)^2 / 0,8m = 0,2 \text{ kN};$
- $F_{h,gel} = 2 \cdot 0,4kN \cdot 3,0m / 6,23m = 0,2 \text{ kN}.$

Belasting bij wind loodrecht op de geleider

Voor elke variant zijn in onderstaande tabellen de optredende reactiekrachten ( $F_h$ ,  $F_{v,tot}$  en  $M_{tot}$ ) op het ophangpunt van de postisolator berekend.

Tabel 2 Optredende belastingen per variant – wind loodrecht

Var.	$q_p(z)$ [kN/m <sup>2</sup> ]	$G_{post}$ [kN]	$L_{post}$ [m]	Opp [m <sup>2</sup> ]	$n_{gel}$ [n]	$\emptyset_{gel}$ [m]	$G_{gel}$ [kN/m]	$L_{gel}$ [m]	$F_{h,gel}$ [kN]
1	1,41	2	4,5	1	4	0,032	0,0177	9	0,4
2	1,41	1,5	2,7	0,7	2	0,032	0,0177	7	0,2
3	1,41	1,5	2,7	0,7	2	0,032	0,0177	3,5	0,1

Var.	$C_{f,r}$ [-]	$S_r$ [-]	$F_{r,k}$ [kN]	$M_{r,k}$ [kNm]	$C_{f,w}$ [-]	$S_w$ [-]	$F_{w,k}$ [kN]	$M_{w,k}$ [kNm]
1	1,2	1	1,69	3,81	1	1	1,62	7,31
2	1,2	1	1,18	1,60	1	1	0,63	1,71
3	1,2	1	1,18	1,60	1	1	0,32	0,85

Var.	$\gamma$ [-]	$F_{v,Ed}$ [kN]	$F_{h,tot,Ed}$ [kN]	$M_{tot,Ed}$ [kNm]
1	1,5	4,0	5,6	19,4
2	1,5	2,6	3,0	5,8
3	1,5	2,4	2,4	4,1

Belasting bij wind evenwijdig aan de geleider

Waar relevant wordt er ook getoetst aan wind evenwijdig aan de geleider. In onderstaande tabel zijn de optredende krachten weergegeven.

**Tabel 3 Optredende belastingen per variant – wind evenwijdig**

Var.	L <sub>post</sub> [m]	F <sub>h,gel</sub> [kN]	M <sub>r,-,k</sub> [kNm]	F <sub>r,k</sub> [kN]	M <sub>r,/,k</sub> [kNm]	F <sub>v,Ed</sub> [kN]	F <sub>h,-,Ed</sub> [kN]	M <sub>r,-,Ed</sub> [kNm]	F <sub>h,/,Ed</sub> [kN]	M <sub>r,/,Ed</sub> [kNm]
1	4,5	0,4	1,8	1,69	3,81	4,0	0,6	2,7	2,5	5,7
2	2,7	0,2	0,54	1,18	1,60	2,6	0,3	0,8	1,8	2,4
3	2,7	0,1	0,27	1,18	1,60	2,4	0,2	0,4	1,8	2,4

## 2 VARIANT 1 – 380 KV – 1 POSTISOLATOR

De ophanging van de postisolator bij variant 1 kent twee varianten:

- A. Ophanging aan enkele ligger (onderstaand links);
- B. Ophanging aan frame (onderstaand rechts).

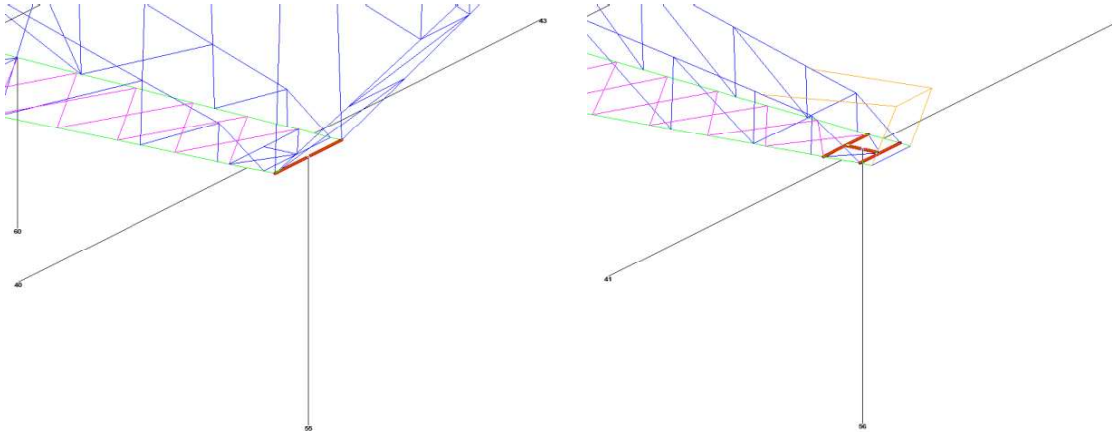

**Figuur 4** Principe ophanging variant 1A (links) en 1B (rechts)

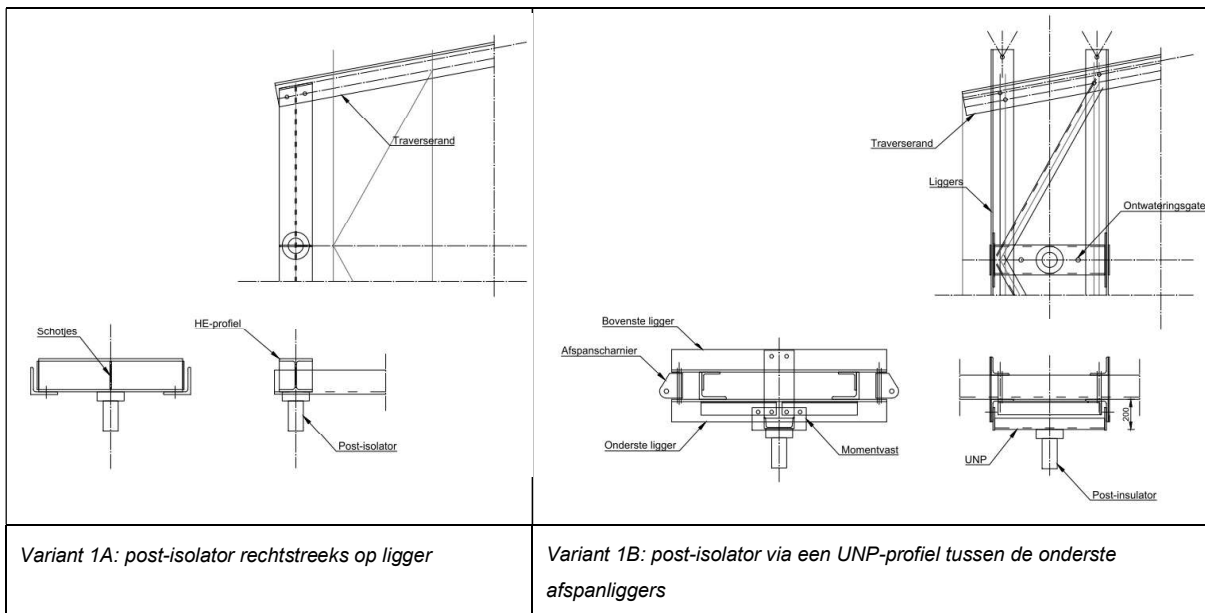

**Figuur 5** Principedetails voor bevestiging post-insulator variant 1A en 1B

## 2.1 Variant A

De postisolator wordt opgehangen aan een enkele stalen ligger. Deze ligger wordt daardoor in twee richtingen en op torsie belast. De optredende belastingen zijn:

- Verticaal  $F_v$  4,0 kN;
- Horizontaal  $F_{h,tot}$  5,6 kN;
- Torsiemoment  $M_{tot}$  19,4 kNm.

De maximale lengte van de ligger is 1,82m (boventraverse HA+0/s). Het profiel van de ligger is HEB220 (S355). De ligger wordt getoetst aan de hand van een excel-sheet. Uit berekening blijkt dat de ligger voldoet met een maximale UC van 0,78. Voor berekening, zie na pagina 6.

## 2.2 Variant B

Onderstaand is de situatie schematisch weergegeven. De hoeklijnen hebben een (minimale) doorsnede van 150x150x14mm. De afstand tussen de hoeklijnen is 600mm. De bovenste en onderste hoeklijnen worden halverwege de overspanning gekoppeld.

De optredende maximale reactiekracht is gelijk aan  $(4,0\text{kN}/2 + 19,4\text{kNm}/0,6\text{m}) = 34,3\text{kN}$ . Per ligger is de kracht gelijk aan  $(34,3\text{kN} / 2 =) 17,2\text{kN}$ .

De maximale overspanning is 2,5m (middentraverse HA+0/c → 150kV heeft langste ligger, deze als maatgevend aangehouden). Het totale moment in het hoekstaal wordt dan  $(0,25 \cdot (17,2\text{kN} + 5,3\text{kN}/2) \cdot 2,5\text{m}) = 12,4\text{kNm}$ .

Het weerstandsmoment is gelijk aan  $83500\text{mm}^3$ . De spanning is gelijk aan  $(12,4 \cdot 10^6 \text{ Nmm} / 83500\text{mm}^3 =) 158\text{MPa}$ . De ligger voldoet met een UC van  $(158\text{MPa} / 355\text{MPa} =) 0,45$ .

De ligger die hoeklijnen koppelt heeft een doorsnede van UNP220 en wordt om de zwakke as belast. Het optredende moment is gelijk aan  $(1/4 \cdot 4,0\text{kN} \cdot 0,6\text{m} + 1/2 \cdot 19,4\text{kNm}) = 10,3\text{kNm}$ . De spanning is gelijk aan  $(10,3 \cdot 10^6 \text{ Nmm} / 33500\text{mm}^3 =) 307\text{MPa}$ . De ligger voldoet met een UC van  $(307\text{MPa} / 355\text{MPa} =) 0,86$ .

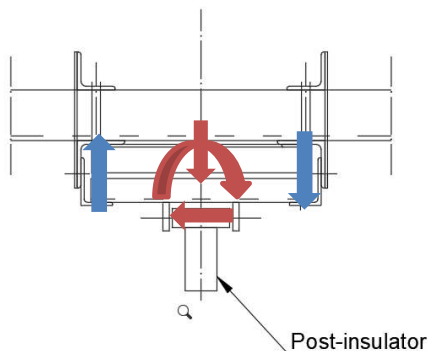

Figuur 6 Schematische weergave ophanging variant 1B

### 3 VARIANT 2 – 150 KV – 1 POSTISOLATOR

Bij deze variant wordt de postisolator opgehangen aan een frame, dit komt overeen met variant 1B. De optredende belastingen zijn:

- Verticaal  $F_v$  2,6 kN;
- Horizontaal  $F_{h,tot}$  3,0 kN;
- Torsiemoment  $M_{tot}$  5,8 kNm.

De belastingen zijn lager en de liggers maximaal even lang als bij variant 1B. Voor variant 2 voldoen profielen 150x150x14mm dus ook, voor uitwerking zie variant 1B.

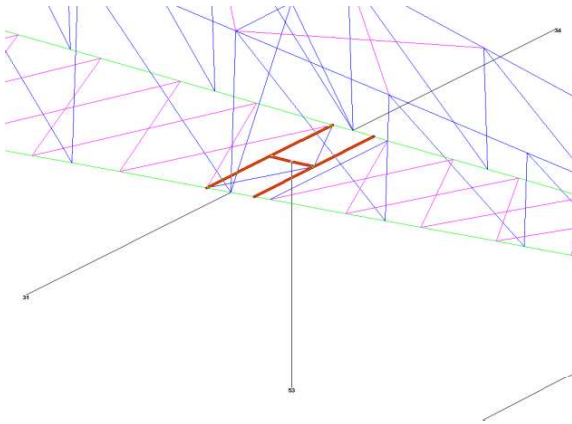

**Figuur 7 Principe ophanging variant 2**



## 4 VARIANT 3 – 150 KV – 2 POST-ISOLATOR

De postisolator wordt via een verlaagde console ingeklemd in twee richtingen opgehangen aan de onderrand van de traverse. De torsie op de onderrand wordt opgenomen door een ligger uit HE-profiel (diagonalen worden verwaarloosd), in de richting van de onderrand neemt de rand de momenten op. De optredende belastingen zijn:

- Verticaal  $F_v$  2,4 kN;
- Horizontaal  $F_{h,tot}$  2,4 kN;
- Torsiemoment  $M_{tot}$  4,1 kNm.

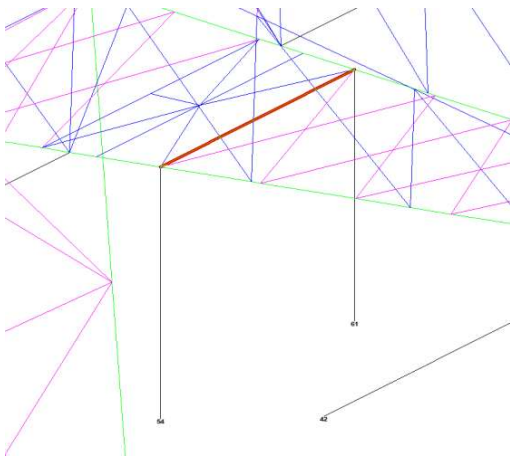

**Figuur 8 Principe ophanging variant 3**

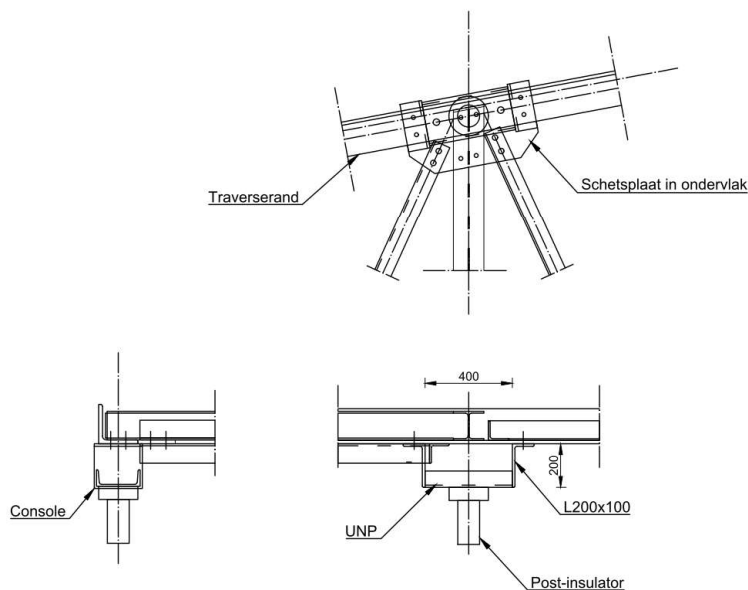

**Figuur 9 Principedetail bevestiging post-isolator aan rand**

De ligger wordt belast door een kopmoment. Dit moment is volgens Tabel 3 gelijk aan 2,4 kNm. Ligger met praktisch gekozen profiel HE140A volstaat.

Kritisch aspect in de verbinding is de krachtsoverdracht van het buigend moment uit het vlak van de console naar de ligger. De onderrand wordt lokaal (tussen de console en HE-ligger) op torsie belast en de flens van het hoekprofiel

wordt ook op buiging belast. Om de krachtsinleiding mogelijk te maken wordt de onderrand verstijfd met een schetsplaat waarmee de HE-ligger en diagonalen worden verbonden.

De controle is uitgevoerd met het programma AxisVM. Zowel buiging in het vlak als buiging uit het vlak is gecontroleerd. Als minimaal profiel van de onderrand is uitgegaan van L150x150x14. De maximale drukkracht in de rand is in combinatie met de buiging meegenomen.

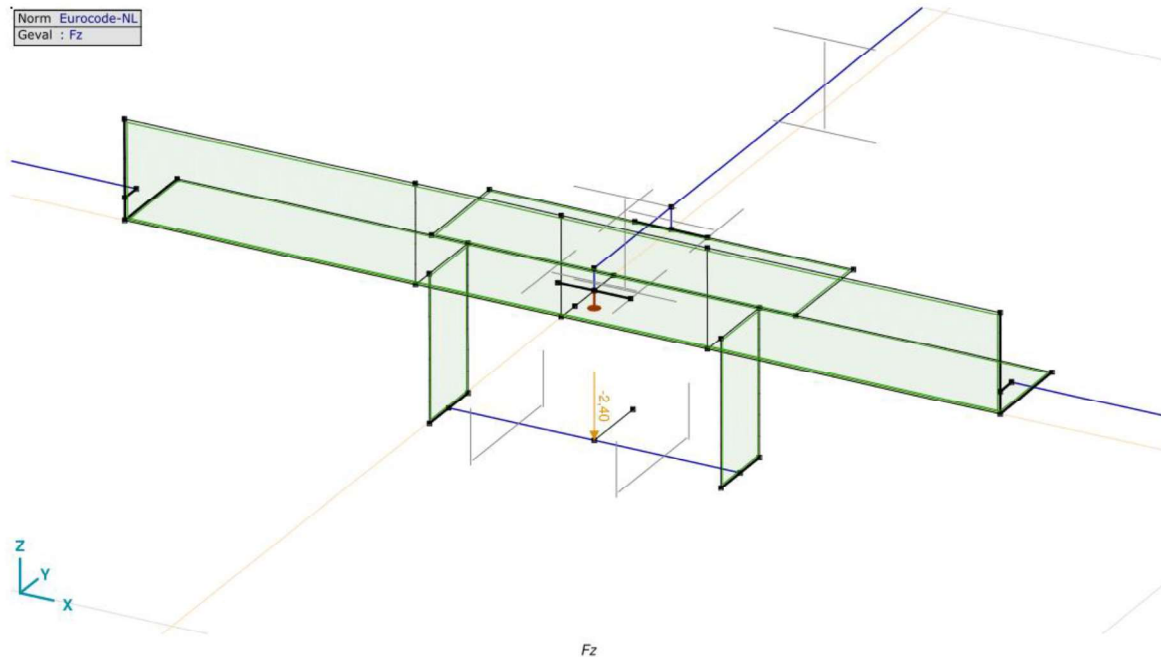

**Figuur 10 Rekenmodel krachtsinleiding post-isolator aan onderrand**

De belastingen zijn ontleend aan Tabel 2 en Tabel 3 voor de 150 kV post-isolator. De belastingen zijn in AxisVM gecombineerd met het verticale gewicht, en met twee richtingen van  $M_x$  en  $M_y$ , waarbij belastinggevallen zijn verminderd tot een factor 0,71.

**Tabel 4 Belastingen op console**

Var.	$F_{z,Ed}$ [kN]	$F_{x,Ed}$ [kN]	$F_{y,Ed}$ [kN]	$M_{x,Ed}$ [kNm]	$M_{y,Ed}$ [kNm]
$M_x$			1,8	2,4	
$M_y$		3,0			5,8
$F_z$	2,4				
$N$	600				

Uit de berekening blijkt dat de combinatie van spanningen door torsie en buiging toelaatbaar is.

Lineaire berekening	
Norm	Eurocode-NL
Geval	Co #3
E (P)	: 2,64E-9
E (W)	: 2,64E-9
E (Eq)	: 2,76E-7
Comp.	: SVM T [N/mm <sup>2</sup> ]

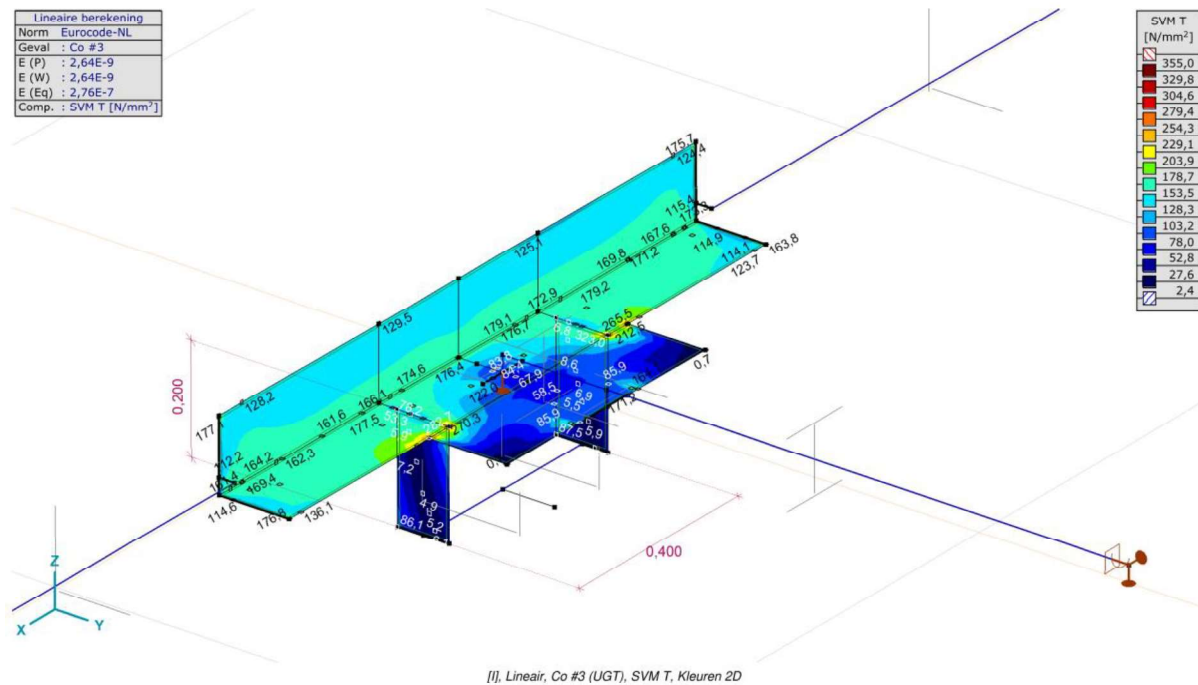

[I], Linear, Co #3 (UGT), SVM T, Kleuren 2D

**Figuur 11 Spanningen in de maatgevende belastingcombinatie**

In het model treden elastisch berekend bij hoeken spanningsconcentraties op. Zie Figuur 11. In de uitvoer opgenomen in de bijlage blijkt dat de hoogste spanning 323 N/mm<sup>2</sup> bedraagt. De toetsing is:

$$U.C. = 323 \text{ N/mm}^2 / 355 \text{ N/mm}^2 = 0,91 \leq 1,00 \text{ OK.}$$

De staalprofielen voldoen.

## **Project:**

**Constructeur: DNV GL - Energy**

AxisVM X5 R4h · Geregistreerd aan DNV GL - Energy  
Model 1.axs

**Rapport**

## Rapport, Inhoudsopgave

<i>Onderdeel</i>	<i>Pagina</i>	<i>Onderdeel</i>	<i>Pagina</i>
Tekening	3	Gebruiker gedefinieerde belastingcombinaties uit belastinggevallen	14
Tekening2	4	[I], Linear, Co #1 (UGT), SVM T, Kleuren 2D	15
Materialen	5	[I], Linear, Co #2 (UGT), SVM T, Kleuren 2D	16
Domeinen	5	[I], Linear, Co #1 (UGT), SVM C, Kleuren 2D	17
Lijnopleggingen	6	[I], Linear, Co #2 (UGT), SVM C, Kleuren 2D	18
Fx	7	[I], Linear, Co #1 (UGT), eY, Lijnen	19
Fx: Oppervlak lijnlast	8	[I], Linear, Co #2 (UGT), eY, Lijnen	20
Fy1	9	[I], Linear, Co #1 (UGT), eZ, Lijnen	21
Fy1: Oppervlak lijnlast	10	[I], Linear, Co #2 (UGT), eZ, Lijnen	22
Fy2	11	[I], Linear, Co #1 (UGT), Ry (lijnoppl.), Doorsnedelijn	23
Fy2: Oppervlak lijnlast	12	[I], Linear, Co #2 (UGT), Ry (lijnoppl.), Doorsnedelijn	24
Fz	13	[I], Linear, Co #1 (UGT), Rz (lijnoppl.), Doorsnedelijn	25
Fz: Oppervlak lijnlast	14	[I], Linear, Co #2 (UGT), Rz (lijnoppl.), Doorsnedelijn	26

**Project:**

Constructeur: DNV GL - Energy

Model: **Model 1.axs**

21-2-2021

Pag. 3

Norm Eurocode-NL

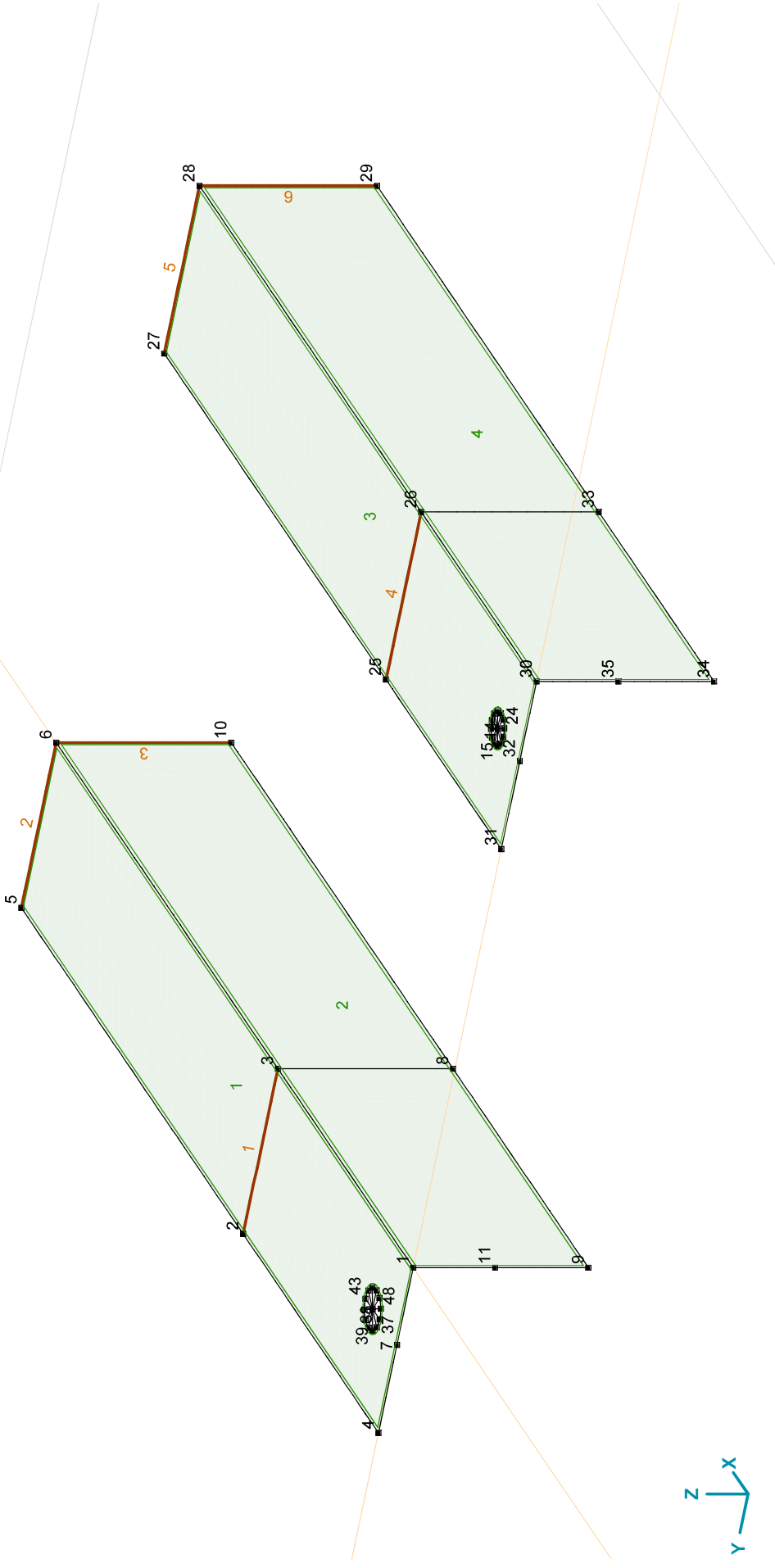

Tekening

**Project:**

Constructeur: DNV GL - Energy

Model: **Model 1.axs**

21-2-2021

Pag. 4

Norm Eurocode-NL

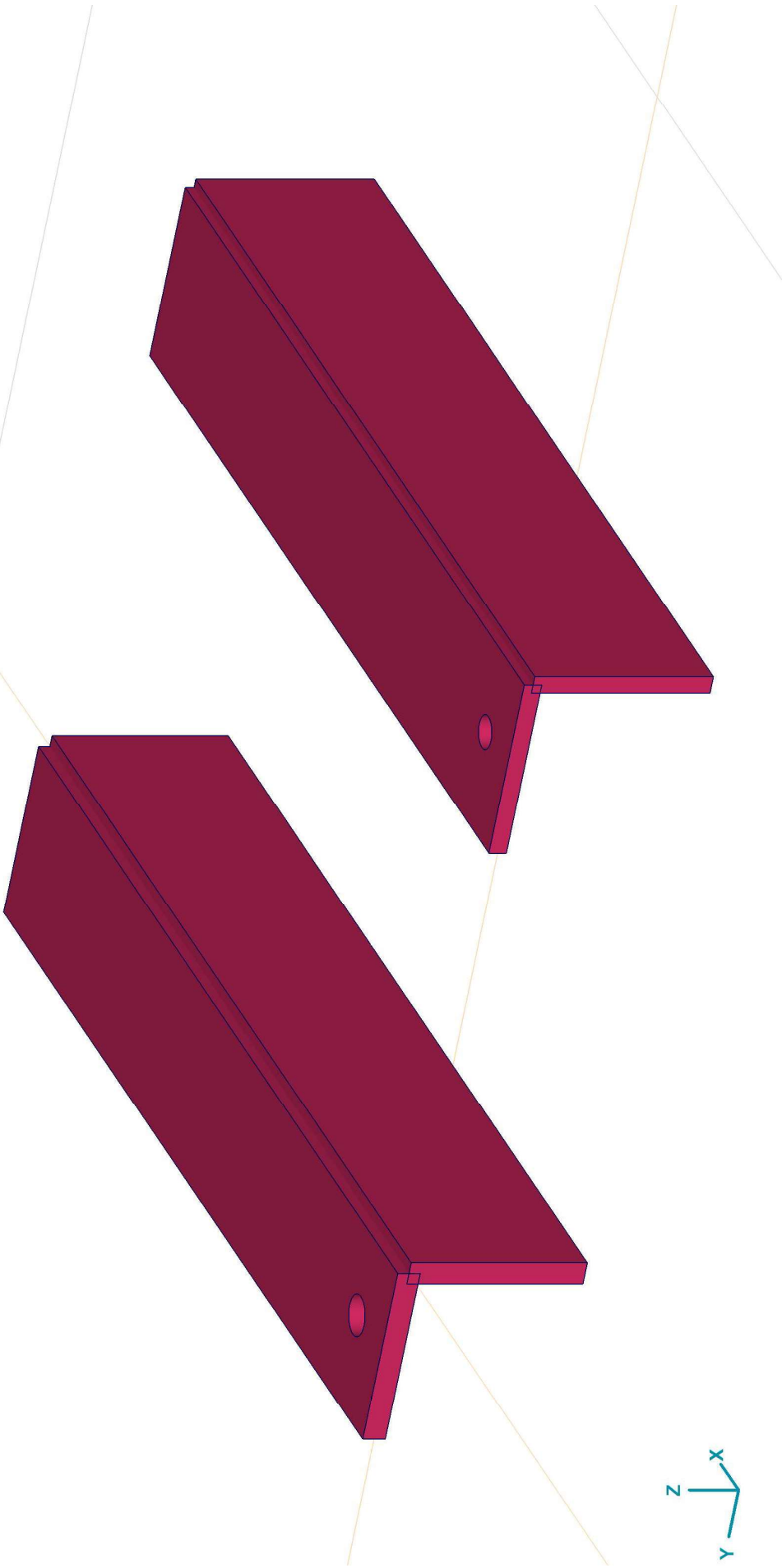

Tekening2

**Project:**



Constructeur: DNV GL - Energy

Model: **Model 1.axs**

21-2-2021

Pag. 5

**Materialen**

Naam	Type	Nationale norm	Materiaalnorm	Model	$E_x$ [N/mm <sup>2</sup> ]	$E_y$ [N/mm <sup>2</sup> ]	$\nu$	$\alpha_T$ [1/°C]	$\rho$ [kg/m <sup>3</sup> ]	Materiaal kleur	Contour kleur	Structuur	
1	S 355	Staal	Eurocode-NL	10025-2	Lineair	210000	210000	0,30	1,2E-5	7850			

Naam	$f_y$ [N/mm <sup>2</sup> ]	$f_u$ [N/mm <sup>2</sup> ]	$E_s$ [N/mm <sup>2</sup> ]	$\nu_s$ [N/mm <sup>2</sup> ]	$E_s$ [N/mm <sup>2</sup> ]	$\nu_s$ [N/mm <sup>2</sup> ]	$E_s$ [N/mm <sup>2</sup> ]	$\nu_s$ [N/mm <sup>2</sup> ]	$E_s$ [N/mm <sup>2</sup> ]	$\nu_s$ [N/mm <sup>2</sup> ]	$E_s$ [N/mm <sup>2</sup> ]	$\nu_s$ [N/mm <sup>2</sup> ]	
1	S 355	$f_y$ [N/mm <sup>2</sup> ] = 355,00	$f_u$ [N/mm <sup>2</sup> ] = 510,00	$E_s$ [N/mm <sup>2</sup> ] = 335,00	$\nu_s$ [N/mm <sup>2</sup> ] = 470,00	$E_s$ [N/mm <sup>2</sup> ] = 335,00	$\nu_s$ [N/mm <sup>2</sup> ] = 470,00	$E_s$ [N/mm <sup>2</sup> ] = 335,00	$\nu_s$ [N/mm <sup>2</sup> ] = 470,00	$E_s$ [N/mm <sup>2</sup> ] = 335,00	$\nu_s$ [N/mm <sup>2</sup> ] = 470,00	$E_s$ [N/mm <sup>2</sup> ] = 335,00	$\nu_s$ [N/mm <sup>2</sup> ] = 470,00

Naam: Materiaalnaam; Type: Type materiaal; Model: Materiaal model;  $E_x$ : Elasticiteitsmodulus in lokale x richting;  $E_y$ : Elasticiteitsmodulus in lokale y richting;  $\nu$ : Poisson's verhouding;  $\alpha_T$ : Warmteuitzettingscoëfficiënt;  $\rho$ : Dichtheid; **Materiaal kleur**: Materiaalkleur; **Contour Meur**: Contourkleur;  $P_1, P_2, P_3, P_4, P_5, P_6, P_7, P_8, P_9, P_{10}, P_{11}, P_{12}, P_{13}, P_{14}$ : Ontwerpparameter;

**Domeinen**

Element type	Materiaal	Ref <sub>x</sub>	Ref <sub>z</sub>	Dikte [mm]	k, buiging	k, torsie	k, afschuiving	Oppervlakte [m <sup>2</sup> ]	Gat	Mesh
1	# Schaal S 355	Auto	Auto	18				0,113	1	✓
2	# Schaal S 355	Auto	Auto	18				0,114	-	✓
3	# Schaal S 355	Auto	Auto	14				0,108	1	✓
4	# Schaal S 355	Auto	Auto	14				0,109	-	✓

**Element type**: Plaalement type; **Ref<sub>x</sub>**: Referentie voor lokale X-richting; **Ref<sub>z</sub>**: Referentie voor lokale Z-richting; **k, buiging**: Buigsterkte coefficient; **k, torsie**: Torsiesterkte coefficient; **k, afschuiving**: Dwarskrachtsterkte coefficient; **Oppervlakte**: Domein oppervlakte; **Gat**: Aantal gaten in domein; **Mesh**: Gegeneerde mesh;



**Project:**

Constructeur: DNV GL - Energy

Model: **Model 1.axs**

21-2-2021

Pag. 6

**Lijnopleggingen**

Lijn	Type	Ref. elem.	Rx [kN/m/m]	Ry [kN/m/m]	Rz [kN/m/m]	Rxx [kNm/rad/m]	Ryy [kNm/rad/m]	Rzz [kNm/rad/m]	NL(x)	NL(y)	NL(z)
1	Rand (2034)	Domein 1	0	1E+7	1E+7	0	0	0		Symmetrisch	Symmetrisch
2	Rand (1959)	Domein 1	1E+10	0	0	0	0	0	Symmetrisch		
3	Rand (104)	Domein 2	1E+10	0	0	0	0	0	Symmetrisch		
4	Rand (3938)	Domein 3	0	1E+7	1E+7	0	0	0		Symmetrisch	Symmetrisch
5	Rand (3866)	Domein 3	1E+10	0	0	0	0	0	Symmetrisch		
6	Rand (5718)	Domein 4	1E+10	0	0	0	0	0	Symmetrisch		

Lijn	NL(xx)	NL(yy)	NL(zz)	F(x) [kN/m]	F(y) [kN/m]	F(z) [kN/m]	M(x) [kNm/m]	M(y) [kNm/m]	M(z) [kNm/m]
1	Rand (2034)								
2	Rand (1959)								
3	Rand (104)								
4	Rand (3938)								
5	Rand (3866)								
6	Rand (5718)								

Lijn: Ondersteund lijnelement; **Type:** Opleggingstype; **Ref. elem.:** Referentie-element; **Rx, Ry, Rz:** Verplaatsingslijfheid; **Rxx, Ryy, Rzz:** Rotatieslijfheid; **NL(x), NL(y), NL(z), NL(xx), NL(yy), NL(zz):** Niet-lineaire parameters; **F(x):** Weerstand in X-richting; **F(y):** Weerstand in Y-richting; **F(z):** Weerstand in Z-richting; **M(x):** Weerstandsmoment in X-richting; **M(y):** Weerstandsmoment in Y-richting; **M(z):** Weerstandsmoment in Z-richting.

**Project:**

Constructeur: DNV GL - Energy

Model: **Model 1.axs**

21-2-2021

Pag. 7

Norm: Eurocode-NL
Geval: Fx

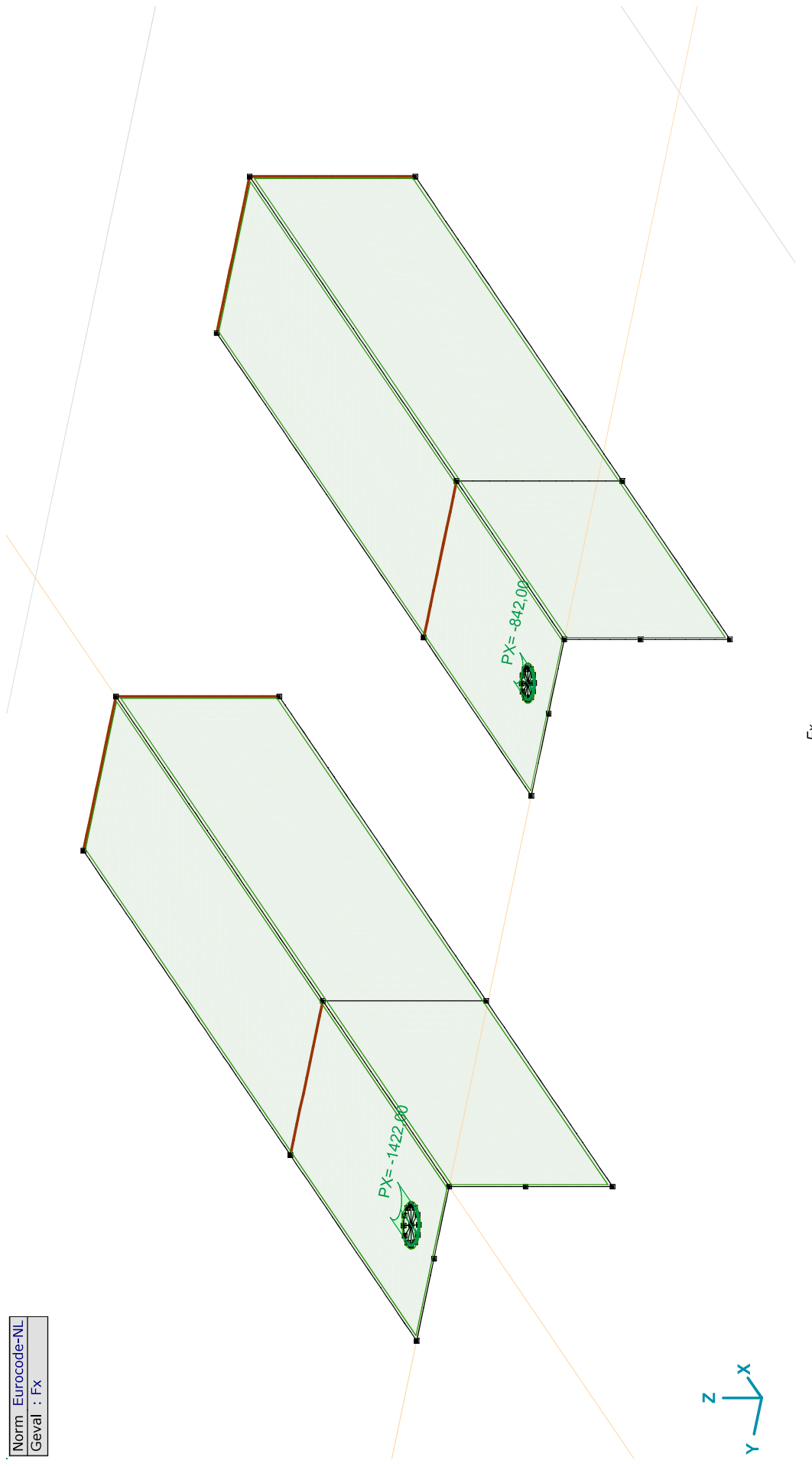

**Project:**

Constructeur: DNV GL - Energy

Model: **Model 1.axis**

21-2-2021

Pag. 8

**Fx: Oppervlak lijnlast**

	<i>Richting</i>	$p_x$ [kN/m]	$p_y$ [kN/m]	$p_z$ [kN/m]	$p_m$ [kNm/m]	$X$ [m]	$Y$ [m]	$Z$ [m]	<i>Richting</i>	$dL$ [m]
1	Global	-1422,00	0	0	0	0,055	0,082	0	(0,055; 0,066; 0,000)	0
		-1422,00	0	0	0	0,055	0,050	0	-	0,050
4	Global	-842,00	0	0	0	0,050	-0,419	0	(0,050; -0,432; 0,000)	0
		-842,00	0	0	0	0,050	-0,445	0	-	0,041

**$p_x$ ,  $p_y$ ,  $p_z$ :** Belastingkracht component;  **$p_m$ :** Belastingmoment component;  **$X$ :** Belasting in X-richting;  **$Y$ :** Belasting in Y-richting;  **$Z$ :** Belasting in Z-richting;

**Project:**

Constructeur: DNV GL - Energy

Model: **Model 1.axs**

21-2-2021

Pag. 9

Norm: Eurocode-NL
Geval: FY1

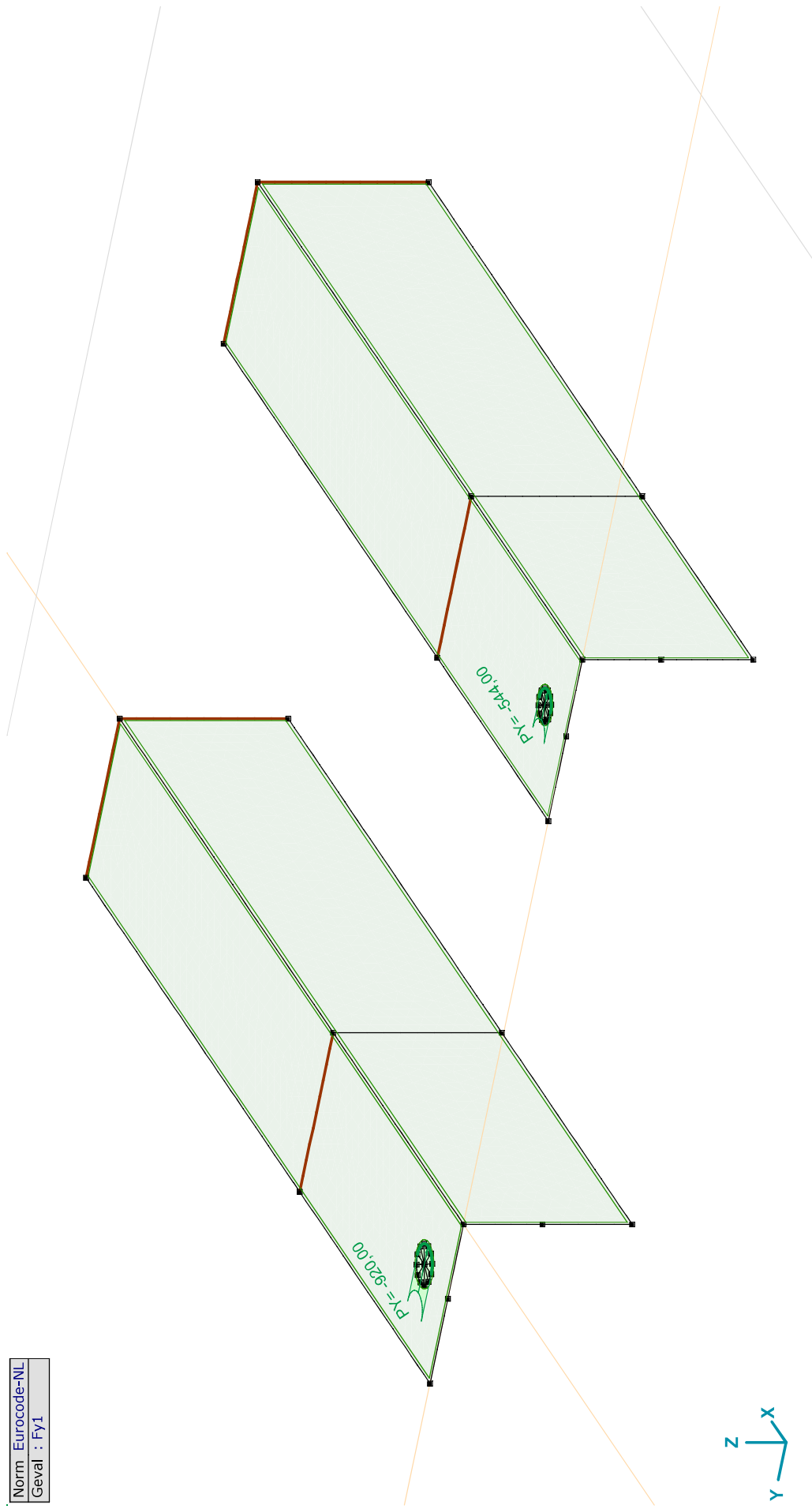

FY1

**Project:**

Constructeur: DNV GL - Energy

Model: **Model 1.axs**

21-2-2021

Pag. 10

**Fy1: Oppervlak lijnlast**

	Richting	$p_x$ [kN/m]	$p_y$ [kN/m]	$p_z$ [kN/m]	$p_m$ [kNm/m]	X [m]	Y [m]	Z [m]	Richting	$dL$ [m]
5	Global	0	-920,00	0	0	0,071	0,066	0	(0,055; 0,066; 0,000)	0
		0	-920,00	0	0	0,039	0,066	0	-	0,050
7	Global	0	-544,00	0	0	0,037	-0,432	0	(0,050; -0,432; 0,000)	0
		0	-544,00	0	0	0,063	-0,432	0	-	0,041

**$p_x$ ,  $p_y$ ,  $p_z$ :** Belastingkracht component;  **$p_m$ :** Belastingmoment component; **X:** Belasting in X-richting; **Y:** Belasting in Y-richting; **Z:** Belasting in Z-richting;

**Project:**

Constructeur: DNV GL - Energy

Model: **Model 1.axs**

21-2-2021

Pag. 11

Norm: Eurocode-NL
Geval: FY2

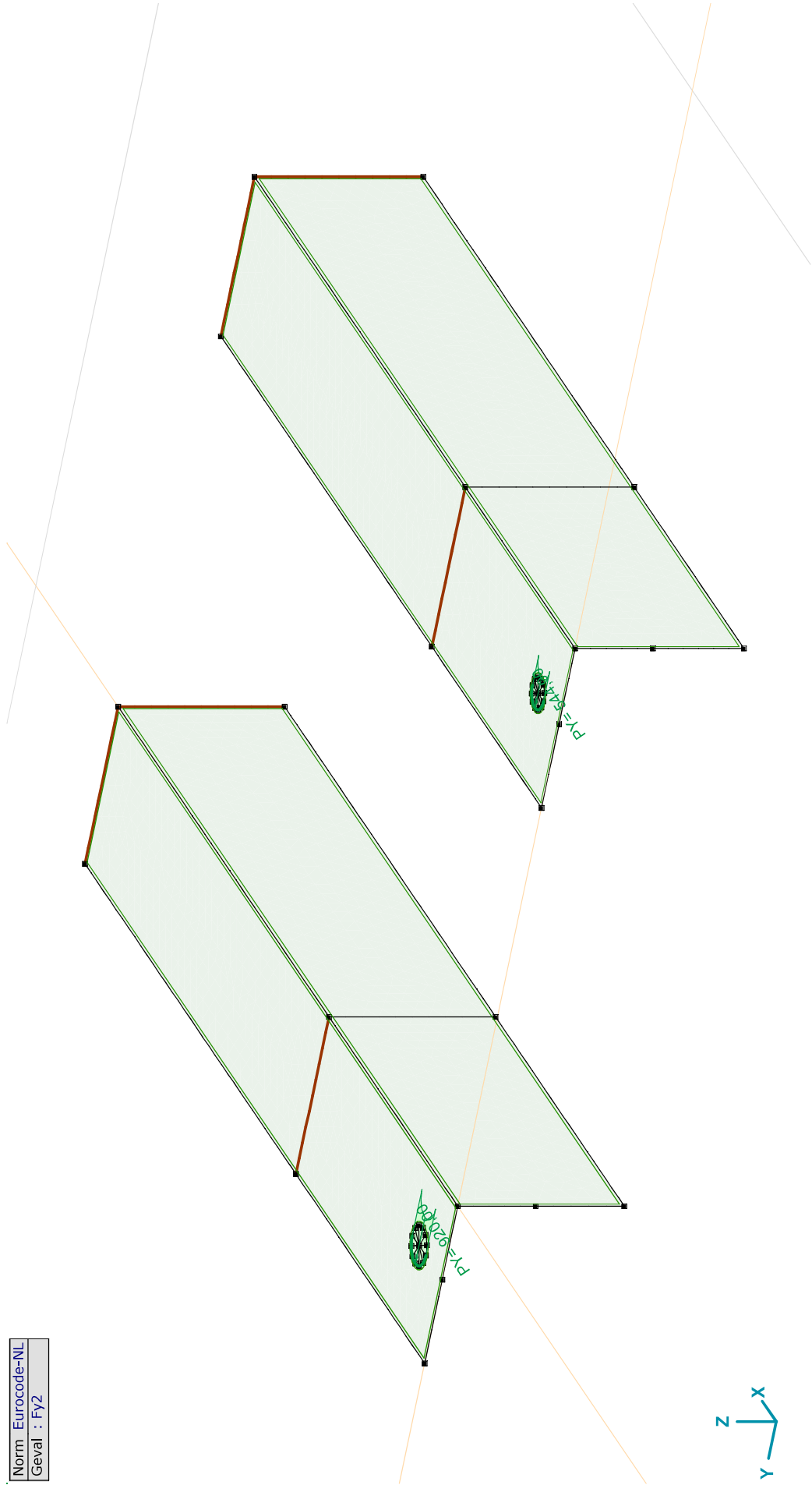

FY2

**Project:**

Constructeur: DNV GL - Energy

Model: **Model 1.axs**

21-2-2021

Pag. 12

**Fy2: Oppervlak lijnlast**

	<i>Richting</i>	$p_x$ [kN/m]	$p_y$ [kN/m]	$p_z$ [kN/m]	$p_m$ [kNm/m]	$X$ [m]	$Y$ [m]	$Z$ [m]	<i>Richting</i>	$dL$ [m]
6	Global	0	920,00	0	0	0,071	0,066	0	(0,055; 0,066; 0,000)	0
		0	920,00	0	0	0,039	0,066	0	-	0,050
8	Global	0	544,00	0	0	0,063	-0,432	0	(0,050; -0,432; 0,000)	0
		0	544,00	0	0	0,037	-0,432	0	-	0,041

**$p_x$ ,  $p_y$ ,  $p_z$ :** Belastingkracht component;  **$p_m$ :** Belastingmoment component;  **$X$ :** Belasting in X-richting;  **$Y$ :** Belasting in Y-richting;  **$Z$ :** Belasting in Z-richting;

**Project:**

Constructeur: DNV GL - Energy

Model: **Model 1.axs**

21-2-2021

Pag. 13

Norm: Eurocode-NL
Geval: Fz

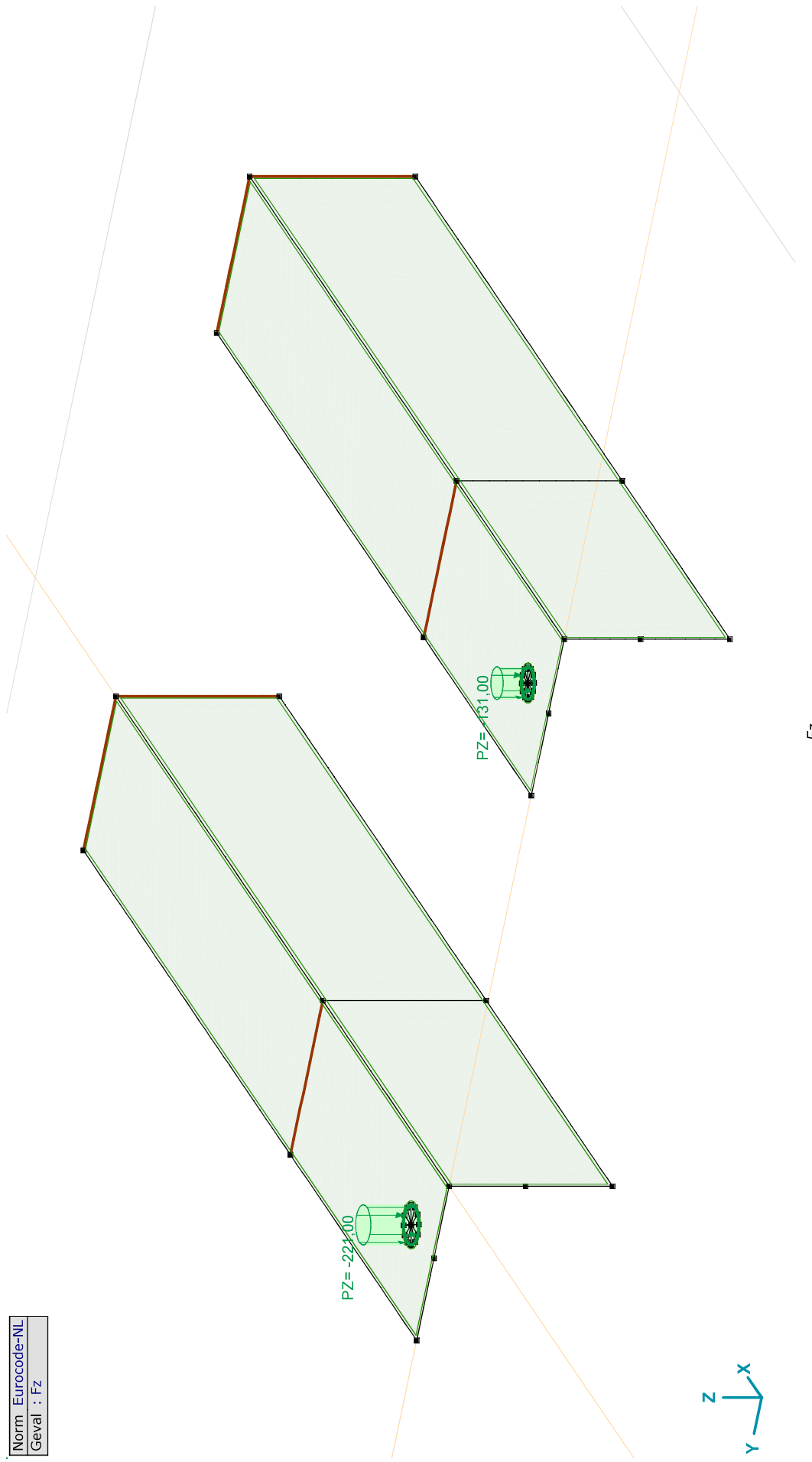

Fz



**Project:**

Constructeur: DNV GL - Energy

Model: **Model 1.axs**

21-2-2021

Pag. 14

**Fz: Oppervlak lijnlast**

	Richting	$p_x$ [kN/m]	$p_y$ [kN/m]	$p_z$ [kN/m]	$p_m$ [kNm/m]	X [m]	Y [m]	Z [m]	Richting	$dL$ [m]
2	Global	0	0	-221,00	0	0,071	0,066	0	(0,055; 0,066; 0,000)	0
		0	0	-221,00	0	0,071	0,066	0	-	0,101
3	Global	0	0	-131,00	0	0,063	-0,432	0	(0,050; -0,432; 0,000)	0
		0	0	-131,00	0	0,063	-0,432	0	-	0,082

**$p_x$ ,  $p_y$ ,  $p_z$ :** Belastingkracht component;  **$p_m$ :** Belastingmoment component; **X:** Belasting in X-richting; **Y:** Belasting in Y-richting; **Z:** Belasting in Z-richting;

**Gebruiker gedefinieerde belastingcombinaties uit belastinggevallen**

	Naam	Type	$F_x$	$F_{y1}$	$F_{y2}$	$F_z$	Commentaar
1	Co #1	UGT	1,00	1,00	0	1,00	
2	Co #2	UGT	1,00	0	1,00	1,00	

**Naam:** Naam belastingcombinatie; **Type:** Type belastingcombinatie;  **$F_x$ ,  $F_{y1}$ ,  $F_{y2}$ ,  $F_z$ :** Factor;

**Project:**

Constructeur: DNV GL - Energy

Model: **Model 1.axs**

21-2-2021

Pag. 15

Lineaire berekening
Norm Eurocode-NL
Geval : Co #1
E (P) : 7,08E-9
E (W) : 7,08E-9
E (Eq) : 1,32E-10
Comp. : SVM T [N/mm <sup>2</sup> ]

SVM T [N/mm <sup>2</sup> ]
268,35
249,26
230,16
211,07
191,97
172,87
153,78
134,68
115,59
96,49
77,40
58,30
39,20
20,11
1,01

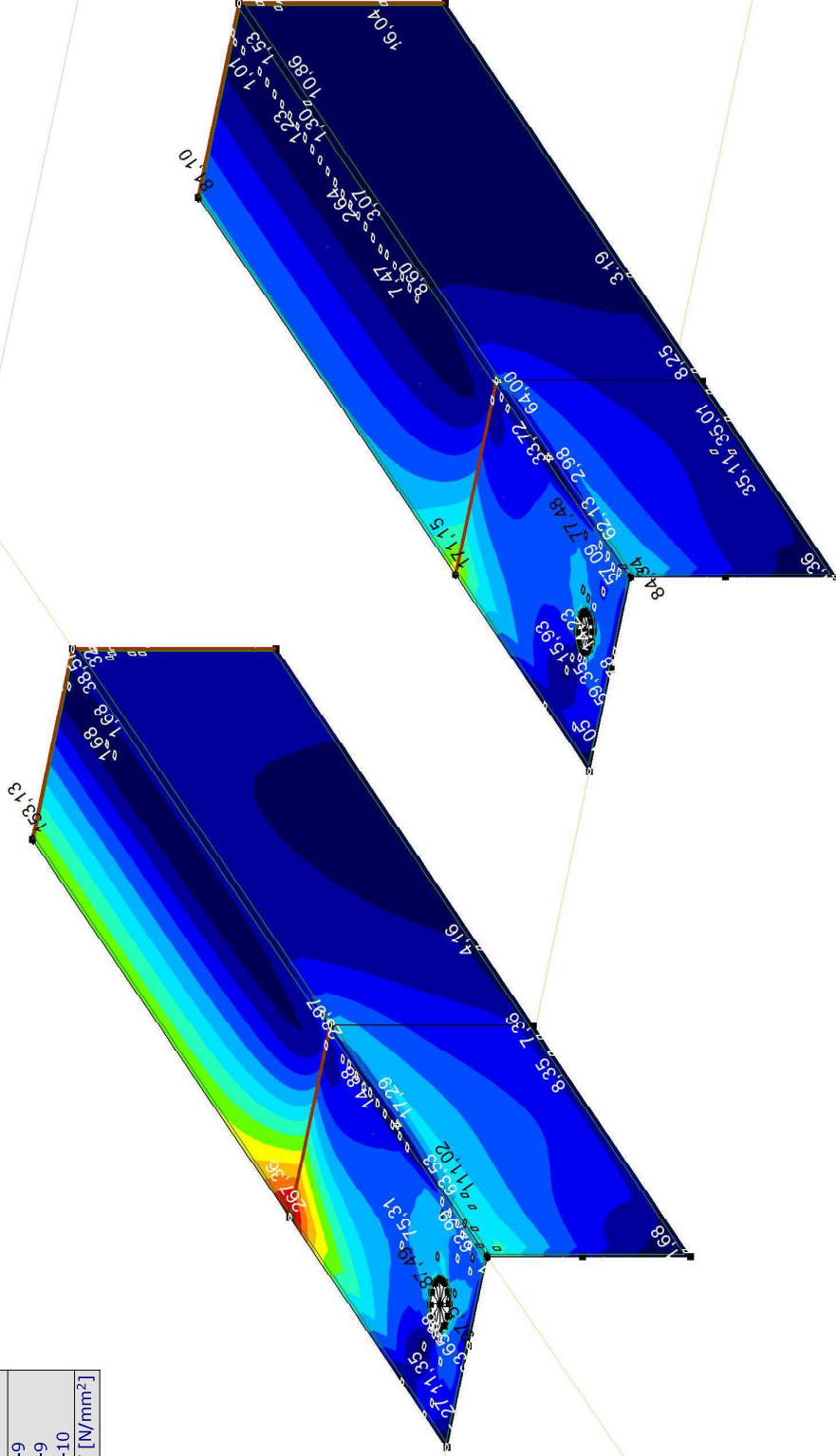

[I]. Lineair, Co #1 (UGT), SVM T, Kleuren 2D

**Project:**

Constructeur: DNV GL - Energy

Model: Model 1.axis

21-2-2021

Pag. 16

Lineaire berekening
Norm Eurocode-NL
Geval : Co #2
E (P) : 7,08E-9
E (W) : 7,08E-9
E (Eq) : 1,32E-10
Comp. : SVM T [N/mm <sup>2</sup> ]

SVM T [N/mm <sup>2</sup> ]
219,10
203,50
187,90
172,30
156,70
141,10
125,50
109,90
94,30
78,70
63,10
47,49
31,89
16,29
0,69

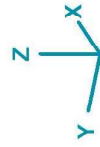
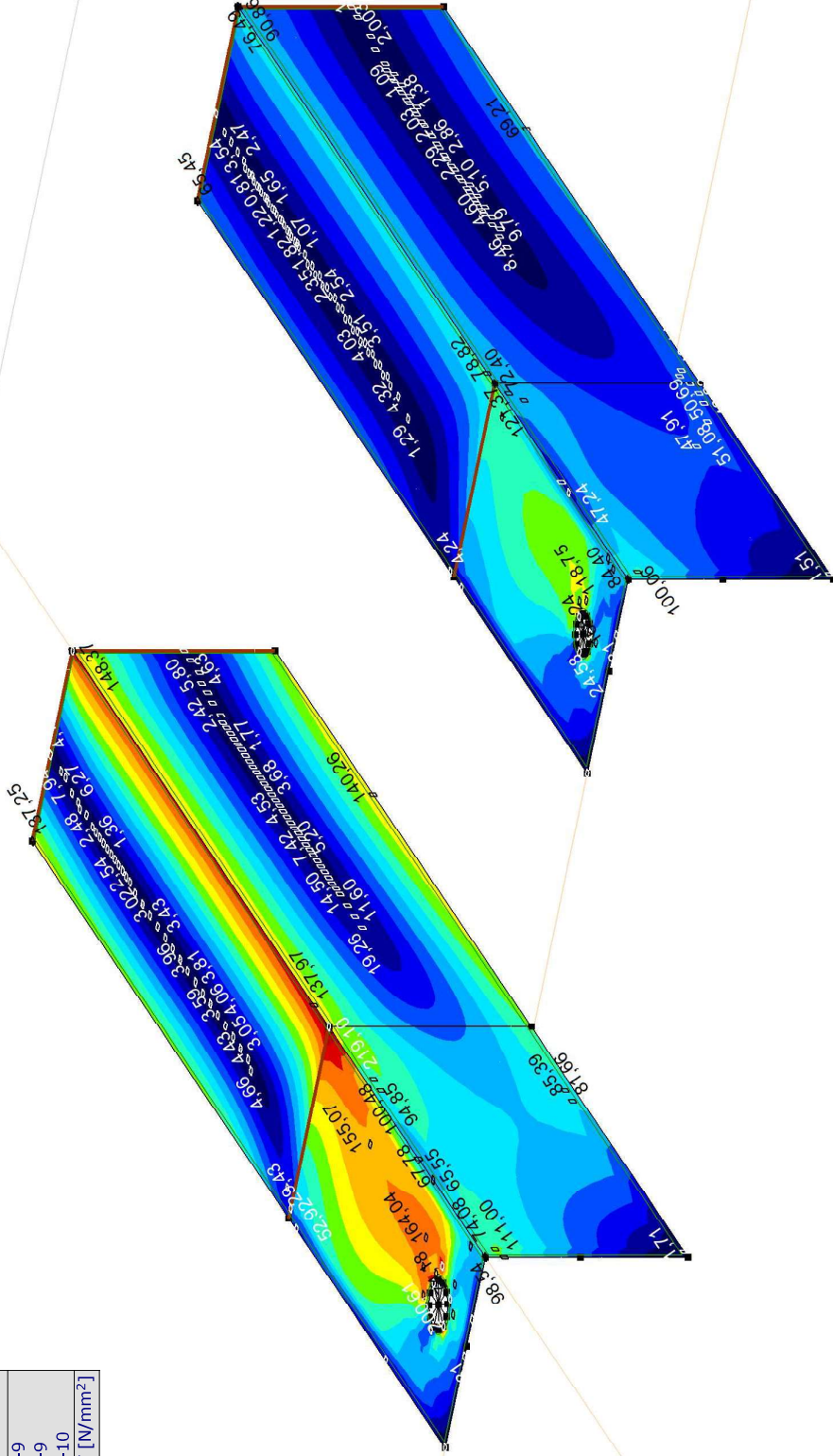

[1]. Lineair, Co #2 (UGT), SVM T, Kleuren 2D

**Project:**  
 Constructeur: DNV GL - Energy  
 Model: **Model 1.axs**

21-2-2021

Pag. 17

Lineaire berekening
Norm Eurocode-NL
Geval : Co #1
E (P) : 7,08E-9
E (W) : 7,08E-9
E (Eq) : 1,32E-10
Comp. : SVM C [N/mm <sup>2</sup> ]

SVM C [N/mm <sup>2</sup> ]
197,50
183,41
169,32
155,23
141,15
127,06
112,97
98,88
84,79
70,71
56,62
42,53
28,44
14,36
0,27

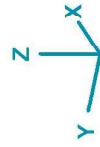
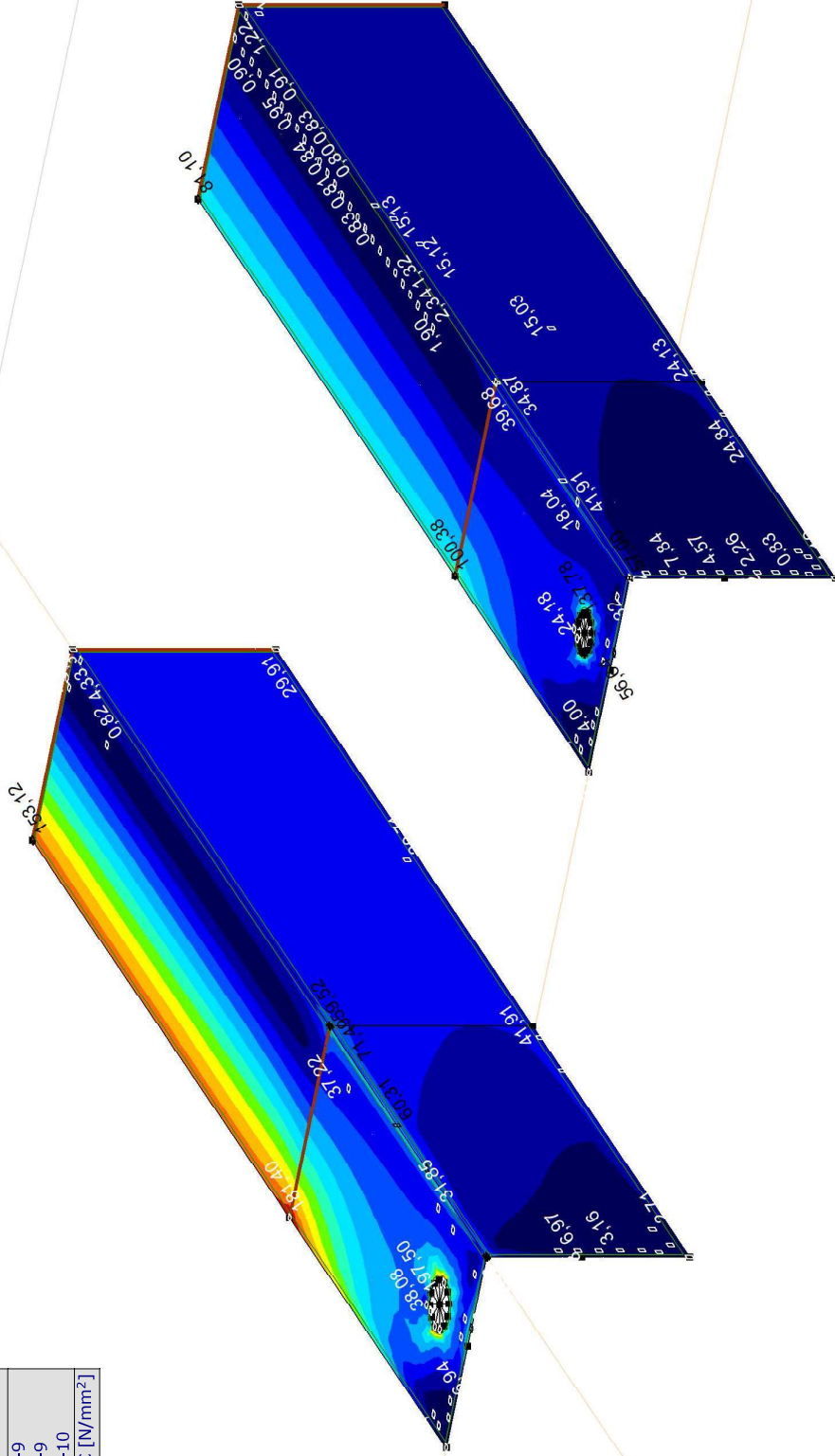

III. Lineair, Co #1 (UGT), SVM C, Kleuren 2D

**Project:**

Constructeur: DNV GL - Energy

Model: Model 1.axs

21-2-2021

Pag. 18

Lineaire berekening
Norm Eurocode-NL
Geval : Co #2
E (P) : 7,08E-9
E (W) : 7,08E-9
E (Eq) : 1,32E-10
Comp. : SVM C [N/mm <sup>2</sup> ]

SVM C [N/mm <sup>2</sup> ]
192,93
179,17
165,42
151,66
137,90
124,14
110,38
96,62
82,86
69,10
55,35
41,59
27,83
14,07
0,31

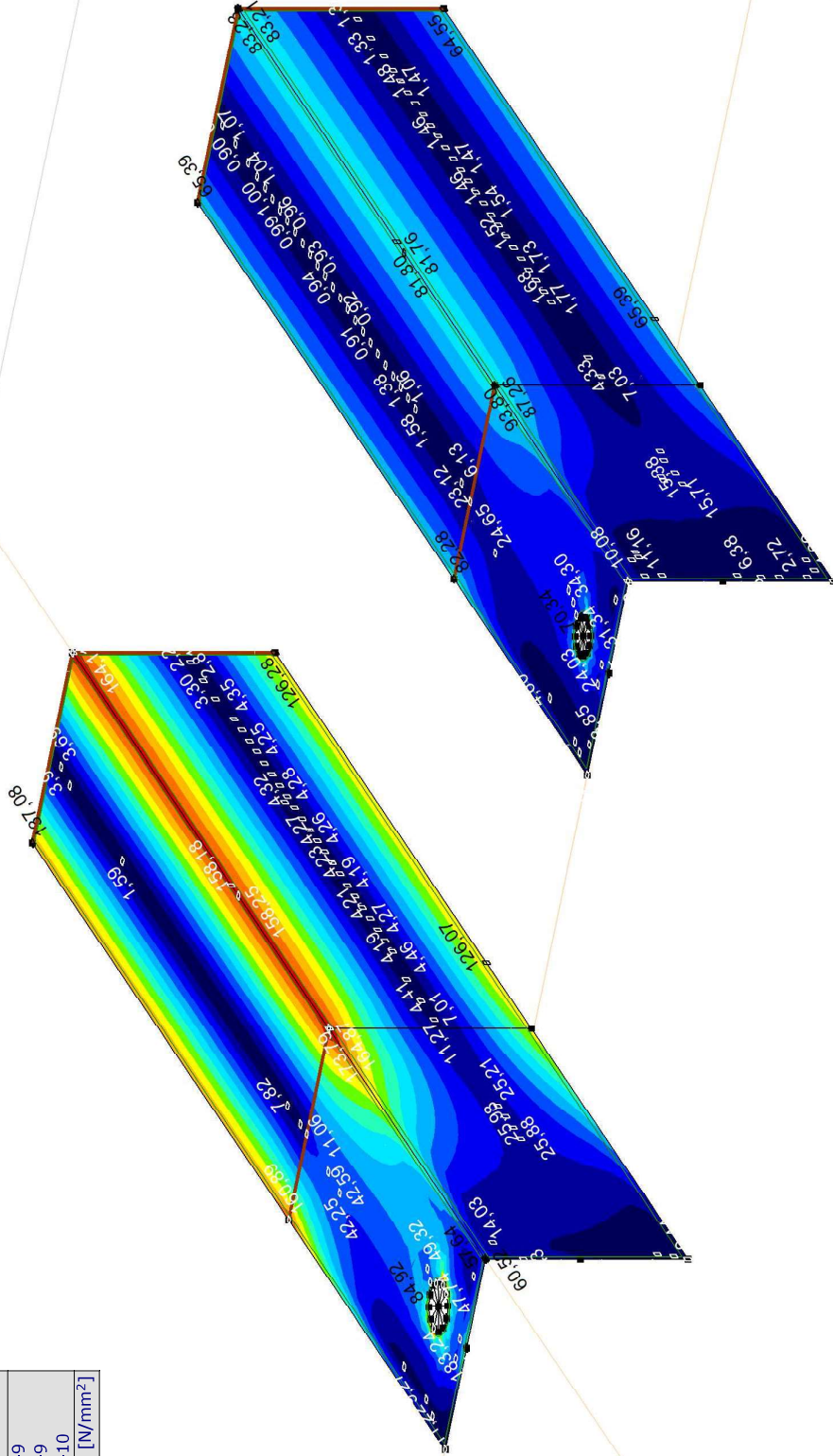

III. Lineair, Co #2 (UGT), SVM C, Kleuren 2D



**Project:**

Constructeur: DNV GL - Energy

Model: **Model 1.axis**

21-2-2021

Pag. 19

Lineaire berekening	
Norm	Eurocode-NL
Geval	: Co #1
E (P)	: 7,08E-9
E (W)	: 7,08E-9
E (Eq)	: 1,32E-10
Comp.	: eY [mm]

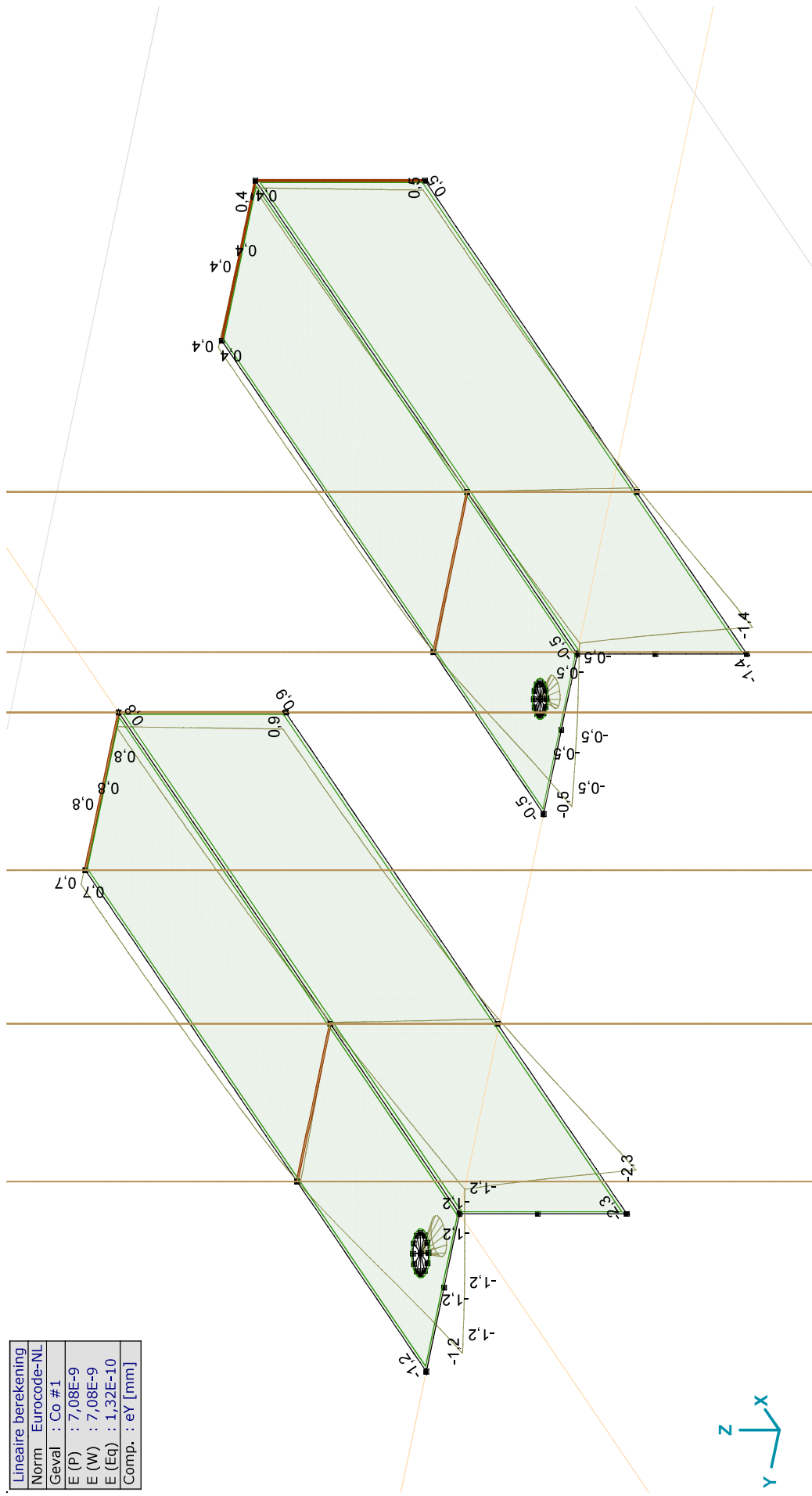

[[J. Lineair, Co #1 (UGT), eY, Lijnen

**Project:**

Constructeur: DNV GL - Energy

Model: **Model 1.axis**

21-2-2021

Pag. 20

Lineaire berekening
Norm Eurocode-NL
Geval : Co #2
E (P) : 7,08E-9
E (W) : 7,08E-9
E (Eq) : 1,32E-10
Comp. : eY [mm]

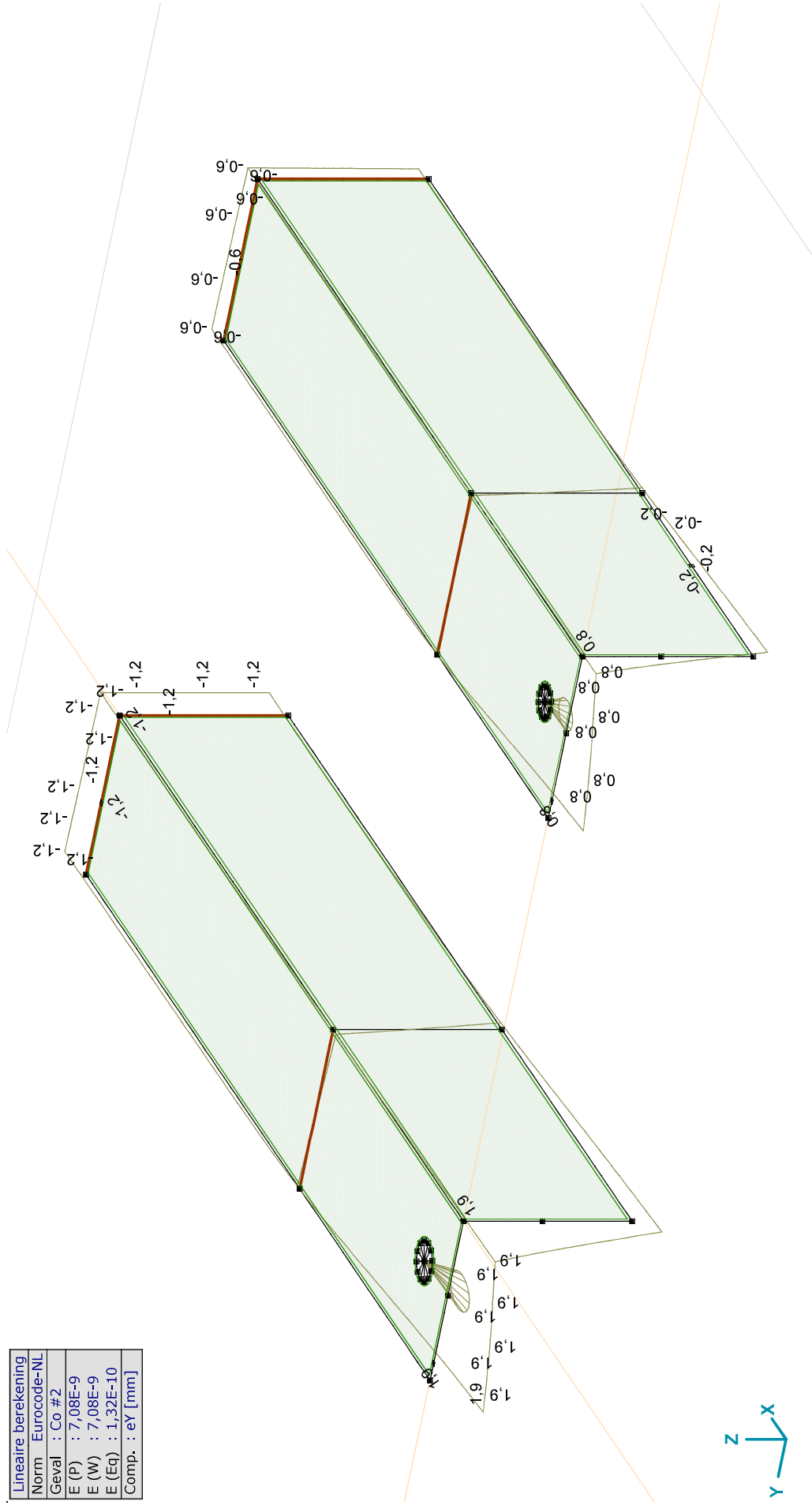

[1]. Lineair, Co #2 (UGT), eY, Lijnen

**Project:**

Constructeur: DNV GL - Energy

Model: **Model 1.axs**

21-2-2021

Pag. 21

Lineaire berekening
Norm Eurocode-NL
Geval : Co #1
E (P) : 7,08E-9
E (W) : 7,08E-9
E (Eq) : 1,32E-10
Comp. : eZ [mm]

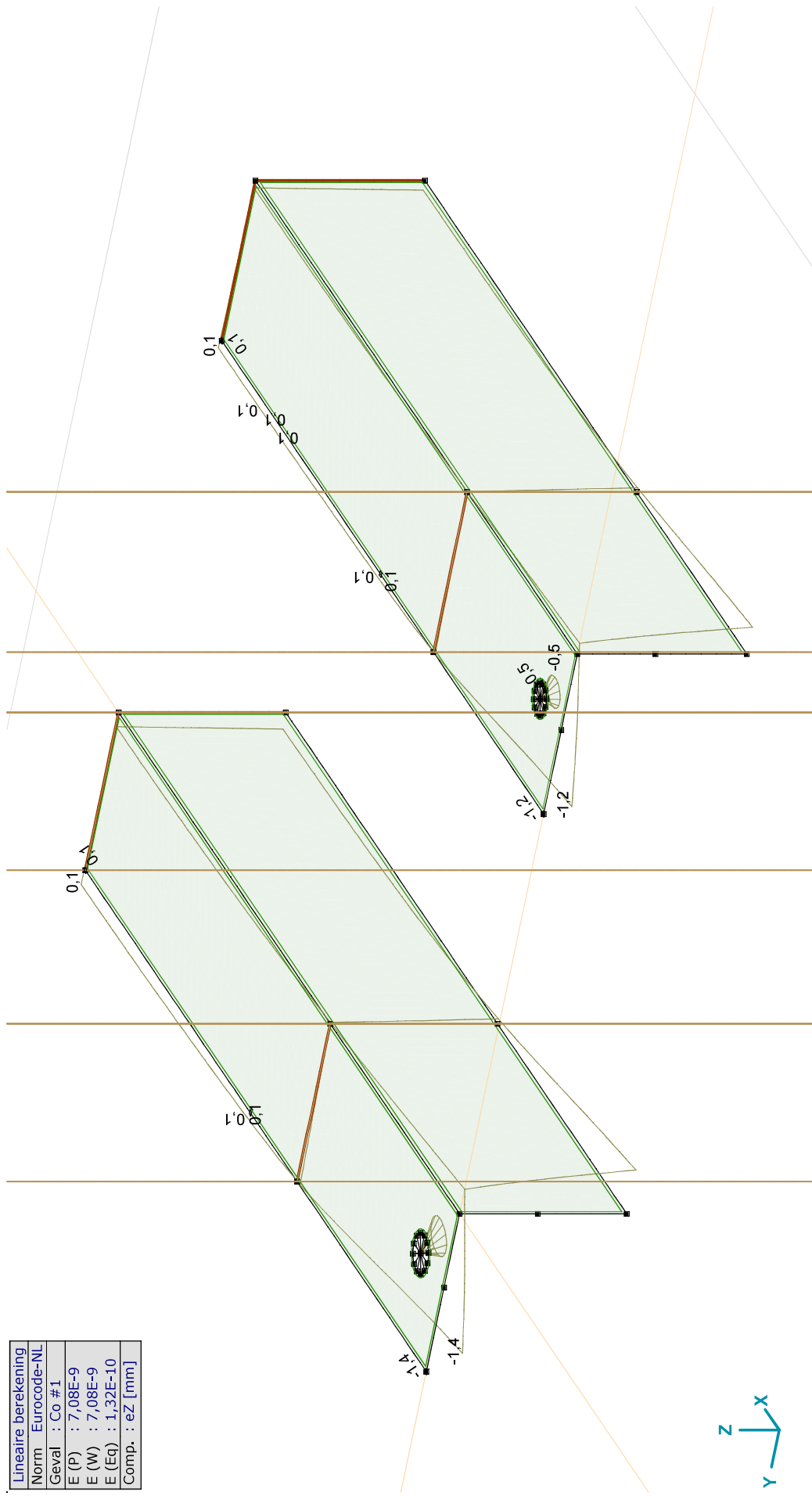

[[J. Lineair, Co #1 (UGT), eZ, Lijnen





**Project:**  
 Constructeur: DNV GL - Energy  
 Model: Model 1.axs

21-2-2021

Pag. 23

Lineaire berekening
Norm Eurocode-NL
Geval : Co #1
E (P) : 7,08E-9
E (W) : 7,08E-9
E (Eq) : 1,32E-10
Comp. : Ry [kN/m]

Ry [kN/m]	0
	-28,5
	-57,0
	-85,4
	-113,9
	-142,4
	-170,9
	-199,4
	-227,9
	-256,4
	-284,8
	-313,3
	-341,8
	-370,3
	-398,8

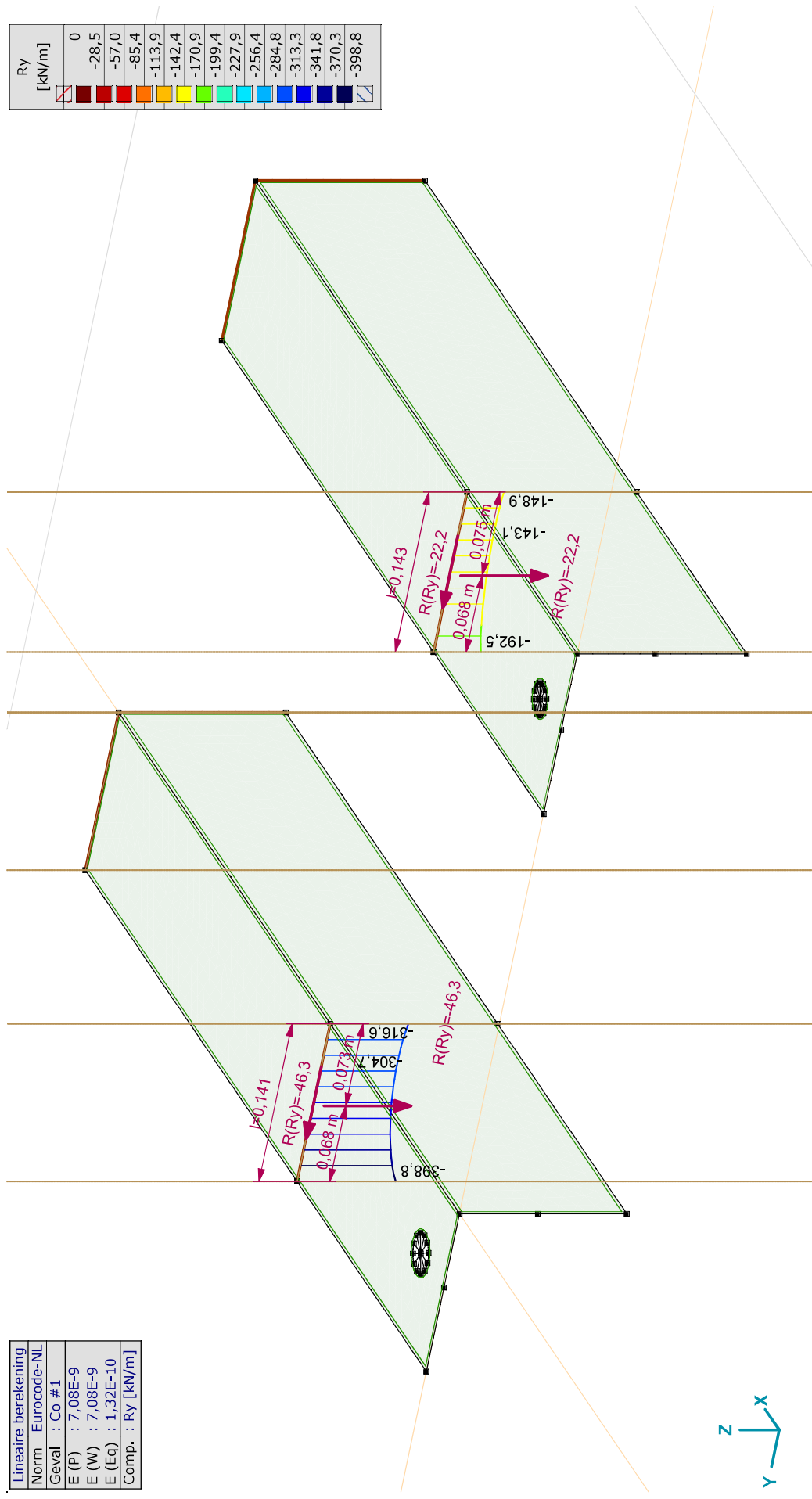

III. Lineair, Co #1 (UGT), Ry (lijnopp.), Doorsnedelij

**Project:**

Constructeur: DNV GL - Energy

Model: **Model 1.axis**

21-2-2021

Pag. 24

Lineaire berekening	
Norm	Eurocode-NL
Geval	: Co #2
E (P)	: 7,08E-9
E (W)	: 7,08E-9
E (Eq)	: 1,32E-10
Comp.	: Ry [kN/m]

Ry [kN/m]	
386,6	
359,0	
331,4	
303,7	
276,1	
248,5	
220,9	
193,3	
165,7	
138,1	
110,5	
82,8	
55,2	
27,6	
0	

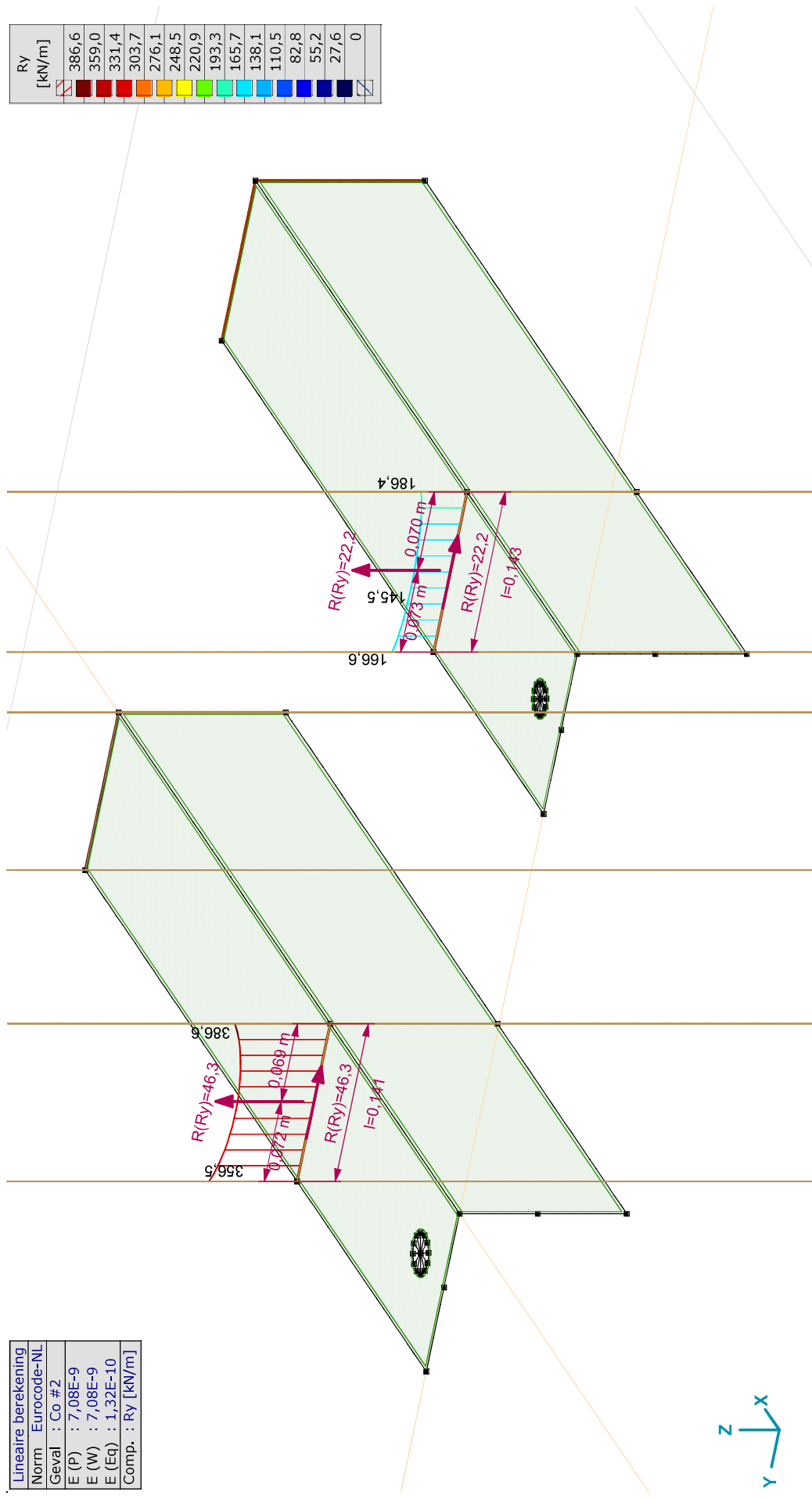

III. Lineair, Co #2 (UGT), Ry (lijnopp.), Doorsnedelij

**Project:**

Constructeur: DNV GL - Energy

Model: **Model 1.axis**

21-2-2021

Pag. 25

Lineaire berekening
Norm Eurocode-NL
Geval : Co #1
E (P) : 7,08E-9
E (W) : 7,08E-9
E (Eq) : 1,32E-10
Comp. : Rz [kN/m]

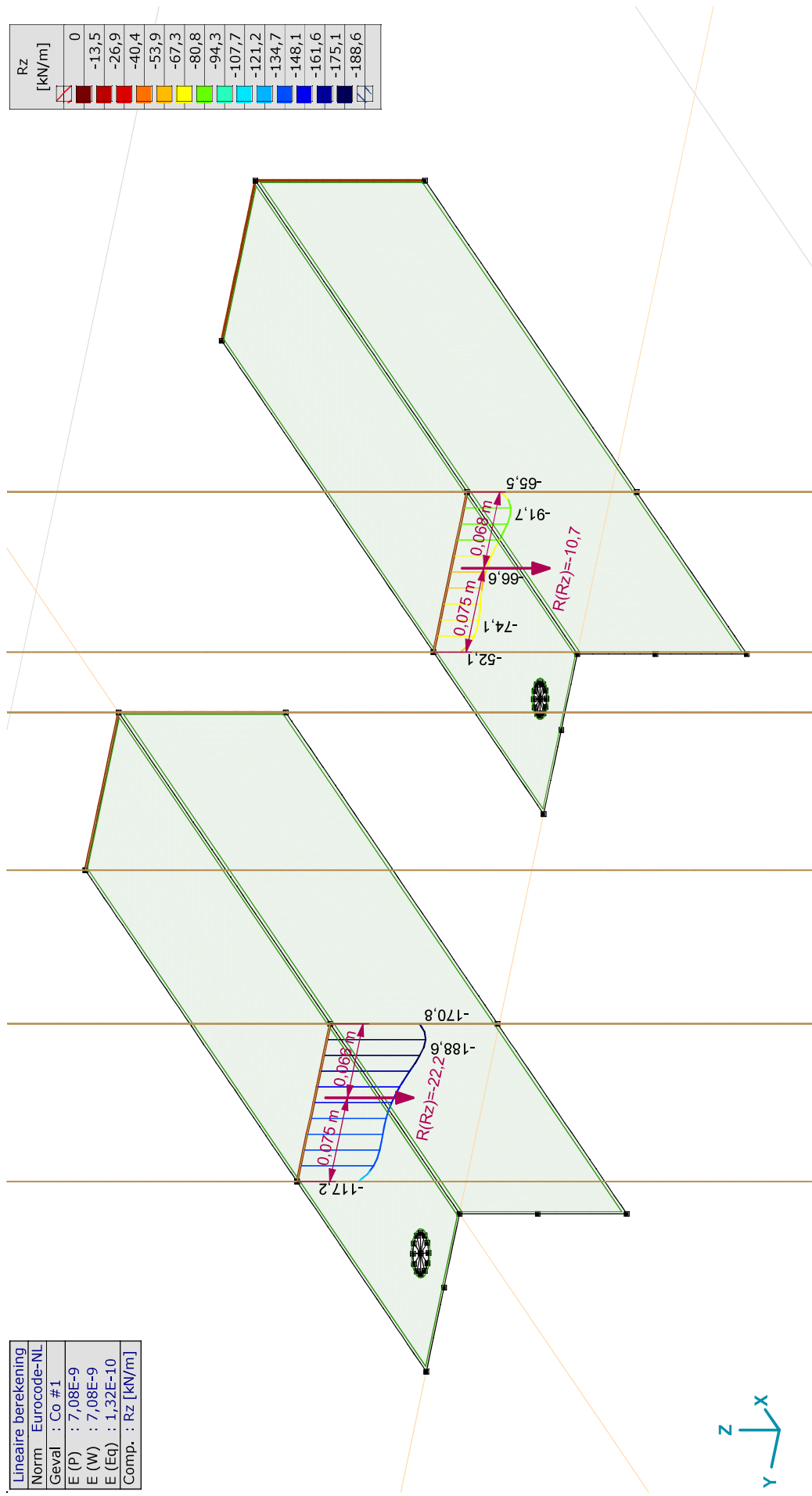
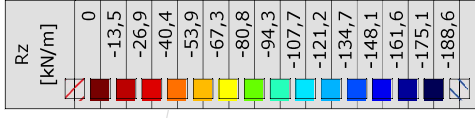

III. Lineair, Co #1 (UGT), Rz (lijnopp.), Doorsnedelij

**Project:**

Constructeur: DNV GL - Energy

Model: **Model 1.axs**

21-2-2021

Pag. 26

Lineaire berekening	
Norm	Eurocode-NL
Geval	: Co #2
E (P)	: 7,08E-9
E (W)	: 7,08E-9
E (Eq)	: 1,32E-10
Comp.	: Rz [kN/m]

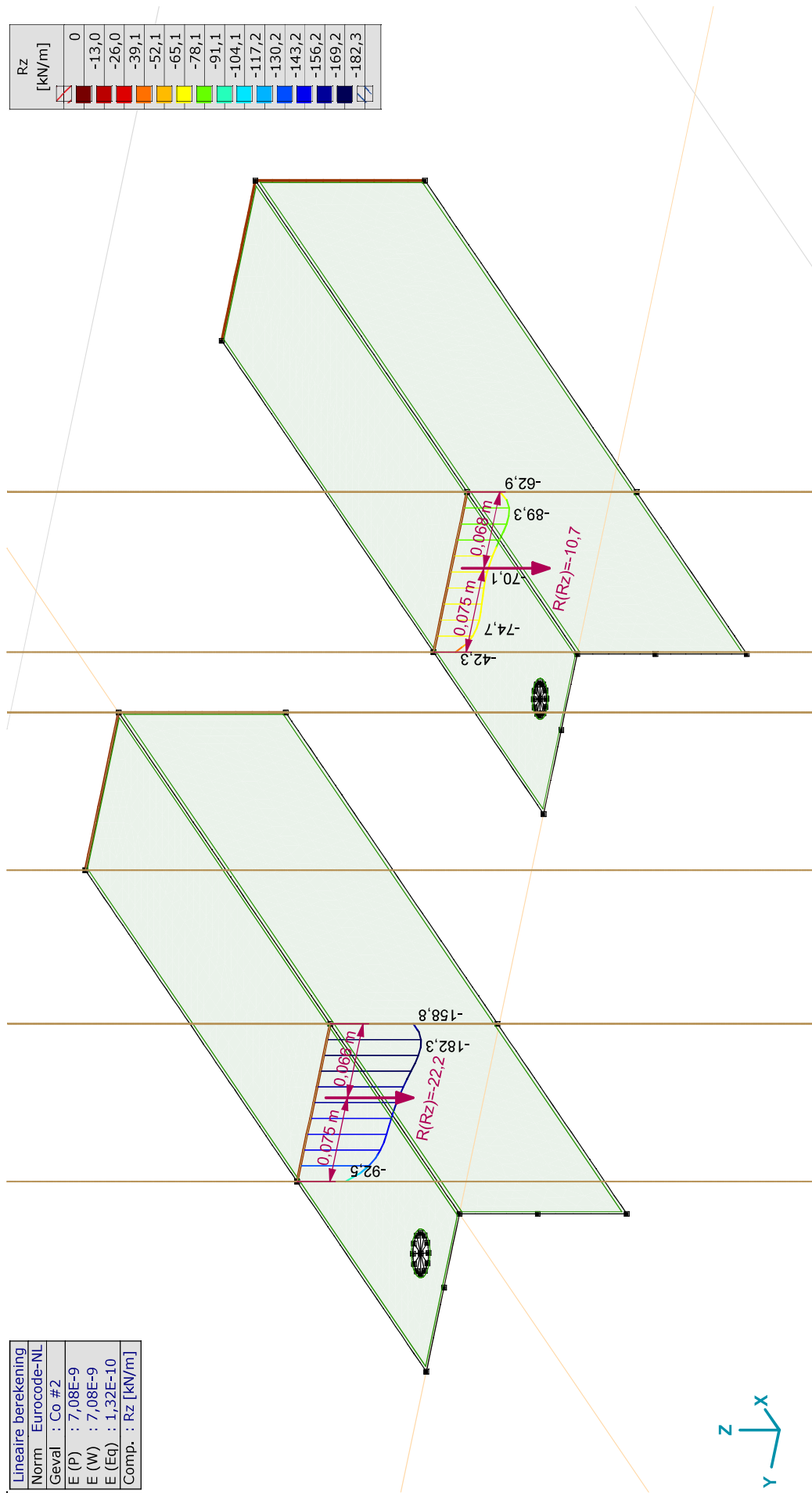
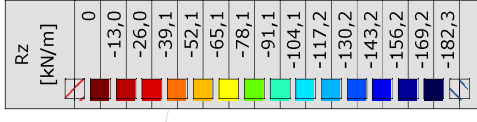

III. Lineair, Co #2 (UGT), Rz (lijnopp.), Doorsnedelij

## **Project:**

**Constructeur: DNV GL - Energy**

AxisVM X5 R4h • Geregistreerd aan DNV GL - Energy  
Post aan onderstrand.axs

**Rapport**

## Rapport, Inhoudsopgave

	Onderdeel	Pagina	Onderdeel	Pagina
	Materialen	3	[I], Lineair, Omhullende (Alle UGT), Tx, Lijnen (gevuld)	18
	Knoppen en staven	4	[I], Lineair, Co #1 (UGT), eR, Lijnen	19
	Dikte	5	[I], Lineair, Co #2 (UGT), eR, Lijnen	20
	Profielen	6	[I], Lineair, Co #3 (UGT), eR, Lijnen	21
	Domijnen	7	[I], Lineair, Co #4 (UGT), eR, Lijnen	22
	Knooppoppelingen	7	[I], Lineair, Co #5 (UGT), eR, Lijnen	23
	Mx: Knoopbelastingen	8	[I], Lineair, Co #6 (UGT), eR, Lijnen	24
	Mx	8	[I], Lineair, Co #1 (UGT), SVM T, Kleuren 2D	25
	My: Knoopbelastingen	9	[I], Lineair, Co #2 (UGT), SVM T, Kleuren 2D	26
	My	9	[I], Lineair, Co #3 (UGT), SVM T, Kleuren 2D	27
	Fz: Knoopbelastingen	10	[I], Lineair, Co #4 (UGT), SVM T, Kleuren 2D	28
	Fz	10	[I], Lineair, Co #5 (UGT), SVM T, Kleuren 2D	29
	N: Knoopbelastingen	11	[I], Lineair, Co #6 (UGT), SVM T, Kleuren 2D	30
	N	11	[I], Lineair, Omhullende (Alle UGT), SVM B, Iso vlakken 3D	31
	Gebruiker gedefinieerde belastingcombinaties uit belastinggevallen	12	[I], Lineair, Omhullende (Alle UGT), SVM C, Iso vlakken 3D	32
	[I], Lineair, Omhullende (Alle UGT), Nx, Lijnen (gevuld)	13	[I], Lineair, Omhullende (Alle UGT), SVM T, Iso vlakken 3D	33
	[I], Lineair, Omhullende (Alle UGT), My, Lijnen (gevuld)	14	Vlakspanningen [Lineair, Omhullende (Alle UGT)]	34
	[I], Lineair, Omhullende (Alle UGT), Mz, Lijnen (gevuld)	15	[I], Lineair, Omhullende (Alle UGT), S;x;minmax, Lijnen (gevuld)	35
	[I], Lineair, Omhullende (Alle UGT), Vz, Lijnen (gevuld)	16	Staafspanningen [Lineair, Omhullende (Alle UGT)]	36
	[I], Lineair, Omhullende (Alle UGT), Vy, Lijnen (gevuld)	17	Interne krachten knooppoplegging [Lineair, Omhullende (Alle UGT)]	37

**Project:**



Constructeur: DNV GL - Energy

Model: **Post aan onderrand.axs**

6-3-2021

Pag. 3

**Materialen**

Naam	Type	Nationale norm	Materialnorm	Model	$E_x$ [N/mm <sup>2</sup> ]	$E_y$ [N/mm <sup>2</sup> ]	$\nu$	$\alpha_T$ [1/°C]	$\rho$ [kg/m <sup>3</sup> ]	Material kleur	Contour kleur	Structuur	$P_1$
1	S 355	Staal	Eurocode-NL 10025-2	Lineair	210000	210000	0.30	1,2E-5	7850				$f_y$ [N/mm <sup>2</sup> ] = 355.00

Naam	$f_u$ [N/mm <sup>2</sup> ]	$f_c^y$ [N/mm <sup>2</sup> ]	$f_c^x$ [N/mm <sup>2</sup> ]	$P_2$	$P_3$	$P_4$	$P_5$	$P_6$	$P_7$	$P_8$	$P_9$	$P_{10}$	$P_{11}$	$P_{12}$	$P_{13}$	$P_{14}$
1	S 355	$f_u$ [N/mm <sup>2</sup> ] = 510.00	$f_c^y$ [N/mm <sup>2</sup> ] = 335.00	$f_c^x$ [N/mm <sup>2</sup> ] = 470.00												

**Naam:** Materiaalnaam; **Type:** Type materiaal; **Model:** Materiaal model;  **$E_x$ :** Elasticiteitsmodulus in lokale x richting;  **$E_y$ :** Elasticiteitsmodulus in lokale y richting;  **$\nu$ :** Poisson's verhouding;  **$\alpha_T$ :** Warmteuitzettingscoëfficiënt;  **$\rho$ :** Dichtheid; **Materiaal kleur:** Materiaalkleur; **Contour kleur:**  $P_1, P_2, P_3, P_4, P_5, P_6, P_7, P_8, P_9, P_{10}, P_{11}, P_{12}, P_{13}, P_{14}$ : Ontwerpparameter;



**Project:**  
Constructeur: DNV GL - Energy  
Model: **Post aan onderrand.axs**

Norm Eurocode-NL
Geval : Fz

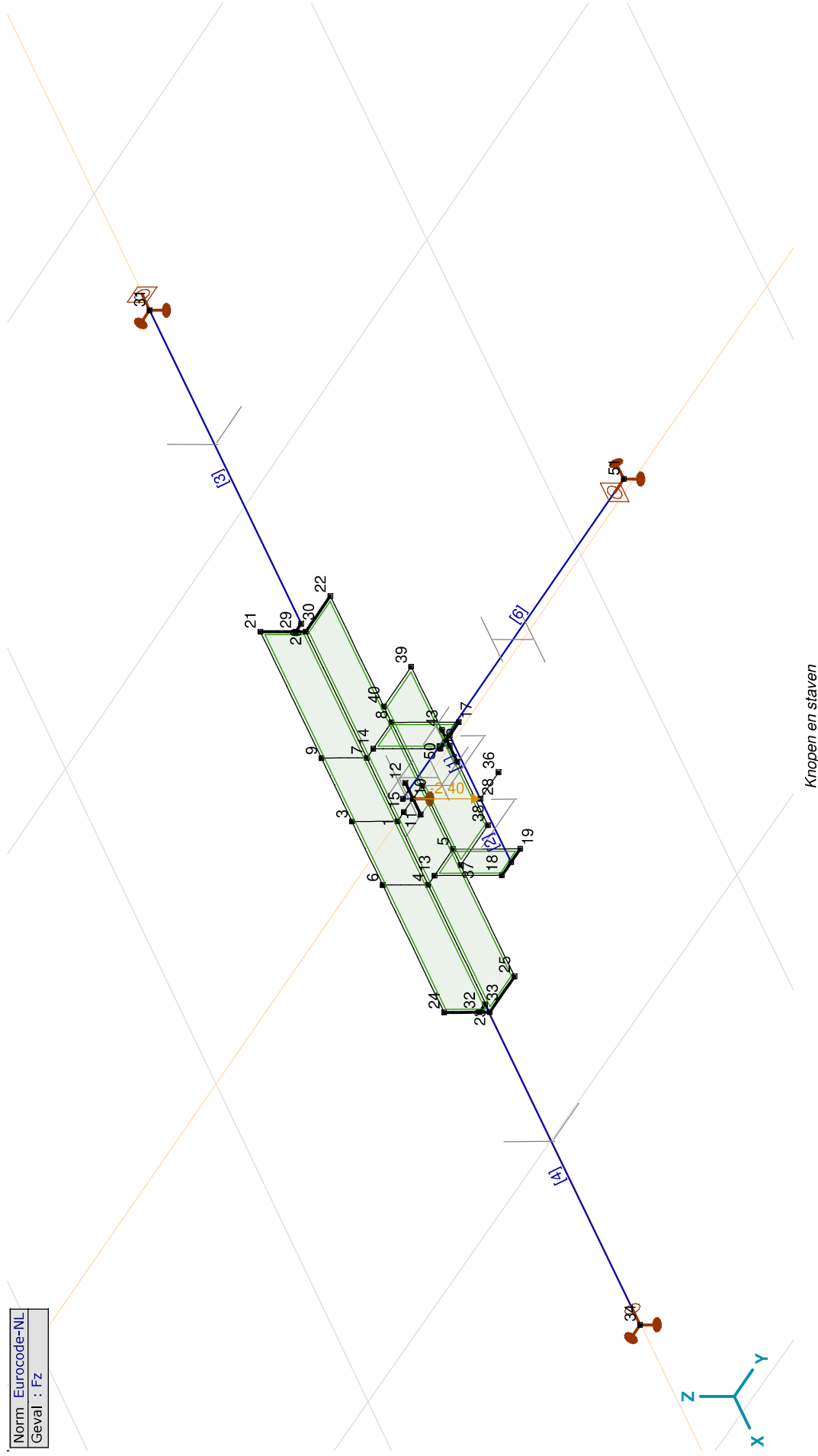





**Project:**

Constructeur: DNV GL - Energy  
 Model: Post aan onderrand.axs

6-3-2021

Pag. 6

**Profielen**

Naam	Tekening	Productie	Vorm	h [mm]	b [mm]	tw [mm]	tf [mm]	r <sub>1</sub> [mm]	r <sub>2</sub> [mm]	r <sub>3</sub> [mm]	A <sub>x</sub> [mm <sup>2</sup> ]	A <sub>y</sub> [mm <sup>2</sup> ]	A <sub>z</sub> [mm <sup>2</sup> ]	I <sub>x</sub> [mm <sup>4</sup> ]	I <sub>y</sub> [mm <sup>4</sup> ]	I <sub>z</sub> [mm <sup>4</sup> ]
1 U 200		Gewalst	U	200,0	75,0	8,5	11,5	11,5	6,0	0	3218,52	931,26	1555,63	121078,6	1,9E+07	1477534,0
2 L 150X150X14		Gewalst	L	150,0	150,0	14,0	14,0	16,0	8,0	0	4031,60	1760,18	1776,16	278959,0	8453331,0	8453331,0
3 HE 140 A		Gewalst	I	133,0	140,0	5,5	8,5	12,0	0	0	3142,19	2147,66	704,86	81932,8	1E+07	3893251,0

Naam	I <sub>yz</sub> [mm <sup>4</sup> ]	I <sub>l</sub> [mm <sup>4</sup> ]	I <sub>2</sub> [mm <sup>4</sup> ]	α [°]	I <sub>ω</sub> [mm <sup>6</sup> ]	W <sub>1,el,t</sub> [mm <sup>3</sup> ]	W <sub>1,el,b</sub> [mm <sup>3</sup> ]	W <sub>2,el,t</sub> [mm <sup>3</sup> ]	W <sub>2,el,b</sub> [mm <sup>3</sup> ]	W <sub>1,pl</sub> [mm <sup>3</sup> ]	W <sub>2,pl</sub> [mm <sup>3</sup> ]	i <sub>y</sub> [mm]	i <sub>z</sub> [mm]	H <sub>y</sub> [mm]	H <sub>z</sub> [mm]
1 U 200	0	1,9E+07	1477534,0	0	8,9E+09	191091,8	191091,8	26935,4	73344,2	227755,3	51850,6	77,1	21,4	75,0	200,0
2 L 150X150X14	-4971153,0	1,3E+07	3482178,0	45,00	4,2E+08	126567,2	126567,2	65498,4	58536,3	200109,5	102485,0	45,8	45,8	150,0	150,0
3 HE 140 A	0	1E+07	3893251,0	0	1,5E+10	155382,8	155382,8	55617,9	55617,9	173525,9	84852,6	57,3	35,2	140,0	133,0

Naam	y <sub>G</sub> [mm]	z <sub>G</sub> [mm]	y <sub>s</sub> [mm]	z <sub>s</sub> [mm]	S.p.
1 U 200	20,1	100,0	-38,7	0	8
2 L 150X150X14	42,1	42,1	-33,9	-33,9	4
3 HE 140 A	70,0	66,5	0	0	9

**Naam:** Doorsnede naam; **Productieproces:** Vorm; **Profiel:** h: Doorsnede hoogte; b: Doorsnede breedte; tw: Lijfdikte; tf: Flensdikte; r<sub>1</sub>, r<sub>2</sub>, r<sub>3</sub>: Afrondingswaarde; **Ax:** Doorsnede-oppervlak; **Ay:** Afschuiwingsoppervlak; **Ix:** Torsie draagheidsmoment; **Iy, Iz:** Bui draagheidsmoment; **Iyz:** Centrifugaal draagheidsmoment; **I<sub>l</sub>, I<sub>2</sub>:** Hoofdbuig draagheidsmoment; **α:** Hoofdrichtingen; **I<sub>ω</sub>:** Krommingsconstante; **W<sub>1,el</sub>, W<sub>2,el</sub>, W<sub>1,pl</sub>, W<sub>2,pl</sub>:** Elasticiteit modulus; **i<sub>y</sub>, i<sub>z</sub>:** Traagheidsstraal; **H<sub>y</sub>:** Afmeting in lokale Y-richting; **H<sub>z</sub>:** Afmeting in lokale Z-richting; **y<sub>s</sub>:** Y-coördinaat van het zwaartepunt; **z<sub>s</sub>:** Z-coördinaat van het zwaartepunt; **y<sub>s</sub>:** Y-coördinaat van het afschuiwingsmiddelpunt (torsie); **z<sub>s</sub>:** Z-coördinaat van het afschuiwingsmiddelpunt (torsie); **S.p.:** Spanningspunten;

**Project:**

Constructeur: DNV GL - Energy  
 Model: Post aan onderrand.axs

## Domeinen

Element type	Materiaal	Ref <sub>x</sub>	Ref <sub>z</sub>	Dikte [mm]	k <sub>buiging</sub> []	k <sub>torsie</sub> []	k <sub>afschuiving</sub> []	Oppervlakte [m <sup>2</sup> ]	Gat	Mesh
1	Schaal S 355	Auto	Auto	12				0,020	-	✓
2	Schaal S 355	Auto	Auto	12				0,020	-	✓
3	Schaal S 355	Auto	Auto	14				0,162	-	✓
4	Schaal S 355	Auto	Auto	14				0,162	-	✓
5	Schaal S 355	Auto	Auto	14				0,075	-	✓

**Element type:** Plaatslement type; **Ref<sub>x</sub>:** Referentie voor lokale X-richting; **Ref<sub>z</sub>:** Referentie voor lokale Z-richting; **k<sub>buiging</sub>:** Buigsterkte coefficient; **k<sub>torsie</sub>:** Torsiesterkte coefficient; **k<sub>afschuiving</sub>:** Dwarskrachsterkte coefficient; **Oppervlakte:** Domein oppervlakte;  
**Gat:** Aantal gaten in domein; **Mesh:** Gegeneerde mesh;

## Knooppopleggingen

Knoop	X [m]	Y [m]	Z [m]
1	31	-1,600	0,030
2	34	1,600	0,030
3	51	0	1,285
4	10	0	0,085

Knoop	Type	Naam <sub>x</sub>	K <sub>x</sub> [kN/m]	K <sub>xv</sub> [kN/m]	Naam <sub>y</sub>	K <sub>y</sub> [kN/m]	K <sub>yv</sub> [kN/m]	Naam <sub>z</sub>	K <sub>z</sub> [kN/m]	K <sub>xv</sub> [kN/m]	Naam <sub>xx</sub>	K <sub>xy</sub> [kNm/rad]	K <sub>xyv</sub> [kNm/rad]
1	31	Glob.	Vast - translatie	1E+10	Vast - translatie	1E+10	1E+10	Vast - translatie	1E+10	1E+10	Vast - rotatie	1E+10	1E+10
2	34	Glob.	—	—	Vast - translatie	1E+10	1E+10	Vast - translatie	1E+10	1E+10	Vast - rotatie	1E+10	1E+10
3	51	Glob.	Vast - translatie	1E+10	Vast - translatie	1E+10	1E+10	Vast - translatie	1E+10	1E+10	—	—	—
4	10	Glob.	—	—	—	—	—	Vast - translatie	1E+10	1E+10	—	—	—

Knoop	Naam <sub>yy</sub>	K <sub>yy</sub> [kNm/rad]	K <sub>yyv</sub> [kNm/rad]	Naam <sub>zz</sub>	K <sub>zz</sub> [kNm/rad]	K <sub>zzv</sub> [kNm/rad]
1	—	—	—	—	—	—
2	—	—	—	—	—	—
3	Vast - rotatie	1E+10	1E+10	—	—	—
4	—	—	—	—	—	—

**Knoop:** Ondersteunde knoop; **Type:** Opleggingstype; **Naam<sub>x</sub>:** Naam van de veereigenschappen; **K<sub>x</sub>:** Initiële stijfheid; **K<sub>xv</sub>:** Trillingsstijfheid; **Naam<sub>y</sub>:** Naam van de veereigenschappen; **K<sub>y</sub>:** Initiële stijfheid; **K<sub>yv</sub>:** Trillingsstijfheid; **Naam<sub>z</sub>:** Naam van de veereigenschappen; **K<sub>z</sub>:** Initiële stijfheid; **K<sub>zv</sub>:** Trillingsstijfheid; **Naam<sub>xx</sub>:** Naam van de veereigenschappen; **K<sub>xy</sub>:** Trillingsstijfheid; **Naam<sub>yy</sub>:** Naam van de veereigenschappen; **K<sub>yy</sub>:** Trillingsstijfheid; **Naam<sub>zz</sub>:** Naam van de veereigenschappen; **K<sub>zz</sub>:** Trillingsstijfheid; **K<sub>zzv</sub>:** Trillingsstijfheid;

**Project:**

Constructeur: DNV GL - Energy

Model: **Post aan onderrand.axs**

**Mx: Knooppbelastingen**

Richting	$F_x$ [kN]	$F_y$ [kN]	$F_z$ [kN]	$M_x$ [kNm]	$M_y$ [kNm]	$M_z$ [kNm]
28	0	1,80	0	2,40	0	0

$F_x, F_y, F_z$ : Belastingkracht component:  $M_x, M_y, M_z$ : Belastingmoment component:

Norm Eurocode-NL  
Geval : Mx

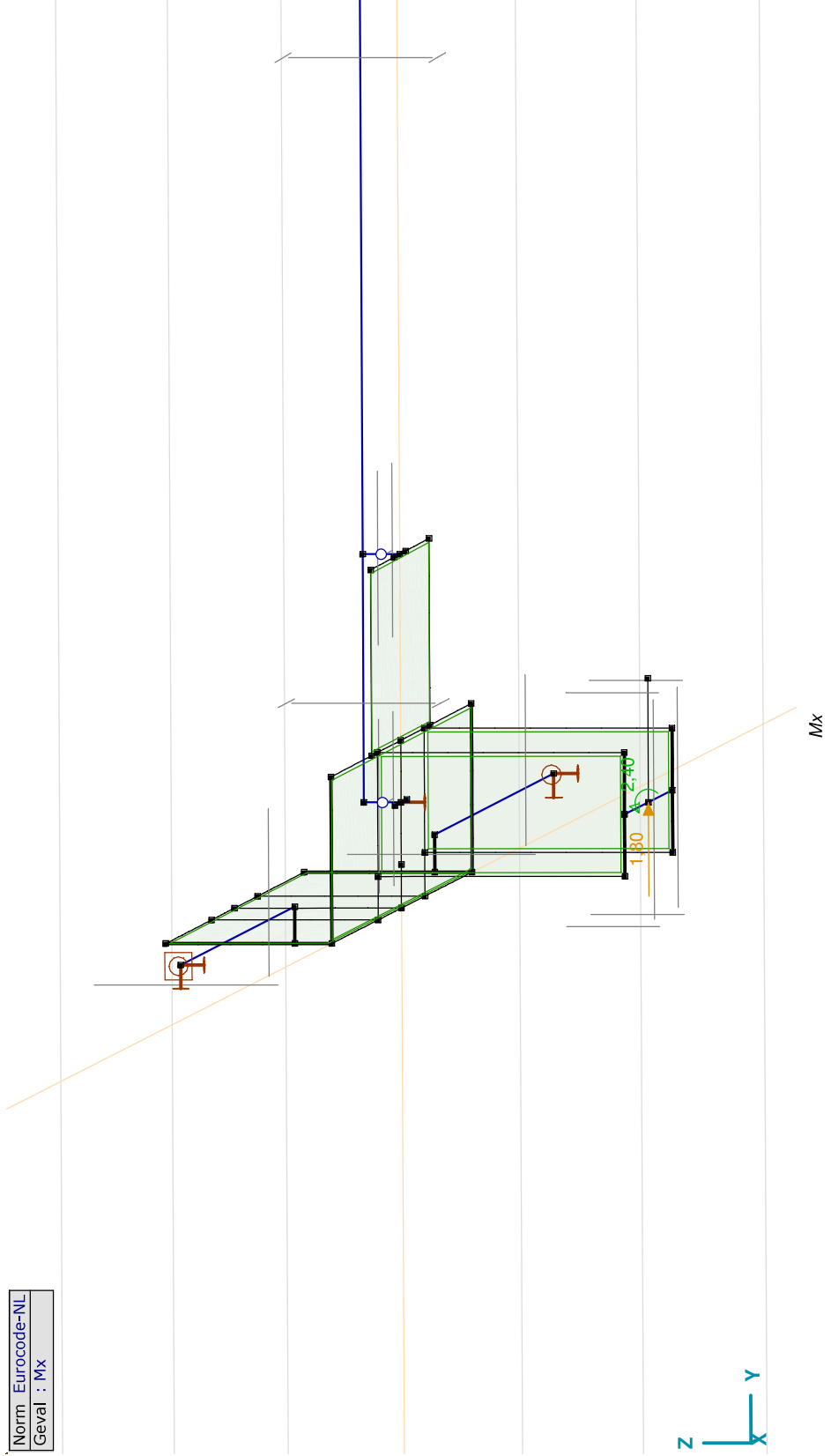

**Project:**  
 Constructeur: DNV GL - Energy  
 Model: Post aan onderrand.axs

My: Knoopbelastingen

Richting	$F_x$ [kN]	$F_y$ [kN]	$F_z$ [kN]	$M_x$ [kNm]	$M_y$ [kNm]	$M_z$ [kNm]
28 Global	-3,00	0	0	0	5,80	0

$F_x, F_y, F_z$ : Belastingkracht component;  $M_x, M_y, M_z$ : Belastingmoment component;

Norm Eurocode-NL  
 Geval : My

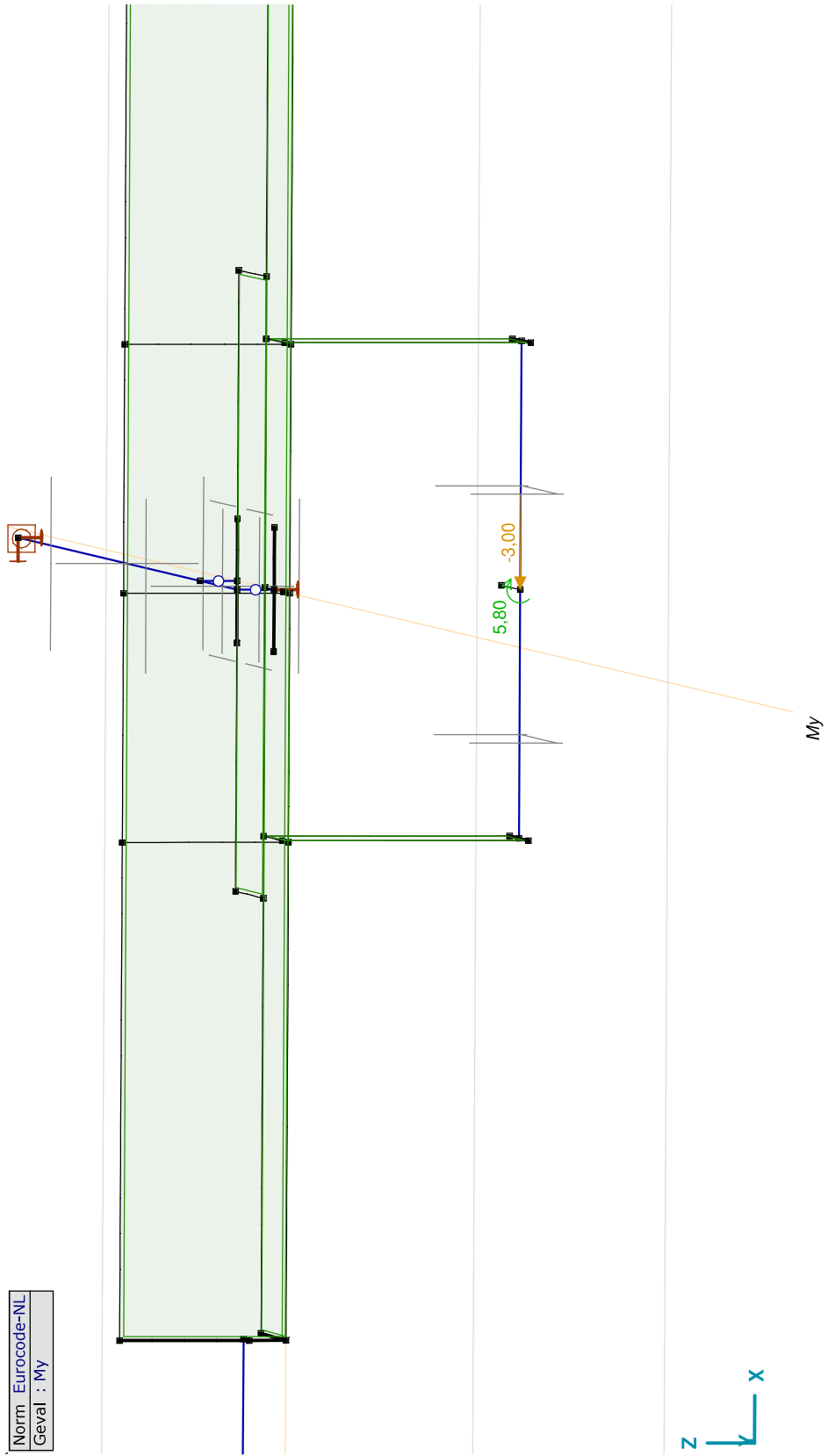

**Project:**

Constructeur: DNV GL - Energy

Model: Post aan onderrand.axs

**Fz: Knoopbelastingen**

Richting	$F_x$ [kN]	$F_y$ [kN]	$F_z$ [kN]	$M_x$ [kNm]	$M_y$ [kNm]	$M_z$ [kNm]
28 Global	0	0	-2,40	0	0	0

**Fx, Fy, Fz:** Belastingkracht component: **Mx, My, Mz:** Belastingmoment component:

Norm Eurocode-NL  
Geval : Fz

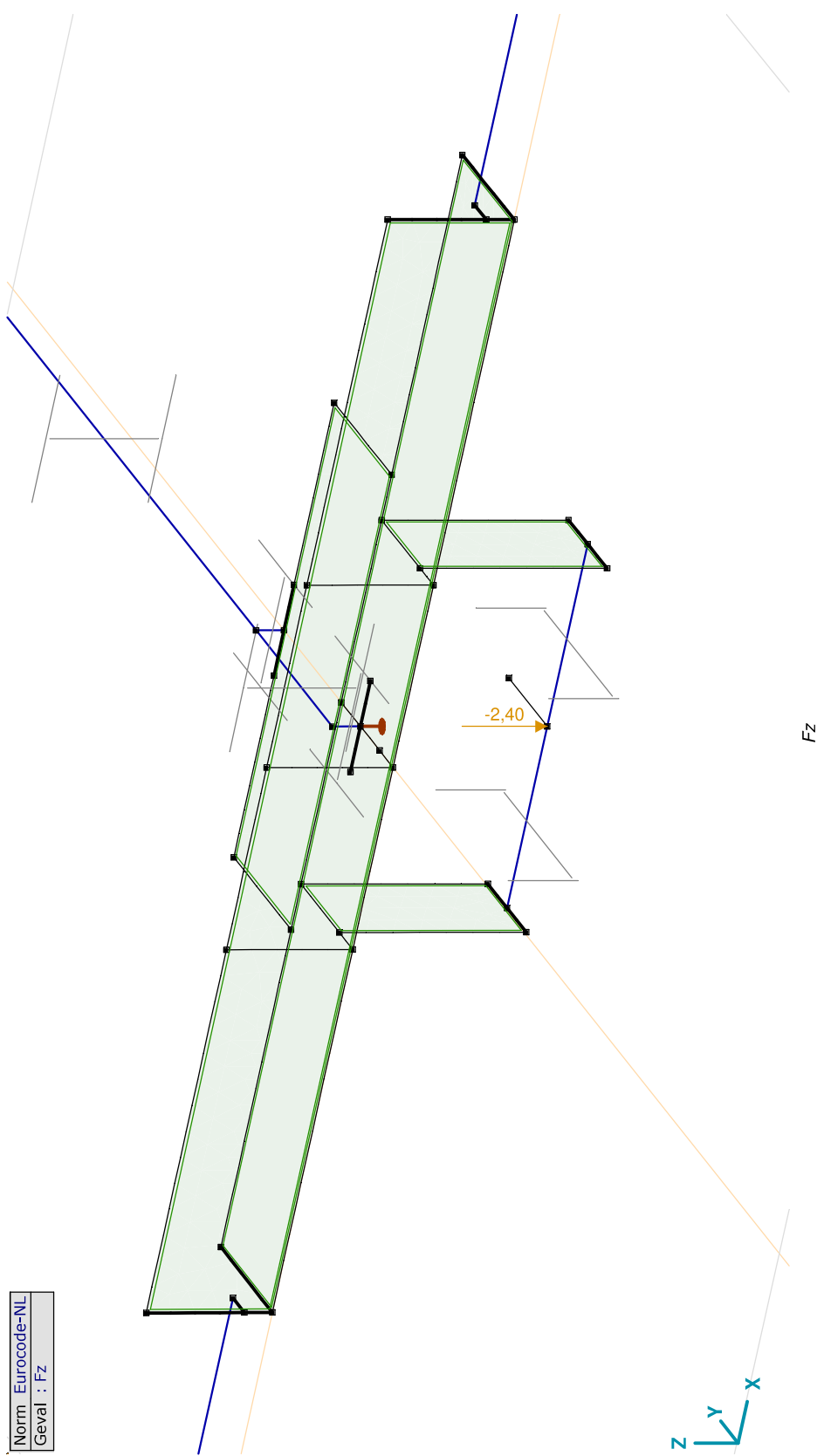

**Project:**  
 Constructeur: DNV GL - Energy  
 Model: Post aan onderrand.axs

N: Knooppbelastingen

	Richting	$F_x$ [kN]	$F_y$ [kN]	$F_z$ [kN]	$M_x$ [kNm]	$M_y$ [kNm]	$M_z$ [kNm]
34	Global	-600,00	0	0	0	0	0

$F_x, F_y, F_z$ : Belastingkracht component;  $M_x, M_y, M_z$ : Belastingmoment component;

Norm Eurocode-NL  
 Geval : N

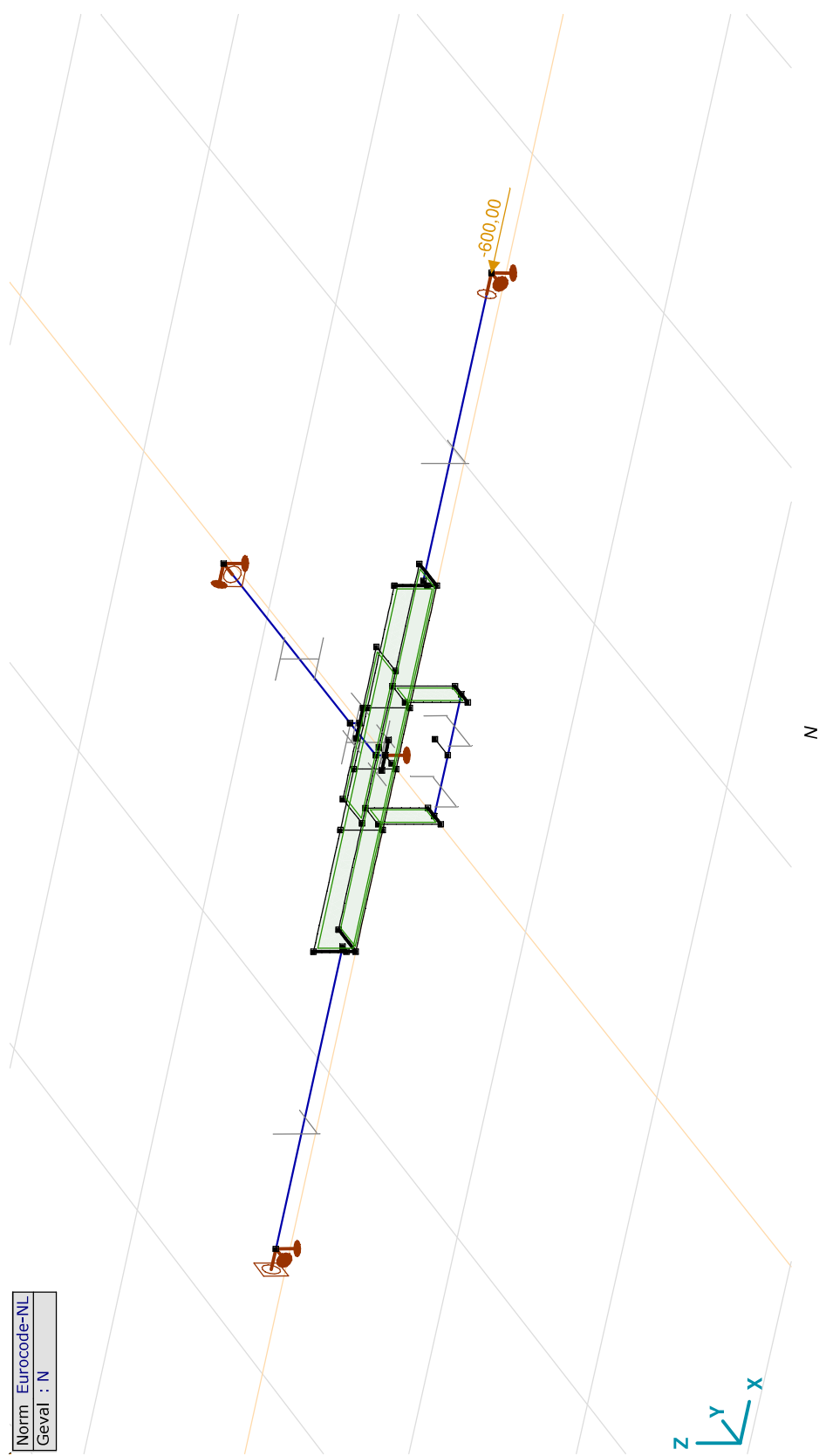



**Project:**

Constructeur: DNV GL - Energy

Model: **Post aan onderrand.axs**

6-3-2021

Pag. 12

## Gebruiker gedefinieerde belastingcombinaties uit belastinggevallen

	<i>Naam</i>	<i>Type</i>	<i>Mx</i>	<i>My</i>	<i>Fz</i>	<i>N</i>	<i>Commentaar</i>
1	Co #1	UGT	1,00	0	1,00	1,00	
2	Co #2	UGT	0	1,00	1,00	1,00	
3	Co #3	UGT	-1,00	0	1,00	1,00	
4	Co #4	UGT	0	-1,00	1,00	1,00	
5	Co #5	UGT	0,71	0,71	1,00	1,00	
6	Co #6	UGT	-0,71	-0,71	1,00	1,00	

Naam: Naam belastingcombinatie; Type: Type belastingcombinatie; **Mx**, **My**, **Fz**, **N**: Factor;



**Project:**  
 Constructeur: DNV GL - Energy  
 Model: Post aan onderstrand.axs

Norm	Lineaire berekening
Geval	Eurocode-NL
Omhullende	: Omhullende Min,Max
E (P)	: 2,64E-9
E (W)	: 2,64E-9
E (Eq)	: 2,76E-7
Comp.	: My [kNm]

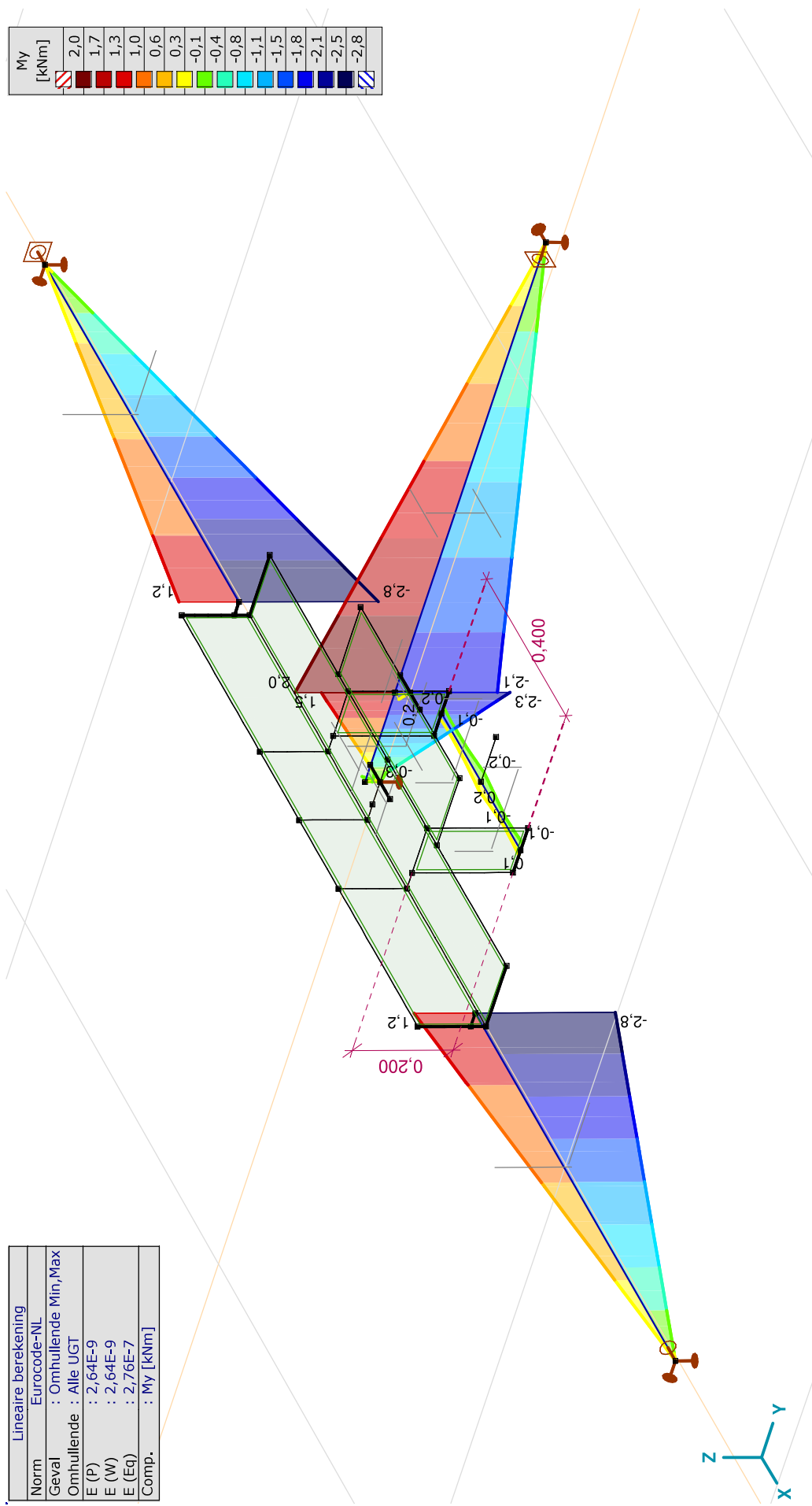
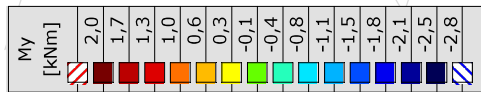

[1], Lineair, Omhullende (Alle UGT), My, Lijnen (gevuld)



**Project:**  
 Constructeur: DNV GL - Energy  
 Model: Post aan onderstrand.axs

Lineaire berekening	
Norm	Eurocode-NL
Geval	: Omhullende Min,Max
Omhullende	: Alle UGT
E (P)	: 2,64E-9
E (W)	: 2,64E-9
E (Eq)	: 2,76E-7
Comp.	: Vz [kN]

Vz [kN]
9,0
7,6
6,2
4,8
3,3
1,9
0,5
-1,0
-2,4
-3,8
-5,2
-6,7
-8,1
-9,5
-11,0

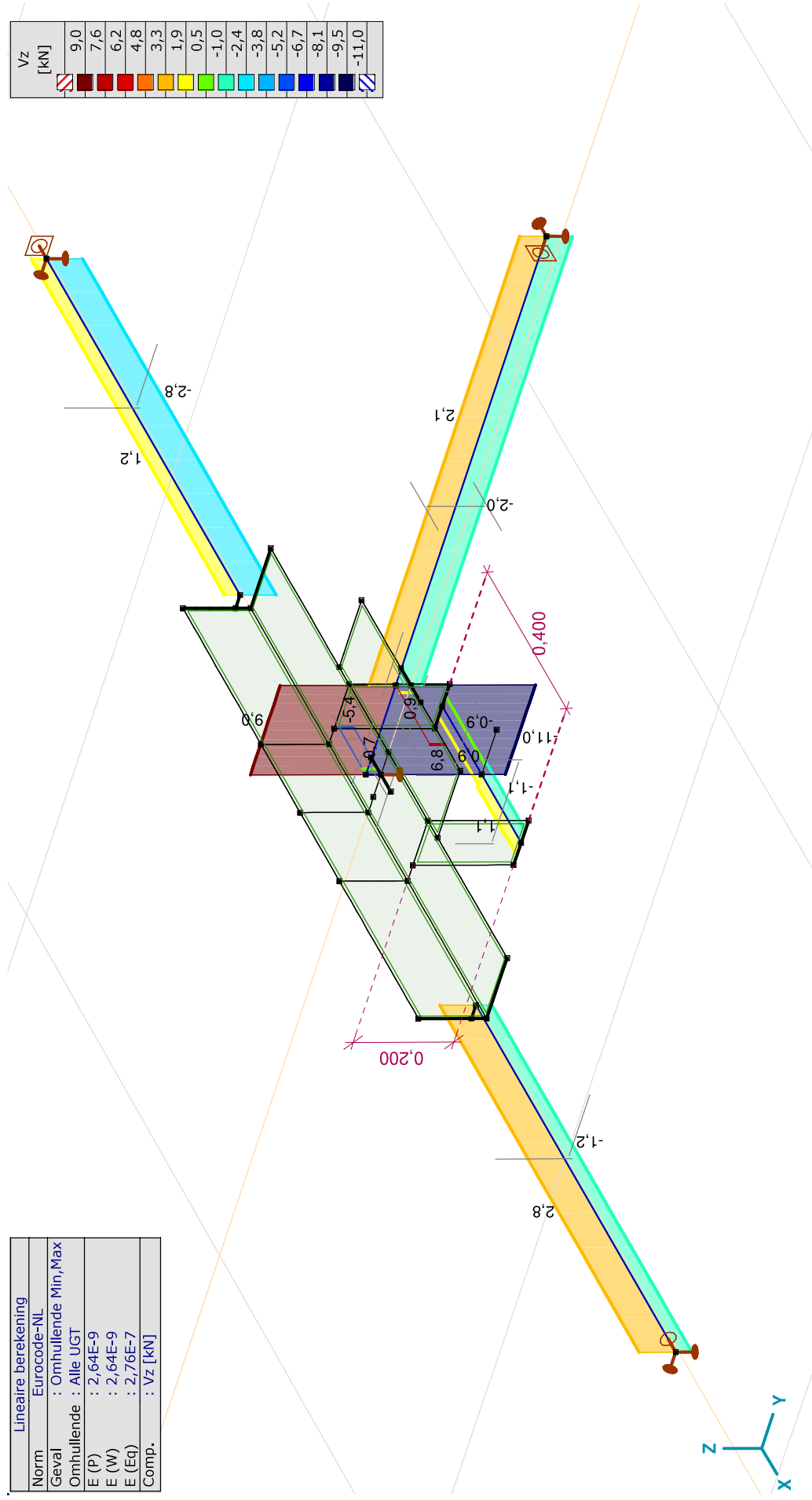

[!] Lineair, Omhullende (Alle UGT), Vz, Lijnen (gevuld)









**Project:**  
 Constructeur: DNV GL - Energy  
 Model: Post aan onderrand.axs

Lineaire berekening	
Norm	Eurocode-NL
Geval	: Co #2
E (P)	: 2,64E-9
E (W)	: 2,64E-9
E (Eq)	: 2,76E-7
Comp.	: eR [mm]

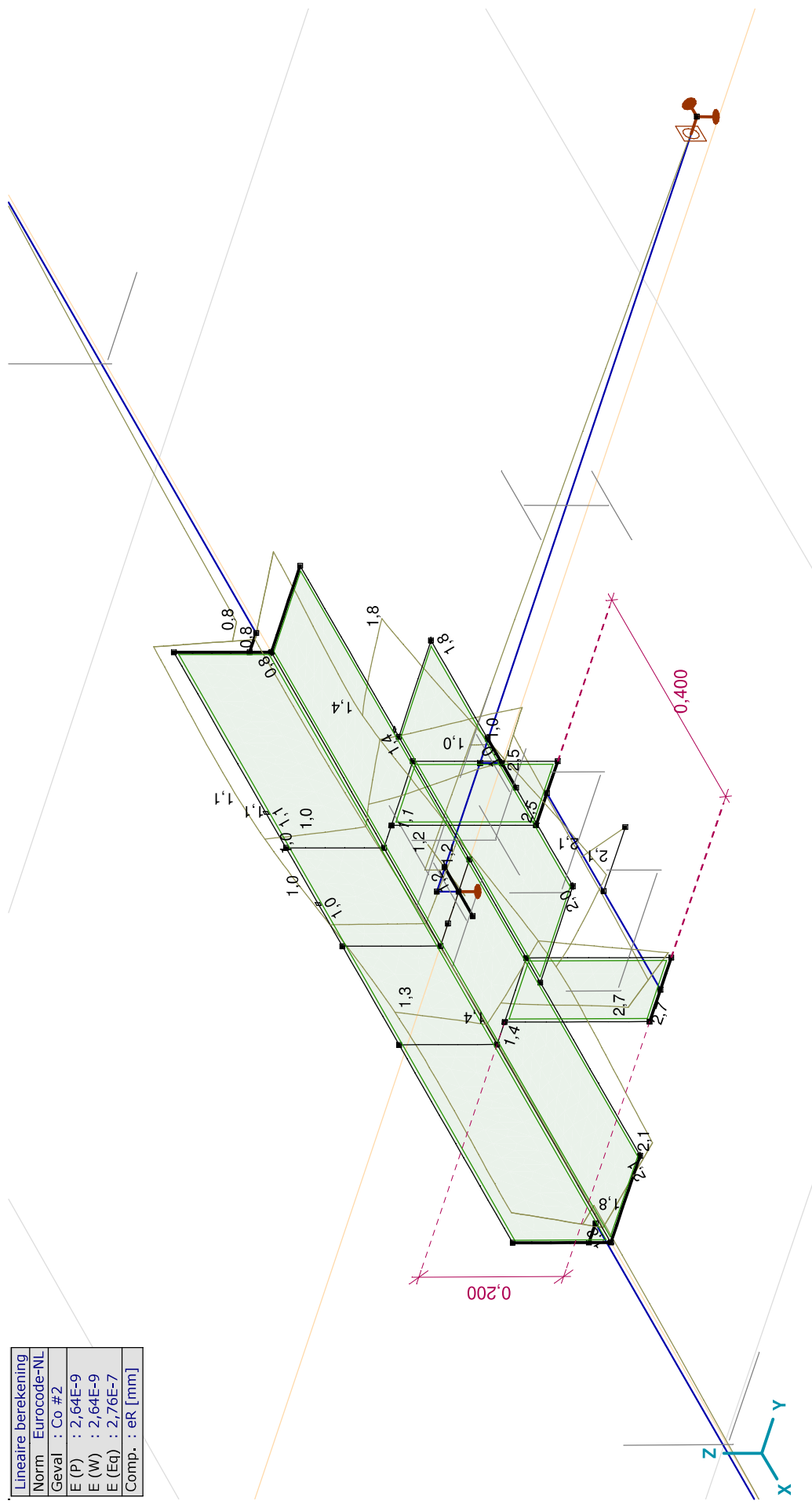

[I], Lineair, Co #2 (UGT), eR, Lijnen



**Project:**  
 Constructeur: DNV GL - Energy  
 Model: Post aan onderrand.axs

Lineaire berekening	
Norm	Eurocode-NL
Geval	: Co #4
E (P)	: 2,64E-9
E (W)	: 2,64E-9
E (Eq)	: 2,76E-7
Comp.	: eR [mm]

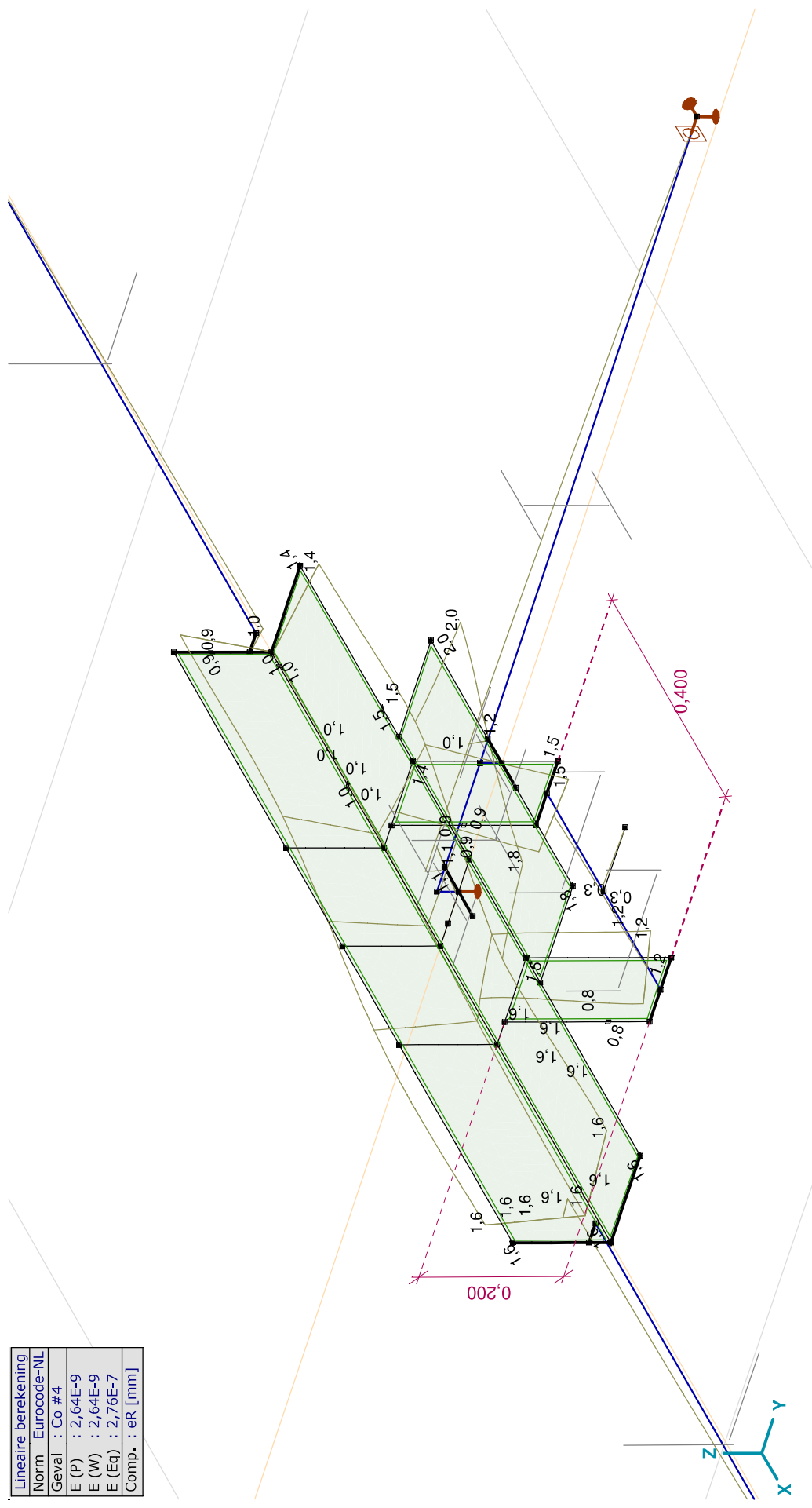

[I], Lineair, Co #4 (UGT), eR, Lijnen





**Project:**  
 Constructeur: DNV GL - Energy  
 Model: Post aan onderrand.axs

Lineaire berekening	
Norm	Eurocode-NL
Geval	: Co #1
E (P)	: 2,64E-9
E (W)	: 2,64E-9
E (Eq)	: 2,76E-7
Comp.	: SVM T [N/mm <sup>2</sup> ]

SVM T [N/mm <sup>2</sup> ]	
355,0	
329,8	
304,6	
279,4	
254,3	
229,1	
203,9	
178,7	
153,5	
128,3	
103,2	
78,0	
52,8	
27,6	
2,4	

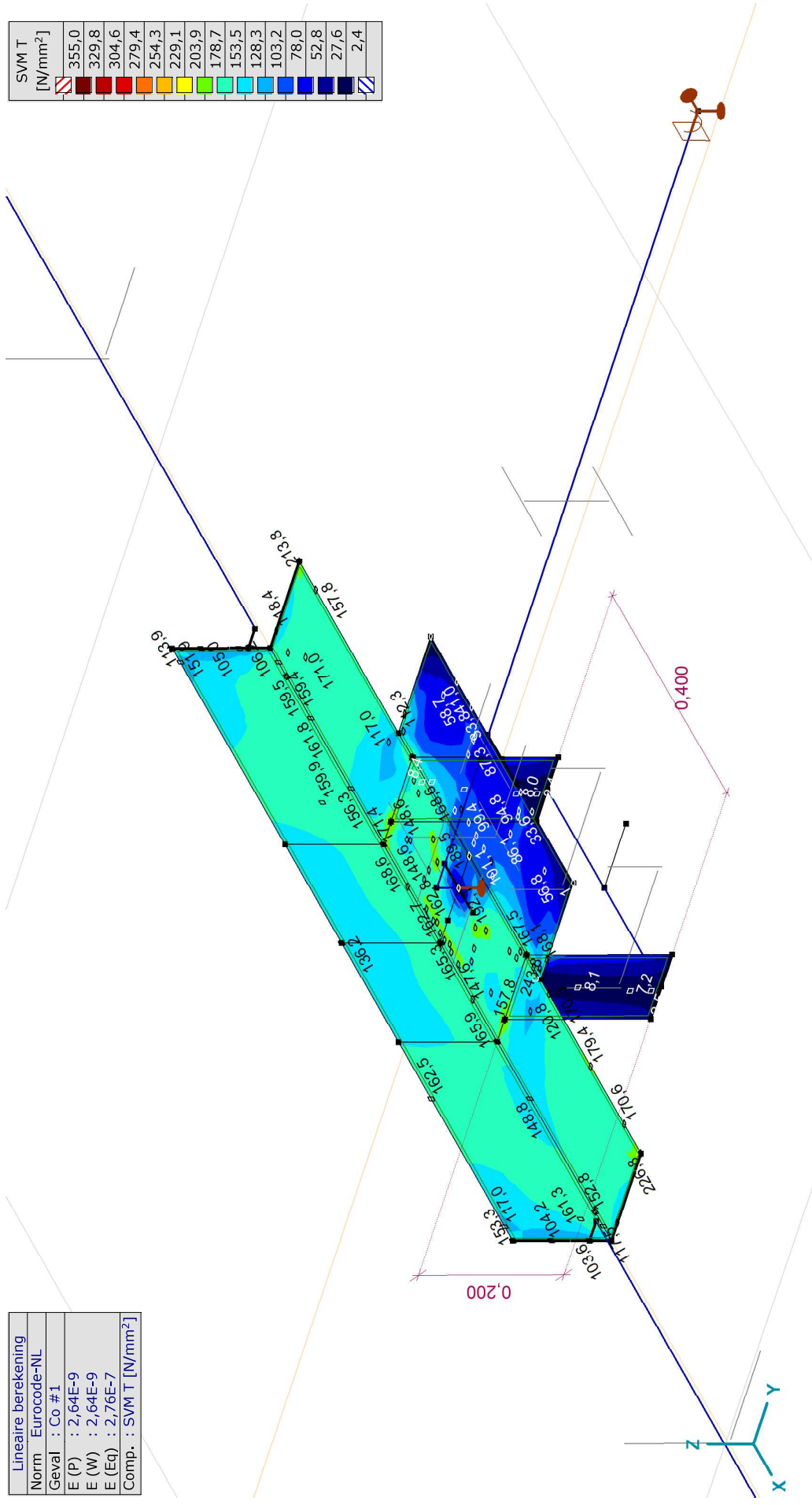

[I], Lineair, Co #1 (UGT), SVM T, Kleuren 2D

**Project:**  
 Constructeur: DNV GL - Energy  
 Model: Post aan onderrand.axs

Lineaire berekening	
Norm	Eurocode-NL
Geval	: Co #2
E (P)	: 2,64E-9
E (W)	: 2,64E-9
E (Eq)	: 2,76E-7
Comp.	: SVM T [N/mm <sup>2</sup> ]

SVM T [N/mm <sup>2</sup> ]	
355,0	
329,8	
304,6	
279,4	
254,3	
229,1	
203,9	
178,7	
153,5	
128,3	
103,2	
78,0	
52,8	
27,6	
2,4	

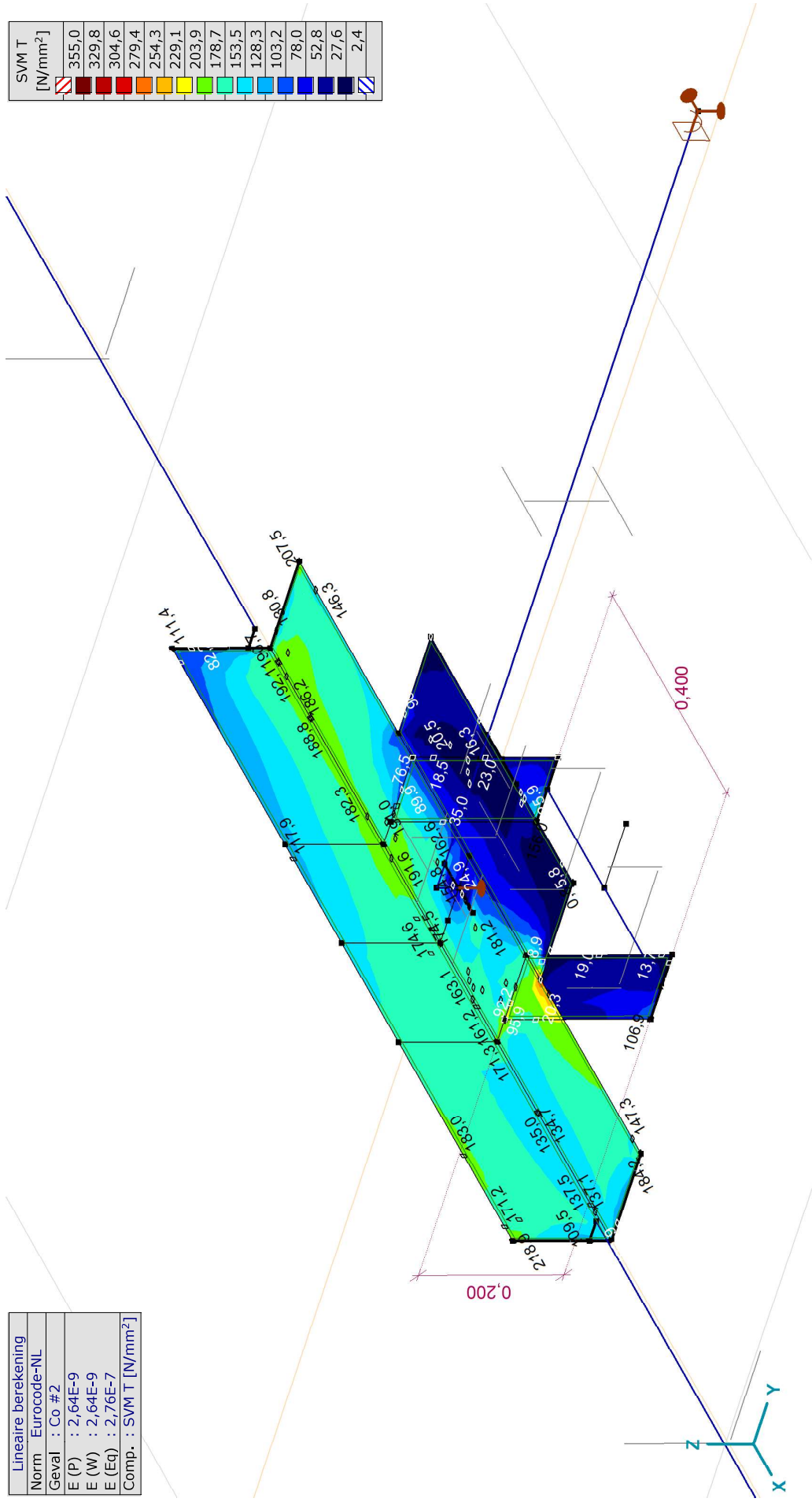

[I], Lineair, Co #2 (UGT), SVM T, Kleuren 2D



**Project:**  
 Constructeur: DNV GL - Energy  
 Model: Post aan onderrand.axs

Lineaire berekening
Norm Eurocode-NL
Geval : Co #3
E (P) : 2,64E-9
E (W) : 2,64E-9
E (Eq) : 2,76E-7
Comp. : SVM T [N/mm <sup>2</sup> ]

SVM T [N/mm <sup>2</sup> ]
355,0
329,8
304,6
279,4
254,3
229,1
203,9
178,7
153,5
128,3
103,2
78,0
52,8
27,6
2,4

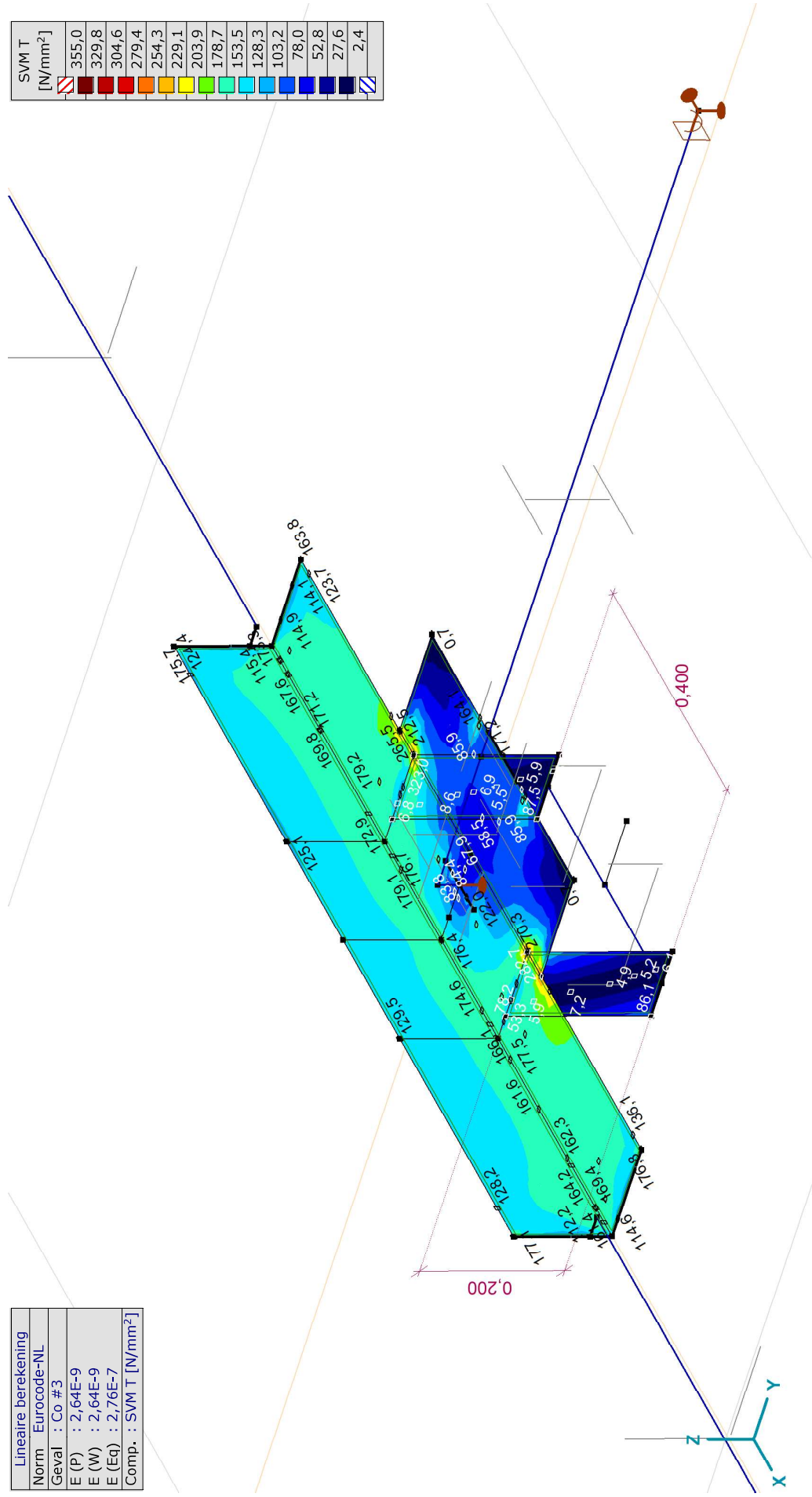

[I], Lineair, Co #3 (UGT), SVM T, Kleuren 2D



**Project:**  
 Constructeur: DNV GL - Energy  
 Model: Post aan onderrand.axs

Lineaire berekening	
Norm	Eurocode-NL
Geval	: Co #4
E (P)	: 2,64E-9
E (W)	: 2,64E-9
E (Eq)	: 2,76E-7
Comp.	: SVM T [N/mm <sup>2</sup> ]

SVM T [N/mm <sup>2</sup> ]	
355,0	[Red diagonal lines]
329,8	[Dark red]
304,6	[Red]
279,4	[Orange-red]
254,3	[Orange]
229,1	[Yellow-orange]
203,9	[Yellow]
178,7	[Light green]
153,5	[Green]
128,3	[Light blue-green]
103,2	[Light blue]
78,0	[Blue]
52,8	[Dark blue]
27,6	[Very dark blue]
2,4	[Dark blue with diagonal lines]

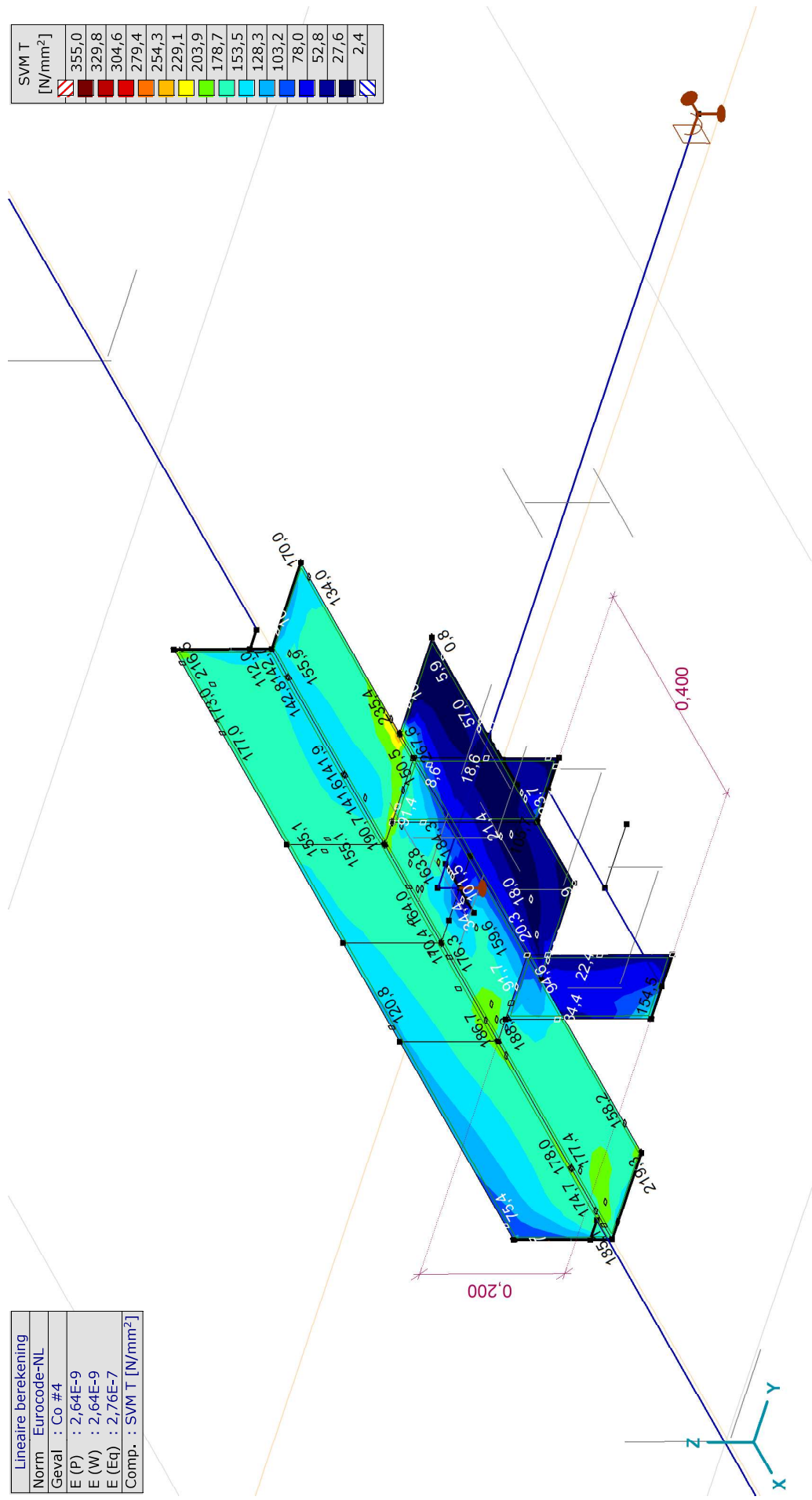

[I], Lineair, Co #4 (UGT), SVM T, Kleuren 2D

**Project:**  
 Constructeur: DNV GL - Energy  
 Model: Post aan onderrand.axs

Lineaire berekening	
Norm	Eurocode-NL
Geval	: Co #5
E (P)	: 2,64E-9
E (W)	: 2,64E-9
E (Eq)	: 2,76E-7
Comp.	: SVM T [N/mm <sup>2</sup> ]

SVM T [N/mm <sup>2</sup> ]	
355,0	[Red diagonal hatching]
329,8	[Dark red]
304,6	[Red]
279,4	[Orange-red]
254,3	[Orange]
229,1	[Yellow-orange]
203,9	[Yellow]
178,7	[Light green]
153,5	[Green]
128,3	[Light blue-green]
103,2	[Light blue]
78,0	[Blue]
52,8	[Dark blue]
27,6	[Very dark blue]
2,4	[Dark blue with diagonal hatching]

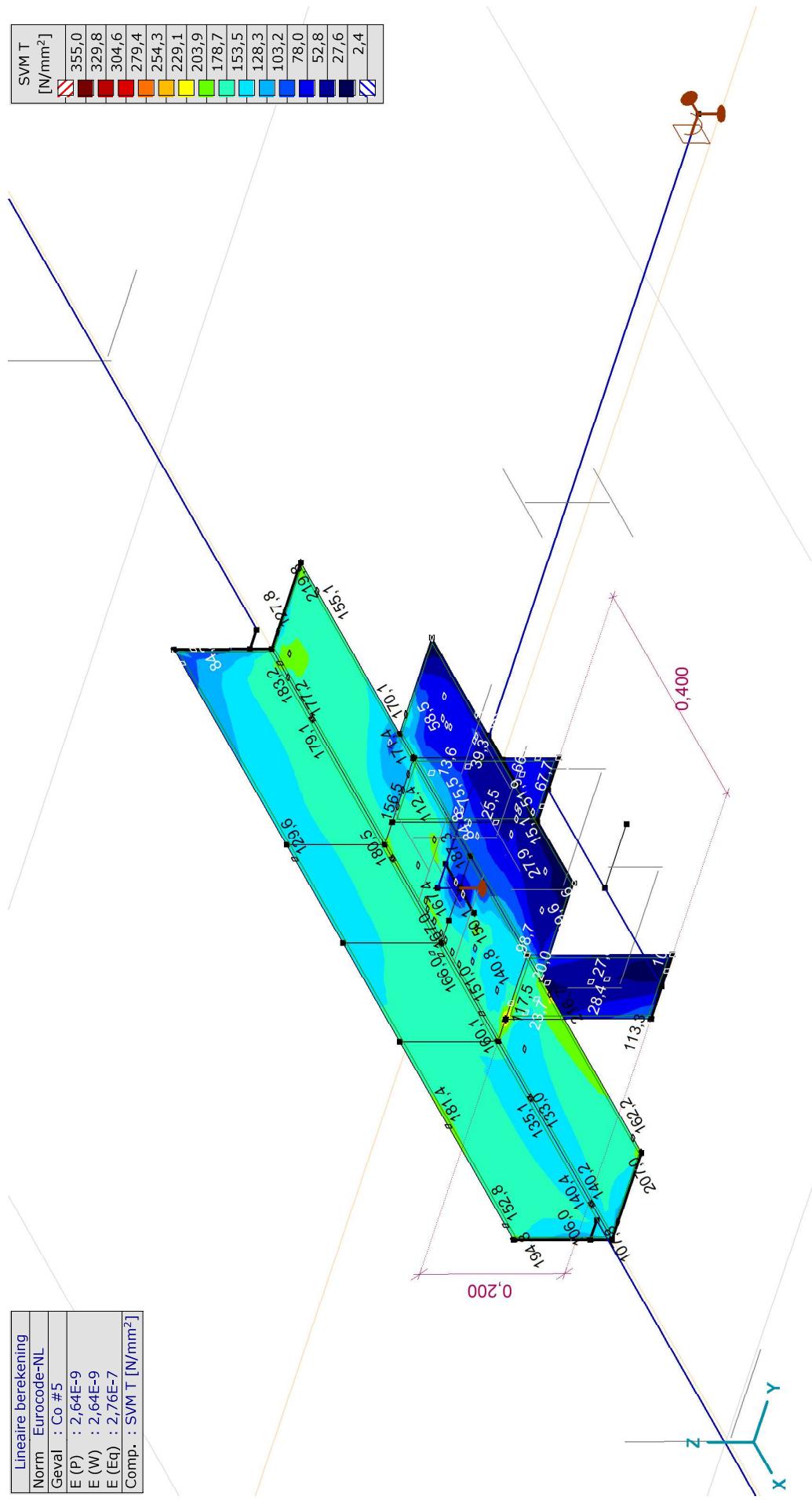

[I], Lineair, Co #5 (UGT), SVM T, Kleuren 2D



**Project:**  
 Constructeur: DNV GL - Energy  
 Model: Post aan onderstrand.axs

Lineaire berekening	
Norm	Eurocode-NL
Geval	: Omhullende Min,Max
Omhullende	: Alle UGT
E (P)	: 2,64E-9
E (W)	: 2,64E-9
E (Eq)	: 2,76E-7
Comp.	: SVM B [N/mm <sup>2</sup> ]

SVM B [N/mm <sup>2</sup> ]
299,0
277,7
256,4
235,1
213,7
192,4
171,1
149,7
128,4
107,1
85,7
64,4
43,1
21,8
0,4

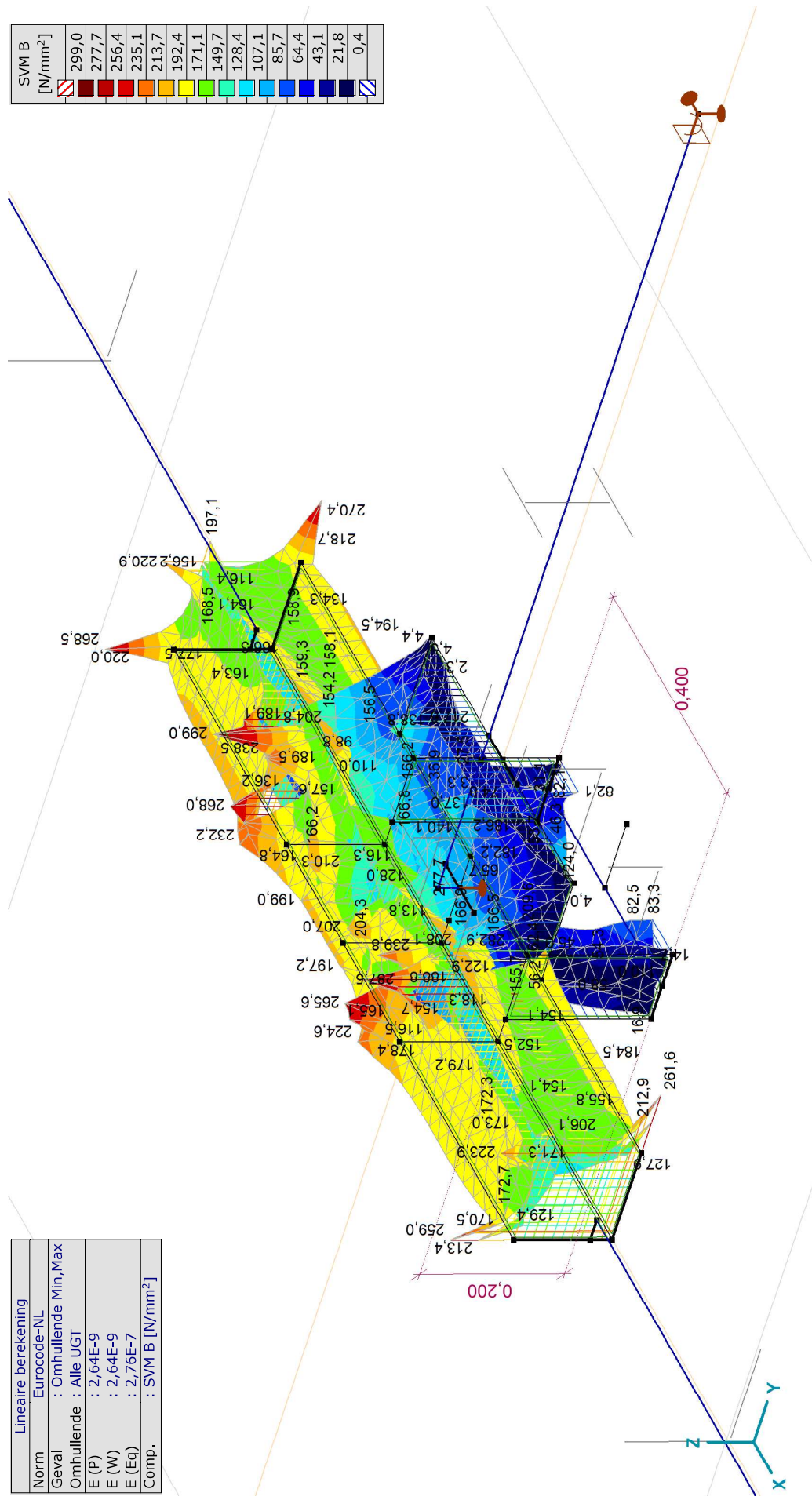

[[J], Lineair, Omhullende (Alle UGT), SVM B, Iso vlakken 3D



**Project:**  
 Constructeur: DNV GL - Energy  
 Model: Post aan onderstrand.axs

Lineaire berekening	
Norm	Eurocode-NL
Geval	: Omhullende Min,Max
Omhullende	: Alle UGT
E (P)	: 2,64E-9
E (W)	: 2,64E-9
E (Eq)	: 2,76E-7
Comp.	: SVM C [N/mm <sup>2</sup> ]

SVM C [N/mm <sup>2</sup> ]
229,8
213,4
197,1
180,7
164,4
148,0
131,7
115,3
99,0
82,6
66,3
49,9
33,6
17,2
0,9

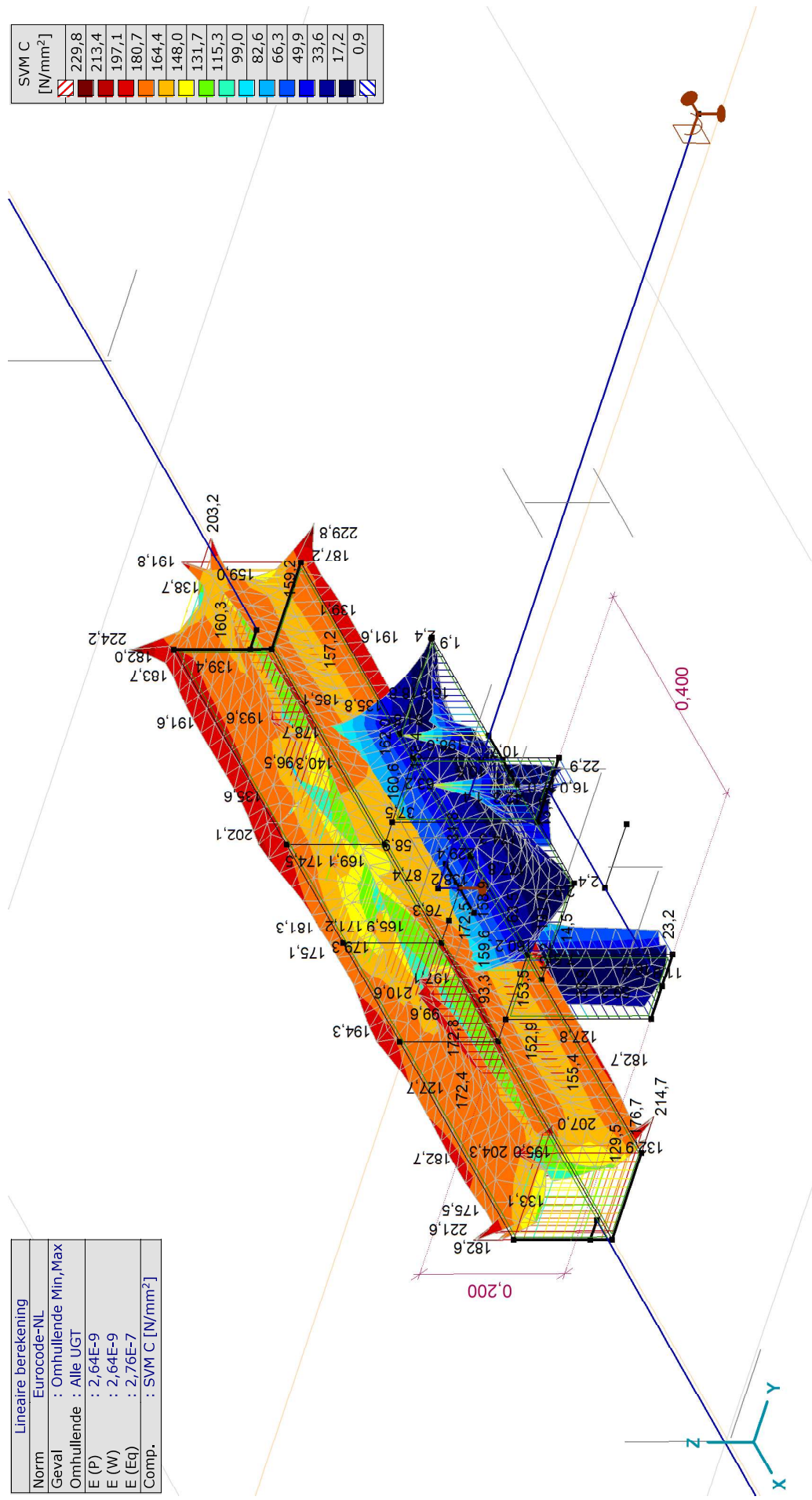

[[J], Lineair, Omhullende (Alle UGT), SVM C, Iso vlakken 3D



**Project:**

Constructeur: DNV GL - Energy

Model: Post aan onderrand.axs

6-3-2021

Pag. 34

## Vlakspanningen [Lineair, Omhullende (Alle UGT ) ]

Knoop	C	min. max.	Geval	Oppervlak	Pos.	Sxx [N/mm <sup>2</sup> ]	Syy [N/mm <sup>2</sup> ]	Szz [N/mm <sup>2</sup> ]	Sxy [N/mm <sup>2</sup> ]	Sxz [N/mm <sup>2</sup> ]	Syz [N/mm <sup>2</sup> ]	SVM [N/mm <sup>2</sup> ]	S1 [N/mm <sup>2</sup> ]	S2 [N/mm <sup>2</sup> ]	aS [°]
Ext.															
39	SVM	min	Co #5	Sch 174	B	0,4	0,4	0	-0,1	0	0	0,4	0,5	0,3	-60,05
5		max	Co #3	Sch 1	T	49,7	281,3	0	-110,4	0	0	322,8	325,5	5,6	-68,18
8		max	Co #3	Sch 65	T	48,6	282,4	0	109,4	0	0	323,0	325,6	5,4	68,44

**Knoop:** Index; **C:** Extreme component; **min, max.:** Extreme type; **Geval:** Belastinggeval van de extreme; **Oppervlak:** Vlak behorend bij knoop; **Pos.:** Punt voor spanningsberekening; **Sxx:** Normalspanning in lokale x-richting; **Syy:** Normalspanning in lokale y-richting; **Szz:** Normalspanning in lokale z-richting; **Sxy, Syz:** Draai-/Schuifspanning; **Sxz, Syz:** Draai-/Schuifspanning; **SVM:** Von Mises spanning; **S1, S2:** Primaire spanning 1; **S2:** Primaire spanning 2; **aS:** Richting primaire spanning;

**Project:**  
 Constructeur: DNV GL - Energy  
 Model: Post aan onderstrand.axs

Norm	Lineaire berekening
Geval	Eurocode-NL
Omhullende	: Omhullende Min,Max
E (P)	: 2,64E-9
E (W)	: 2,64E-9
E (Eq)	: 2,76E-7
Comp.	: S;x:minmax [N/mm <sup>2</sup> ]

S;x:minmax [N/mm <sup>2</sup> ]	
96,3	
74,9	
53,6	
32,3	
11,0	
-10,3	
-31,6	
-53,0	
-74,3	
-95,6	
-116,9	
-138,2	
-159,5	
-180,8	
-202,2	

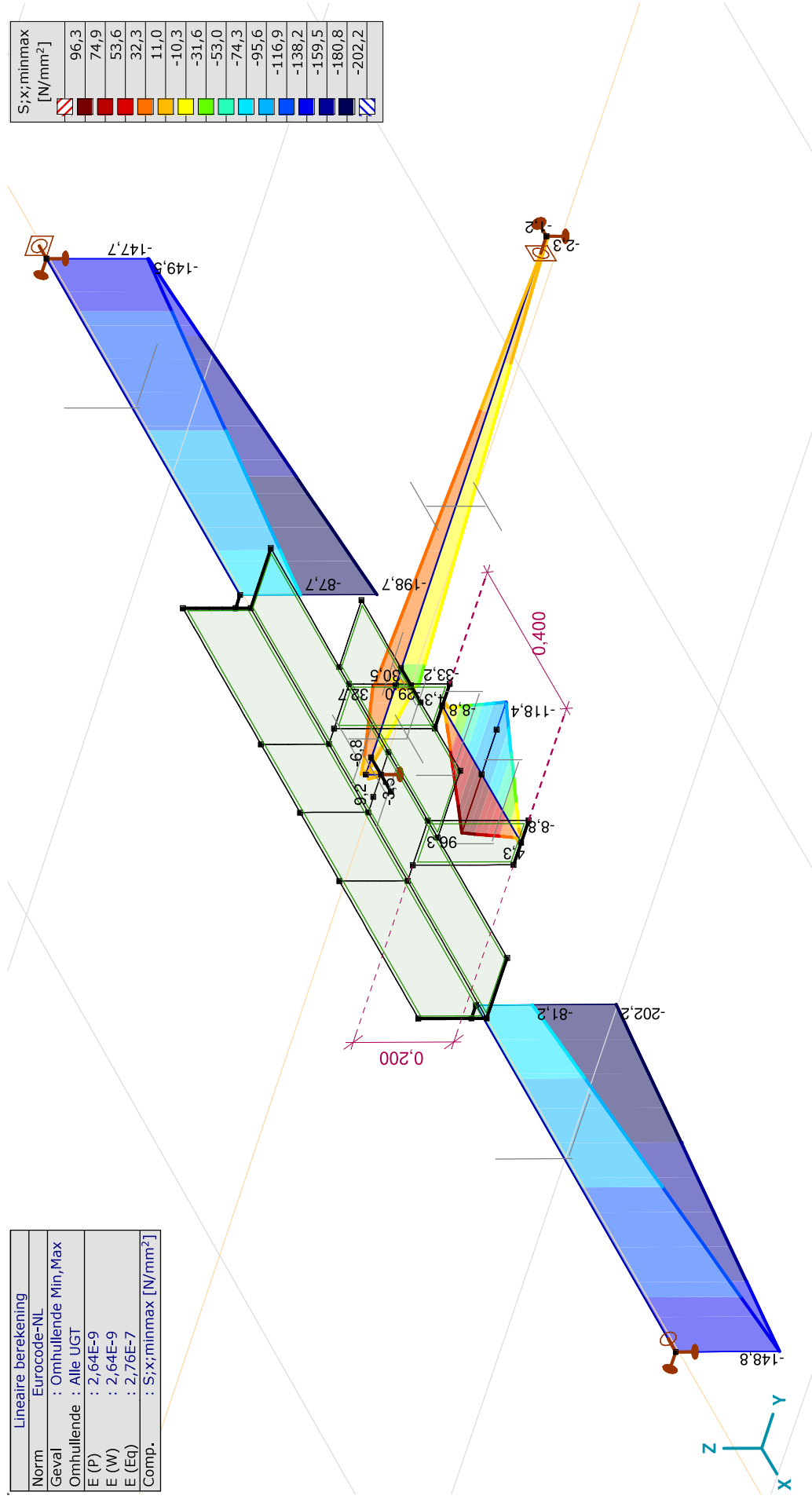

[I]. Lineair, Omhullende (Alle UGT), S;x:minmax, Lijnen (gevuld)



**Project:**

Constructeur: DNV GL - Energy  
 Model: **Post aan onderrand.axs**

6-3-2021

Pag. 36

## Staafspanningen [Lineair, Omhullende (Alle UGT )]

Ext.	Prof.	Doorsnede naam	C	min. max.	Geval	Pos. [m]	Knoop	S:x:min [N/mm <sup>2</sup> ]	S:x:max [N/mm <sup>2</sup> ]	Vmin [N/mm <sup>2</sup> ]	Vmax [N/mm <sup>2</sup> ]	Somin [N/mm <sup>2</sup> ]	Somax [N/mm <sup>2</sup> ]	V,y:gem [N/mm <sup>2</sup> ]	V,z:gem [N/mm <sup>2</sup> ]
6	3	HE 140 A	Somax	min	Co #2	1,000	(51)	-1,8	-1,8	0,4	0,7	1,9	2,1	-0,1	0
4	2	L 150X150X14	Somax	max	Co #2	0	(33)	-202,2	-81,2	0	5,8	81,8	202,4	0,7	0,7

**Prof.:** Profiel; **C:** Extreme component; **min. max.:** Extreme type; **Geval:** Belastinggeval van de extreme; **Pos.:** Lokale X-positie van de doorsnede op de staaf; **Sx:min:** Doorsnede minimum normaalspanning; **Sx:max:** Doorsnede maximum normaalspanning;  
**Vmin:** Doorsnede minimum afschuifspanning; **Vmax:** Doorsnede maximum afschuifspanning; **Somin:** Doorsnede minimum Von Mises spanning; **Somax:** Doorsnede maximum Von Mises spanning; **V,y:gem:** Afschuifspanning in lokale Y-richting;  
**V,z:gem:** Afschuifspanning in lokale Z-richting;

**Project:**

Constructeur: DNV GL - Energy  
 Model: Post aan onderrand.axs

## Interne krachten knooppogging [Linear, Omhullende (Alle UGT )]

	Knoop	X [m]	Y [m]	Z [m]	Type	C	min. max.	Geval	Rx [kN]	Ry [kN]	Rz [kN]	Rr [kN]	Rxx [kNm]	Ryy [kNm]	Rrr [kNm]	αR		
1	31	-1,600	0,030	0,030	Glob.	Rx	min	Co #2	-602,8	-2,7	1,2	602,8	0,1			0,1	494,075	
							max	Co #4	-595,6	-2,1	-2,8	595,6	-0,1			0,1	-209,474	
							min	Co #2	-602,8	-2,7	1,2	602,8	0,1			0,1	494,075	
							max	Co #4	-595,6	-2,1	-2,8	595,6	-0,1			0,1	-209,474	
							min	Co #4	-595,6	-2,1	-2,8	595,6	-0,1			0,1	-209,474	
							max	Co #2	-602,8	-2,7	1,2	602,8	0,1			0,1	494,075	
2	34	1,600	0,030	0,030	Glob.	Ry	min	Co #4	-3,3	-3,3	1,2	3,6	0,1			0,1	2,696	
							max	Co #2	-2,8	-2,8	-2,8	4,0	-0,1			0,1	-0,977	
							min	Co #2	-2,8	-2,8	-2,8	4,0	-0,1			0,1	-0,977	
							max	Co #4	-3,3	-3,3	1,2	3,6	0,1			0,1	2,696	
							min	Co #4	-1,4	5,5	0	5,6	0			0	-209,038	
							max	Co #2	-0,2	5,5	0	5,5	0			0	-202,439	
3	51	0	1,285	0,030	Glob.	Ry	min	Co #3	-0,8	3,8	-2,1	4,4	0			0	-1,844	
							max	Co #1	-0,8	7,2	2,0	7,5	0			0	3,588	
							min	Co #3	-0,8	3,8	-2,1	4,4	0			0	-1,844	
							max	Co #1	-0,8	7,2	2,0	7,5	0			0	3,588	
							min	Co #1	-0,8	7,2	2,0	7,5	0			0	3,588	
							max	Co #3	-0,8	3,8	-2,1	4,4	0			0	-1,844	
4	10	0	0,085	0	Glob.	Rz	min	Co #1	-2,1		-2,1	2,1					0	
							max	Co #3	0,6		0,6							0
Ext.																		
1	31	-1,600	0,030	0,030	Glob.	Rx	min	Co #2	-602,8	-2,7	1,2	602,8	0,1			0,1	494,075	
							max	Co #2	-0,2	5,5	0	5,5	0			0	-202,439	
							min	Co #4	-602,8	-2,7	1,2	602,8	0,1			0,1	494,075	
3	51	0	1,285	0,030	Glob.	Ry	min	Co #4	-0,8	3,3	1,2	3,6	0,1			0,1	2,696	
							max	Co #1	-0,8	7,2	2,0	7,5	0			0	3,588	
							min	Co #1	-0,8	7,2	2,0	7,5	0			0	3,588	
2	34	1,600	0,030	0,030	Glob.	Rz	min	Co #4	-595,6	-2,1	-2,8	595,6	-0,1			0,1	-209,474	
							max	Co #1	-0,8	7,2	2,0	7,5	0			0	3,588	
							min	Co #4	-595,6	-2,1	-2,8	595,6	-0,1			0,1	-209,474	
3	51	0	1,285	0,030	Glob.	Rz	min	Co #1	-0,8	7,2	2,0	7,5	0			0	3,588	
							max	Co #4	-595,6	-2,1	-2,8	595,6	-0,1			0,1	-209,474	
							min	Co #1	-0,8	7,2	2,0	7,5	0			0	3,588	

**Knoop:** Ondersteunde knoop; **Type:** Opleggingstype; **C:** Extremer component; **min, max:** Extremer geval van de extreme; **Rx:** X-component opleggingreactiekracht; **Ry:** Y-component opleggingreactiekracht; **Rz:** Z-component opleggingreactiekracht; **Rr:** Resulterende opleggingreactiekracht; **Rxx:** X-component opleggingreactiemoment; **Ryy:** Y-component opleggingreactiemoment; **Rrr:** Resulterende verticale opleggingreactiekracht / horizontale opleggingreactiekracht;

Project: RLL-TBG  
 Mast: HA+0\_c

**Steel beams in torsion**  
*Calculation of unrestrained beams with eccentric load*

Datum: 2021-02-22  
 Auteur: MRE  
 Versie: 1.1

<b>Load</b>		<b>Beam 1</b>	<b>Beam 2</b>	<b>Beam 3</b>	<b>Beam 4</b>	
Force on insulator		6.88				kN
Angle of insulator (to vertical)		54				°
Horizontal force in direction of Horizontal force	F <sub>h</sub>	5.6				kN
Vertical force	F <sub>v</sub>	4.0				kN
Eccentricity of force (below beam)	e	3375				mm
Torsional moment	T	19.4				kNm
<b>Beams</b>						
Beam length	L	1820				mm
Yield stress	f <sub>y</sub>	355				Mpa
Elastic modulus	E	210000				Mpa
Shear modulus	G	81000				Mpa
Profile		HEB 220				
		HEB220				
Height	h	220				mm
Width	b	220				mm
Web thickness	t <sub>w</sub>	9.5				mm
Flange thickness	t <sub>f</sub>	16.0				mm
Torsional constant	I <sub>t</sub>	77				· 10 <sup>4</sup> mm <sup>4</sup>
Warping constant	I <sub>wa</sub>	295418				· 10 <sup>6</sup> mm <sup>6</sup>
Moment of inertia	I <sub>y</sub>	8091				· 10 <sup>4</sup> mm <sup>4</sup>
	I <sub>z</sub>	2843				· 10 <sup>4</sup> mm <sup>4</sup>
Flange stiffness	I <sub>f</sub> = I <sub>z</sub> / 2 =	1422				mm <sup>3</sup>
Moment of resistance	W <sub>y,el</sub>	736				· 10 <sup>3</sup> mm <sup>3</sup>
	W <sub>z,el</sub>	258				· 10 <sup>3</sup> mm <sup>3</sup>
Torsional bending constant	d	997				mm
	L/d	1.8				
	a	0.5				

**Calculation of second derivative of angular deflection φ'':**

$$\begin{aligned}
 A &= T / (G \cdot I_t \cdot d) = && 3.12E-07 \\
 B &= \sinh(\alpha \cdot L / d) = && 1.04E+00 \\
 C &= \tanh(L/d) = && 9.49E-01 \\
 D &= \cosh(\alpha \cdot L / d) = && 1.45E+00 \\
 F &= \sinh(0.5 \cdot L / d) = && 1.04E+00 \\
 H &= (B / C - D) \cdot F = && -3.61E-01 \\
 X &= A \cdot H = && -1.13E-07 \\
 \\
 Y &= X \cdot G \cdot I_t \cdot d / T = && -3.61E-01 \\
 \phi'' &= Y \cdot T / (G \cdot I_t \cdot d) = && -1.13E-07 \quad \text{rad/mm}^2
 \end{aligned}$$

Project: RLL-TBG  
 Mast: HA+0\_c

### **Steel beams in torsion**

*Calculation of unrestrained beams with eccentric load*

Datum: 2021-02-22

Auteur: MRE

Versie: 1.1

#### **Acting moments:**

$M_{w,Ed} = E \cdot I_r \cdot (h \cdot t_f) \cdot \phi'' / 2 =$	34.3	<i>kNm</i>
$M_{y,Ed} = 1/4 \cdot F \cdot L =$	1.8	<i>kNm</i>
$M_{z,Ed} = 1/4 \cdot F \cdot L =$	2.5	<i>kNm</i>

#### **Capacities of beams:**

$M_{w,Rd} = W_{z,el} \cdot f_y / 2 =$	45.9	<i>kNm</i>
$M_{y,Rd} = W_{y,el} \cdot f_y =$	261.1	<i>kNm</i>
$M_{z,Rd} = W_{z,el} \cdot f_y =$	91.8	<i>kNm</i>

#### **Combined check of beam:**

UC 0,78

#### **Displacements:**

Factor $F_{ed} / F_k$		1.2	
Displacement y-direction	$u_y$	0.02	<i>mm</i>
Relative displacement	rel.	73062	-
Displacement z-direction	$u_z$	0.10	<i>mm</i>
Relative displacement	rel.	18654	-

## APPENDIX F

### Sterkte-coördinatie

In 5.5.1 van het uitgangspuntenrapport is beschreven dat aan sterkte-coördinatie wordt voldaan als de U.C. van de staven in de traverse 10 procentpunt groter is dan de U.C. van de staven in het mastlichaam. Uitgangspunt is belastingcombinatie 5a, geleiderbreuk. In deze Appendix wordt getoetst of de U.C. van de staven in het mastlichaam voldoende laag is ten opzichte van de U.C. van de staven in de traverse.

Aangezien alle masttypen in de groep van combi-hoekmasten dezelfde mastkop delen, wordt enkel masttype HA+0/c getoetst. Mogelijk dat andere typen een hoger of lager worden belast, maar dat levert geen verschil op in de verhouding van uitnutting tussen de verschillende onderdelen.

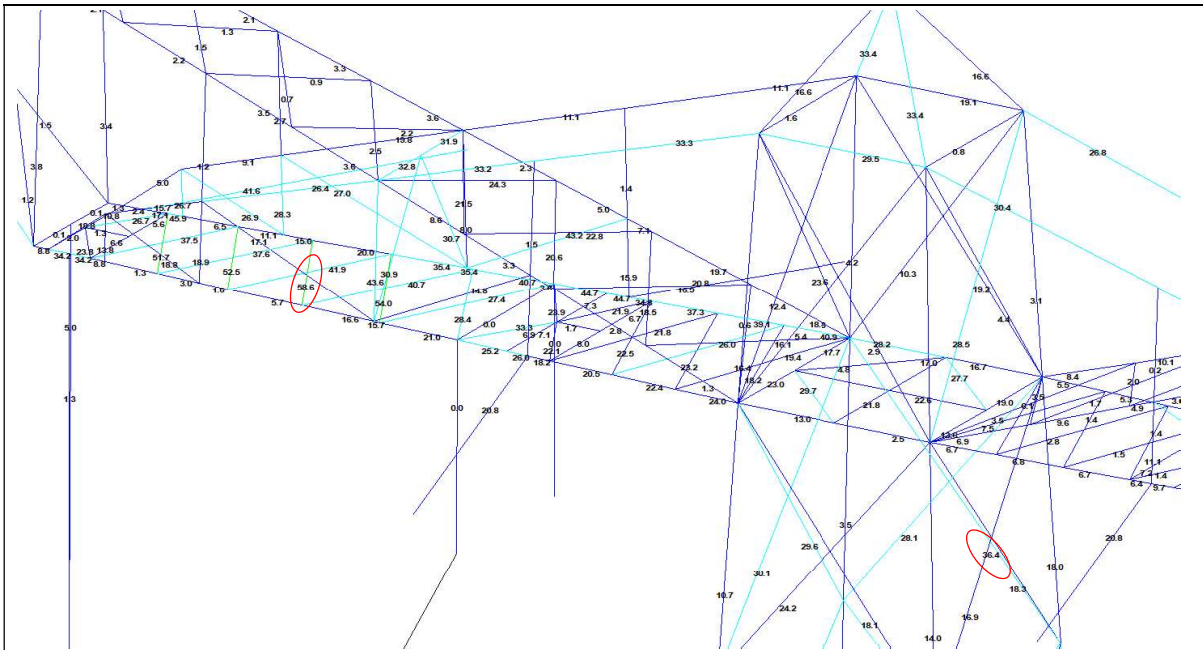

Boventraverse – diagonalen bovenstuk 2:  $58,6 / 36,4 = 1,61 \geq 1,10$  OK.

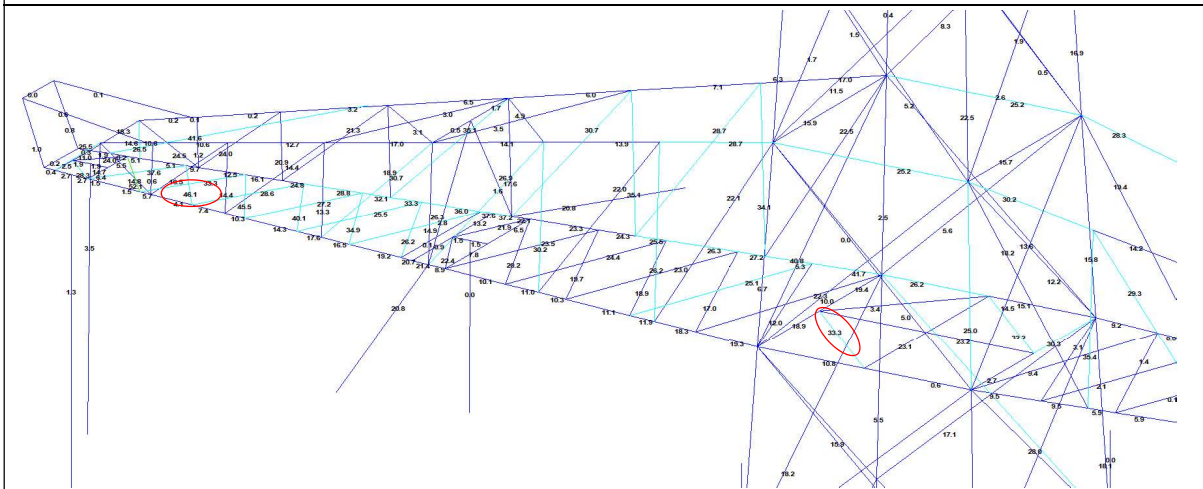

Middentraverse – tussenschot:  $46,1 / 33,3 = 1,38 \geq 1,10$  OK.

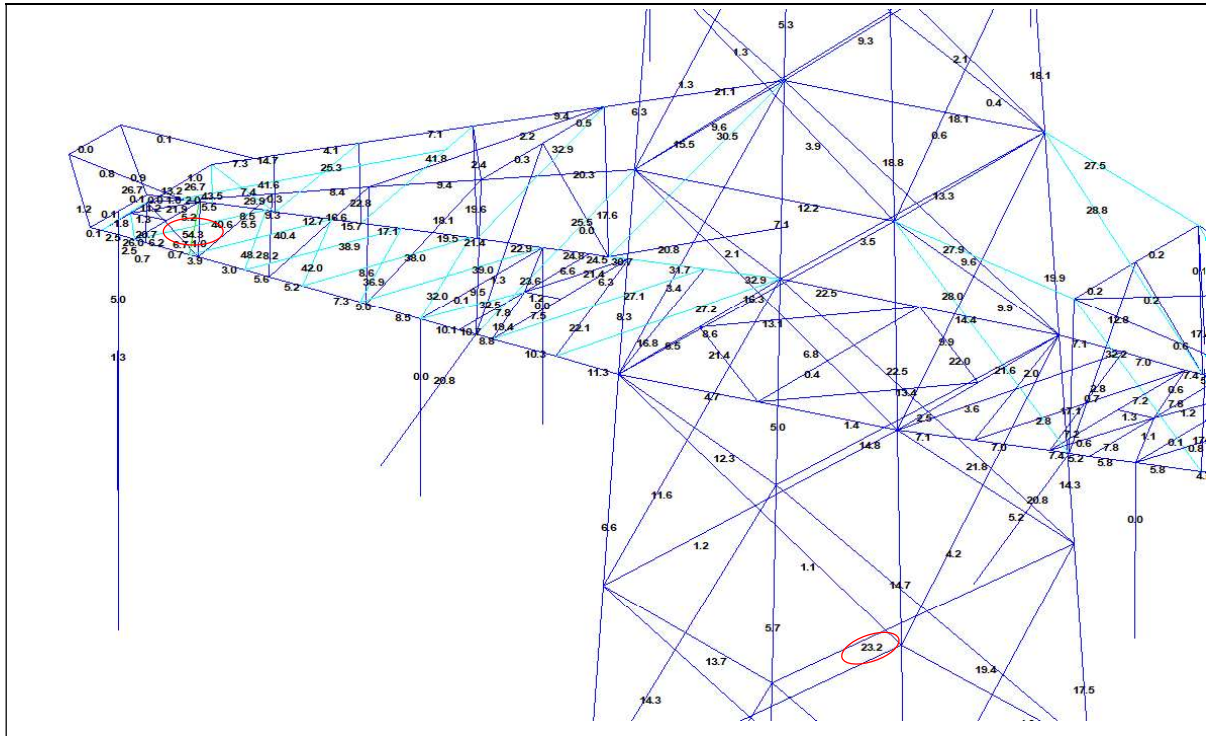

Ondertraverse:  $54,3 / 23,2 = 2,34 \geq 1,10$  OK

## APPENDIX G

### Galloping

#### Uitgangspunten

In het uitgangspuntendocument is beschreven dat wordt uitgegaan van een materiaalfactor voor vermoeiing  $\gamma_{mf} = 1,15$ . Dit komt overeen met de “Safe-life methode” met “Low consequence” van tabel 3.1 van NEN-EN 1993-1-9 of met “Damage tolerant” en “High consequence”.

Assessment method	Consequence of failure	
	Low consequence	High consequence
Damage tolerant	1,00	1,15
Safe life	1,15	1,35

Voor staven met gatverzwakking met bouten in ruime gaten geldt volgens fig. 8.1 van NEN-EN 1993-1-9 categorie 50, met  $m=3$



Voor niet voorgespannen bouten belast op afschuiving geldt volgens fig. 8.1 van NEN-EN 1993-1-9 categorie 100, met  $m=5$ .

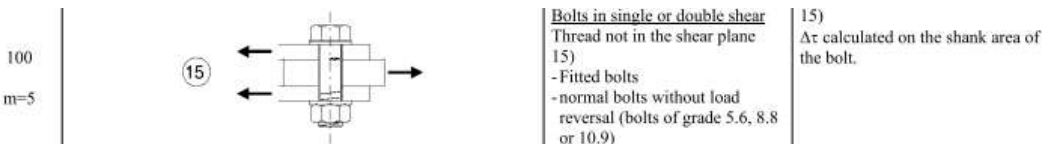

Het belastingspectrum is in de NNA (NEN-EN 50341-2-15) als volgt gedefinieerd.

**Table 4.11/NL.1 Load spectra line galloping for tension supports**

Load spectra line galloping for tension supports		Number of load cycles in 50 years	
Number	Peak-to-peak load	Ice region A	Ice region B
1	2·EDS	7.000	3.000
2	1,5·EDS	36.000	17.000
3	1,0·EDS	125.000	65.000
4	0,5·EDS	482.000	265.000

#### Aanpak

De vier belastingen van 0,5 tot 2,0EDS hebben een vaste onderlinge verhouding. Aangezien het aantal wisselingen zich in het  $m=3$  gebied van de vermoeiingskromme bevindt vanwege  $n < 2 \times 10^6$ , kan een relatie worden afgeleid tussen de grootte van de spanningswissel met bijvoorbeeld 1,0EDS en de spanningswisseling die bij  $2 \times 10^6$  wisselingen op basis van het spectrum nog net toelaatbaar is. Dit staat bekend als de equivalente spanningen methode. Via de factor lambda kan de spanningswisseling worden berekend.

$$\lambda = \left[ \frac{\sum \Delta\sigma_i^m \cdot n_i}{2 \cdot 10^6} \right]^{\frac{1}{m}}$$

Toepassen van de formule voor een spanning van 1 N/mm<sup>2</sup> bij 1,0EDS levert:

Helling Ijsgebied	m=3		m=5	
	A	B	A	B
Wisseling	$\sigma_i^m \times n_i$	$\sigma_i^m \times n_i$	$\sigma_i^m \times n_i$	$\sigma_i^m \times n_i$
2,0EDS	5,60E+04	2,40E+04	2,24E+05	9,60E+04
1,5EDS	1,22E+05	5,74E+04	2,73E+05	1,29E+05
1,0EDS	1,25E+05	6,50E+04	1,25E+05	6,50E+04
0,5EDS	6,03E+04	3,31E+04	1,51E+04	8,28E+03
$\Sigma \sigma_i^m \times n_i$	3,63E+05	1,80E+05	6,37E+05	2,98E+05
$\lambda = (\Sigma \sigma_i n_i / 2 \times 10^6)^{1/m}$	0,57	0,45	0,80	0,68

Voor ijsgebied A is de toelaatbare spanningswisseling bij 1,0 EDS en 125.000 wisselingen dus 1/0,57 (175%) van de toelaatbare spanningswisseling bij een aantal wisselingen van  $2,0 \times 10^6$ . Er kan ook worden gesteld dat als de spanningswisselingen van 1,0 EDS 363.000 maal voorkomen, dezelfde schade wordt behaald als de vier niveaus afzonderlijk. Deze aanpak is gehanteerd.

- In de berekening van de mast wordt telkens één afspanpunt van de geleiders belast met een trekkracht in lijnrichting van 1,0 EDS.
- Het aantal wisselingen dat deze trekkracht voorkomt wordt vergroot om het hele spectrum te vervangen, dit is afhankelijk van ijsgebied en m-factor.
- Voor iedere staaf in de constructie wordt de schade berekend als gevolg van de trekkracht voor elke geleider.
- De schade wordt gesommeerd over alle geleiders.
- De toetsing is uitgedrukt als de verhouding tussen de optredende spanningswisseling bij  $n = 2 \times 10^6$  wisselingen en de toelaatbare spanningswisseling (43 MPa voor het staalprofiel en 87 MPa voor de bout).

### Resultaten

In de tabellen zijn de resultaten van mast HA+6/c gegeven. Vanwege de exponentiële invloed van het spanningsniveau heeft de verdeling van de U.C.'s een grote variatie. Het meest zwaar belast zijn de diagonalen in het ondervlak van de traverse in de nabijheid van de afspanpunten en de randen van de traverse. De conclusie is dat de staven en bouten voldoen.





**Check galloping**

Datum: 16-6-2021  
 Auteur: TBR  
 Versie: 1.0

RLI-TBG  
 HA/c

Group	Omschrijving	Profiel	Aantal bouten	Bout	Controle netto oppervlak profiel					Controle boutdoorsnede							
					ΔF;o [kN]	Brutto [mm2]	Netto [mm2]	Δσ;i;o [Mpa]	DC;o [Mpa]	Δσ;c;o [Mpa]	opp. [kN]	ΔF;i;b [mm2]	Bout [mm2]	Δσ;i;b [Mpa]	DC;b [Mpa]	Δσ;c;b [Mpa]	UC bout
100	Main leg	80x80x8	2	M20	14.1	1230	1054	13.4	50	43	0.31	21.5	314	34.2	100	87	0.39
101	Main leg	130x130x12	4	M24	22.7	3000	2688	8.5	50	43	0.19	34.3	452	19.0	100	87	0.22
102	Main leg	160x160x15	6	M24	39.1	4671	4281	9.1	50	43	0.21	56.7	452	20.9	100	87	0.24
103	Main leg	160x160x15	8	M24	57.9	4671	4281	13.5	50	43	0.31	85.7	452	23.7	100	87	0.27
104	Main leg	160x160x15	8	M24	73.3	4671	4281	17.1	50	43	0.39	103.9	452	28.7	100	87	0.33
105	Main leg	200x200x24	8	M24	104.0	9060	8436	12.3	50	43	0.28	151.8	452	42.0	100	87	0.48
106	Main leg	200x200x24	0		127.9	9060	9060	14.1	50	43	0.32	185.6	0	0.0	100	87	0.00
107	Main leg	200x200x24	12	M24	136.4	9060	8436	16.2	50	43	0.37	193.6	452	35.7	100	87	0.41
108	Main leg	200x200x24	20	M24	163.2	9060	8436	19.3	50	43	0.44	227.7	452	25.2	100	87	0.29
109	Main leg	200x200x24	20	M24	177.9	9060	8436	21.1	50	43	0.48	246.7	452	27.3	100	87	0.31
110	Main leg	250x250x24	24	M24	195.0	11492	10868	17.9	50	43	0.41	268.3	452	24.7	100	87	0.28
111	Main leg	250x250x24	24	M24	204.8	11492	10868	18.8	50	43	0.43	278.5	452	25.7	100	87	0.30
112.3	Main leg	250x250x24	24	M24	221.5	11492	10868	20.4	50	43	0.47	299.5	452	27.6	100	87	0.32
113.3	Main leg	250x250x20	0		178.0	9700	9700	18.4	50	43	0.42	234.0	0	0.0	100	87	0.00
114.3	Main leg	250x250x24	24	M24	177.7	11492	10868	16.4	50	43	0.38	233.6	452	21.5	100	87	0.25
200	Diag front face	100x100x10	2	M24	17.3	1920	1660	10.4	50	43	0.24	26.4	452	29.2	100	87	0.34
201	Diag front face	150x150x14	6	M24	101.5	4014	3650	27.8	50	43	0.64	153.2	452	56.5	100	87	0.65
202	Diag front face	150x150x14	5	M24	84.9	4014	3650	23.3	50	43	0.54	128.1	452	56.7	100	87	0.65
203	Diag front face	150x150x14	5	M24	74.7	4014	3650	20.5	50	43	0.47	112.7	452	49.9	100	87	0.57
204	Diag front face	120x120x12(12,0,33)	4	M24	101.0	5500	5188	19.5	50	43	0.45	144.0	452	79.7	100	87	0.92
205	Diag front face	120x120x12(12,0,33)	4	M24	87.8	5500	5188	16.9	50	43	0.39	125.4	452	69.3	100	87	0.80
206	Diag front face	120x120x12(12,0,33)	4	M24	80.5	5500	5188	15.5	50	43	0.36	112.2	452	62.1	100	87	0.71
207	Diag front face	120x120x12(12,0,33)	4	M24	74.1	5500	5188	14.3	50	43	0.33	98.1	452	54.2	100	87	0.62
208	Diag front face	120x120x12(12,0,33)	3	M24	66.0	5500	5188	12.7	50	43	0.29	87.4	452	64.4	100	87	0.74
209	Diag front face	120x120x12(12,0,33)	3	M24	62.1	5500	5188	12.0	50	43	0.28	82.0	452	60.5	100	87	0.70
210	Diag front face	120x120x12(12,0,33)	3	M24	61.3	5500	5188	11.8	50	43	0.27	80.8	452	59.6	100	87	0.69
211.3	Diag front face	150x150x15(15,0,33)	3	M24	41.7	6970	6658	6.3	50	43	0.14	55.5	452	40.9	100	87	0.47
212.3	Diag front face	130x130x12(15,0,33)	3	M24	31.0	6040	5728	5.4	50	43	0.12	41.2	452	30.4	100	87	0.35
213.3	Diag front face	160x160x15(14,0,33)	5	M24	32.9	9342	8952	3.7	50	43	0.08	43.8	452	19.4	100	87	0.22
214.3	Diag front face	150x150x12(12,0,33)	4	M24	58.9	6970	6658	8.8	50	43	0.20	78.3	452	43.3	100	87	0.50
300	Diag side face	80x80x8	2	M24	13.9	1230	1022	13.6	50	43	0.31	21.2	452	23.4	100	87	0.27
301	Diag side face	150x150x14	6	M24	107.1	4014	3650	29.3	50	43	0.67	161.8	452	59.7	100	87	0.69
302	Diag side face	150x150x14	5	M24	89.9	4014	3650	24.0	50	43	0.57	135.8	452	60.1	100	87	0.69
303	Diag side face	150x150x14	4	M24	72.9	4014	3650	20.0	50	43	0.46	110.2	452	60.9	100	87	0.70
304	Diag side face	120x120x12(12,0,33)	4	M24	97.8	5500	5188	18.9	50	43	0.43	136.0	452	75.2	100	87	0.86
305	Diag side face	120x120x12(12,0,33)	4	M24	85.6	5500	5188	16.5	50	43	0.38	118.9	452	65.8	100	87	0.76
306	Diag side face	120x120x12(12,0,33)	3	M24	76.5	5500	5188	14.8	50	43	0.34	106.3	452	78.4	100	87	0.90
307	Diag side face	120x120x12(12,0,33)	3	M24	85.7	5500	5188	16.5	50	43	0.38	113.7	452	62.9	100	87	0.72
308	Diag side face	120x120x12(12,0,33)	3	M24	78.4	5500	5188	15.1	50	43	0.35	104.0	452	76.7	100	87	0.88
309	Diag side face	120x120x12(12,0,33)	3	M24	74.0	5500	5188	14.3	50	43	0.33	98.1	452	72.4	100	87	0.83
310	Diag side face	120x120x12(12,0,33)	3	M24	69.3	5500	5188	13.4	50	43	0.31	91.9	452	67.8	100	87	0.78

### Check galloping

Datum: 16-6-2021  
 Auteur: TBR  
 Versie: 1.0

RLI-TBG  
 HA/c

Group	Omschrijving	Profiel	Aantal bouten	Bout	Controle netto oppervlak profiel					Controle boutdoorsnede							
					ΔF;o [kN]	Brutto [mm2]	Netto [mm2]	Δσ;i;0 [Mpa]	DC;o [Mpa]	Δσ;c;o [Mpa]	UC opp.	ΔF;i;b [kN]	Bout [mm2]	Δσ;i;b [Mpa]	DC;b [Mpa]	Δσ;c;b [Mpa]	UC bout
311.3	Diag side face	150x150x12(12,0,0.33)	3	M24	53.8	6970	6658	8.1	50	43	0.19	452	53.1	100	87	0.61	
312.3	Diag side face	130x130x12#(15,0,0.33)	3	M24	39.1	6040	5728	6.8	50	43	0.16	452	38.6	100	87	0.44	
313.3	Diag side face	160x160x15#(14,0,0.33)	5	M24	40.4	9342	8952	4.5	50	43	0.10	452	23.9	100	87	0.28	
314.3	Diag front face	150x150x12(12,0,0.33)	4	M24	74.2	6970	6658	11.1	50	43	0.26	452	54.9	100	87	0.63	
400	Horizontal lower ca.	180x180x16	10	M24	69.2	5540	5124	13.5	50	43	0.31	452	23.3	100	87	0.27	
401	Lower chord lower ca.	150x150x14	10	M24	132.4	4014	3650	36.3	50	43	0.83	452	44.7	100	87	0.51	
402	Lower chord lower ca.	150x150x14	0		117.6	4014	4014	29.3	50	43	0.67	179.5	0	0.0	100	87	0.00
403	Lower chord lower ca.	150x150x14	0		104.5	4014	4014	26.0	50	43	0.60	159.5	0	0.0	100	87	0.00
404	Lower chord lower ca.	150x150x14	0		76.7	4014	4014	19.1	50	43	0.44	117.2	0	0.0	100	87	0.00
405	Lower chord lower ca.	150x150x14	0		47.0	4014	4014	11.7	50	43	0.27	71.8	0	0.0	100	87	0.00
406	Lower chord lower ca.	150x150x14	0		26.3	4014	4014	6.6	50	43	0.15	40.1	0	0.0	100	87	0.00
407	Lower chord lower ca.	150x150x14	0		0.4	4014	4014	0.1	50	43	0.00	0	0.0	100	87	0.00	
410	Horizontal lower ca.	130x130x12	3	M24	19.5	3000	2688	7.3	50	43	0.17	29.5	452	21.7	100	87	0.25
411	Horizontal lower ca.	150x150x14 (not coup)	2	M24	13.3	8028	7664	1.7	50	43	0.04	20.3	452	22.5	100	87	0.26
412	Horizontal lower ca.	HEA140	0		0.6	3140	3140	0.2	50	43	0.00	0	0.0	100	87	0.00	
413	Horizontal lower ca.	150x150x18 (not coup)	2	M24	27.1	10200	9732	2.8	50	43	0.06	41.4	452	45.8	100	87	0.53
414	Beam lower ca.	HEB220	0		1.7	9104	9104	0.2	50	43	0.00	2.7	0	0.0	100	87	0.00
415	Horizontal lower ca.	100x100x10	0		4.6	3740	3740	1.2	50	43	0.03	7.0	0	0.0	100	87	0.00
426	Upper chord lower ca.	100x100x10	4	M24	11.4	1920	1660	6.9	50	43	0.16	17.2	452	9.5	100	87	0.11
427	Upper chord lower ca.	100x100x10	0		10.4	1920	1920	5.4	50	43	0.12	15.7	0	0.0	100	87	0.00
428	Upper chord lower ca.	100x100x10	0		10.8	1920	1920	5.6	50	43	0.13	16.3	0	0.0	100	87	0.00
429	Upper chord lower ca.	100x100x10	0		11.6	1920	1920	6.0	50	43	0.14	17.5	0	0.0	100	87	0.00
430	Upper chord lower ca.	100x100x10	4	M20	11.6	1920	1700	6.8	50	43	0.16	17.5	314	14.0	100	87	0.16
431	Upper chord lower ca.	100x100x10	2	M20	15.5	1920	1700	9.1	50	43	0.21	23.3	314	37.1	100	87	0.43
433	Stability bracing lower ca.	70x70x6	1	M16	0.2	810	702	0.3	50	43	0.01	0.3	201	1.4	100	87	0.02
434	Hand rail	60x60x6	0		0.1	690	690	0.1	50	43	0.00	0.1	0	0.0	100	87	0.00
435	Hand rail	60x60x6	0		0.0	690	690	0.0	50	43	0.00	0	0.0	100	87	0.00	
436	Hand rail	60x60x6	0		0.0	690	690	0.1	50	43	0.00	0.1	0	0.0	100	87	0.00
437	Stability bracing lower ca.	70x70x6	1	M16	0.6	810	702	0.8	50	43	0.02	0.8	201	4.2	100	87	0.05
440	Vertical side face lower ca.	70x70x6	1	M16	1.9	810	702	2.7	50	43	0.06	2.8	201	14.1	100	87	0.16
441	Vertical side face lower ca.	70x70x6	1	M16	2.5	810	702	3.5	50	43	0.08	3.8	201	18.9	100	87	0.22
442	Vertical side face lower ca.	60x60x6	1	M16	3.3	690	582	5.6	50	43	0.13	5.0	201	24.9	100	87	0.29
443	Vertical side face lower ca.	60x60x6	1	M16	0.2	690	582	0.3	50	43	0.01	0.3	201	1.4	100	87	0.02
444	Vertical side face lower ca.	60x60x6	1	M16	9.2	690	582	15.9	50	43	0.36	14.0	201	69.9	100	87	0.80
460	Diag side face lower ca.	80x80x6	2	M16	4.7	940	832	5.6	50	43	0.13	7.0	201	17.4	100	87	0.20
461	Diag side face lower ca.	60x60x6	1	M16	3.1	690	582	5.4	50	43	0.12	4.8	201	23.7	100	87	0.27
462	Diag side face lower ca.	60x60x6	1	M16	5.0	690	582	8.6	50	43	0.20	7.6	201	37.9	100	87	0.44
463	Diag side face lower ca.	60x60x6	1	M16	6.7	690	582	11.5	50	43	0.26	10.2	201	25.4	100	87	0.29
464	Diag side face lower ca.	60x60x6	2	M16	9.3	690	582	16.0	50	43	0.37	14.2	201	35.4	100	87	0.41
465	Stability bracing lower ca.	90x90x9	1	M16	0.3	1539	1377	0.2	50	43	0.00	0.4	201	2.0	100	87	0.02
475	Diag lower plane lower ca.	80x80x6	2	M20	13.8	940	808	17.1	50	43	0.39	19.3	314	30.7	100	87	0.35

### Check galloping

Datum: 16-6-2021  
 Auteur: TBR  
 Versie: 1.0

RLI-TBG  
 HA/c

Group	Omschrijving	Profiel	Aantal bouten	Bout	Controle netto oppervlak profiel										Controle boutdoorsnede									
					ΔF;o [kN]	Brutto [mm2]	Netto [mm2]	Δσ;i;o [Mpa]	DC;o [Mpa]	Δσ;c;o [Mpa]	opp.	UC	ΔF;i;b [kN]	Bout [mm2]	Opp.	Δσ;i;b [Mpa]	DC;b [Mpa]	Δσ;c;b [Mpa]	bout	UC				
476	Diag lower plane lower ca.	80x80x6	2	M20	16.2	940	808	20.0	50	43	0.46	314	35.8	100	87	0.41								
477	Diag lower plane lower ca.	80x80x6	2	M20	11.4	940	808	14.1	50	43	0.32	314	27.0	100	87	0.31								
478	Diag lower plane lower ca.	80x80x6	2	M20	14.1	940	808	17.5	50	43	0.40	314	34.4	100	87	0.40								
479	Diag lower plane lower ca.	70x70x6	2	M16	15.6	810	702	22.2	50	43	0.51	201	59.1	100	87	0.68								
480	Diag lower plane lower ca.	70x70x6	2	M20	17.5	810	678	25.8	50	43	0.59	314	42.5	100	87	0.49								
481	Diag lower plane lower ca.	70x70x6	2	M20	20.1	810	678	29.6	50	43	0.68	314	48.8	100	87	0.56								
482	Diag lower plane lower ca.	70x70x6	2	M20	23.5	810	678	34.6	50	43	0.80	358	57.0	100	87	0.66								
483	Diag lower plane lower ca.	70x70x6	2	M20	26.1	810	678	38.5	50	43	0.88	398	63.4	100	87	0.73								
484	Diag lower plane lower ca.	70x70x6	2	M16	12.1	810	702	17.2	50	43	0.40	185	46.0	100	87	0.53								
485	Plan bracing lower ca.	120x120x10	3	M24	25.1	2320	2060	12.2	50	43	0.28	37.7	452	27.8	100	87	0.32							
486	Plan bracing lower ca.	120x120x10	4	M24	0.0	2320	2060	0.0	50	43	0.00	0.1	452	0.0	100	87	0.00							
500	Horizontal mid ca.	200x200x18	10	M24	121.8	6910	6442	18.9	50	43	0.43	185.0	452	40.9	100	87	0.47							
501	Lower chord mid ca.	180x180x18	10	M24	206.0	6190	5722	36.0	50	43	0.83	312.9	452	69.2	100	87	0.80							
502	Lower chord mid ca.	180x180x18	0	0	199.3	6190	6190	32.2	50	43	0.74	303.1	0	0.0	100	87	0.00							
503	Lower chord mid ca.	180x180x18	0	0	181.8	6190	6190	29.4	50	43	0.68	277.3	0	0.0	100	87	0.00							
504	Lower chord mid ca.	180x180x18	8	M24	159.7	6190	5722	27.9	50	43	0.64	243.8	452	67.4	100	87	0.78							
505	Lower chord mid ca.	160x160x15	8	M24	136.5	4671	4281	31.9	50	43	0.73	208.4	452	57.6	100	87	0.66							
506	Lower chord mid ca.	160x160x15	0	0	97.7	4671	4671	20.9	50	43	0.48	149.2	0	0.0	100	87	0.00							
507	Lower chord mid ca.	160x160x15	0	0	62.8	4671	4671	13.4	50	43	0.31	95.9	0	0.0	100	87	0.00							
508	Lower chord mid ca.	160x160x15	0	0	31.2	4671	4671	6.7	50	43	0.15	47.5	0	0.0	100	87	0.00							
509	Lower chord mid ca.	160x160x15	2	M20	0.3	4671	4341	0.1	50	43	0.00	0.4	314	0.7	100	87	0.01							
511	Horizontal mid ca.	150x150x12	3	M24	36.7	3480	3168	11.6	50	43	0.27	55.9	452	41.2	100	87	0.47							
512	Beam mid ca.	150x150x14 (not coup	2	M24	16.1	8028	7664	2.1	50	43	0.05	22.4	452	24.8	100	87	0.29							
513	Horizontal mid ca.	HEA140	0	0	0.2	3140	3140	0.1	50	43	0.00	0.3	0	0.0	100	87	0.00							
514	Beam mid ca.	150x150x18 (not coup	2	M24	25.9	10200	9732	2.7	50	43	0.06	39.6	452	43.8	100	87	0.50							
515	Horizontal mid ca.	HEB220	0	0	2.3	9104	9104	0.3	50	43	0.01	3.6	0	0.0	100	87	0.00							
516	Beam mid ca.	UNP220	0	0	7.0	3740	3740	1.9	50	43	0.04	10.7	0	0.0	100	87	0.00							
526	Upper chord mid ca.	120x120x12	4	M24	28.5	2750	2438	11.7	50	43	0.27	43.1	452	23.8	100	87	0.27							
527	Upper chord mid ca.	120x120x12	0	0	28.7	2750	2750	10.4	50	43	0.24	43.5	0	0.0	100	87	0.00							
528	Upper chord mid ca.	120x120x12	6	M24	27.5	2750	2438	11.3	50	43	0.26	41.8	452	15.4	100	87	0.18							
529	Upper chord mid ca.	100x100x10	6	M24	25.4	1920	1660	15.3	50	43	0.35	38.7	452	14.3	100	87	0.16							
530	Upper chord mid ca.	100x100x10	0	0	24.0	1920	1920	12.5	50	43	0.29	36.5	0	0.0	100	87	0.00							
531	Upper chord mid ca.	100x100x10	0	0	22.5	1920	1920	11.7	50	43	0.27	34.2	0	0.0	100	87	0.00							
532	Upper chord mid ca.	100x100x10	4	M24	22.5	1920	1660	13.6	50	43	0.31	34.2	452	18.9	100	87	0.22							
533	Upper chord mid ca.	100x100x10	2	M24	25.5	1920	1660	15.3	50	43	0.35	38.7	452	42.8	100	87	0.49							
535	Stability bracing mid ca.	70x70x6	1	M16	0.4	810	702	0.6	50	43	0.01	0.6	201	2.9	100	87	0.03							
536	Hand rail	60x60x6	0	0	0.1	690	690	0.1	50	43	0.00	0.1	0	0.0	100	87	0.00							
537	Hand rail	60x60x6	0	0	0.0	690	690	0.0	50	43	0.00	0.0	0	0.0	100	87	0.00							
538	Hand rail	60x60x6	0	0	0.0	690	690	0.0	50	43	0.00	0.0	0	0.0	100	87	0.00							
539	Stability bracing mid ca.	70x70x6	1	M16	1.2	810	702	1.7	50	43	0.04	1.6	201	8.2	100	87	0.09							
540	Vertical side face mid ca.	80x80x6	1	M16	2.7	940	832	3.3	50	43	0.08	3.8	201	19.2	100	87	0.22							



**Check galloping**

Datum: 16-6-2021  
 Auteur: TBR  
 Versie: 1.0

RLI-TBG  
 HA/c

Group	Omschrijving	Profiel	Aantal bouten	Bout	Controle netto oppervlak profiel										Controle boutdoorsnede									
					$\Delta F_o$ [kN]	Brutto [mm <sup>2</sup> ]	Netto [mm <sup>2</sup> ]	$\Delta\sigma_o$ [Mpa]	DC <sub>o</sub> [Mpa]	$\Delta\sigma_c$ [Mpa]	UC opp.	$\Delta F_o$ [kN]	Bout [mm <sup>2</sup> ]	$\Delta\sigma_b$ [Mpa]	DC <sub>b</sub> [Mpa]	$\Delta\sigma_c$ [Mpa]	UC bout							
541	Vertical side face mid ca.	80x80x6	1	M16	2.7	940	832	3.2	50	43	0.07	3.9	201	19.6	100	87	0.22							
542	Vertical side face mid ca.	60x60x6	1	M16	1.4	690	582	2.5	50	43	0.06	2.2	201	10.9	100	87	0.12							
543	Vertical side face mid ca.	60x60x6	1	M16	2.1	690	582	3.6	50	43	0.08	3.2	201	15.9	100	87	0.18							
544	Vertical side face mid ca.	60x60x6	1	M16	2.5	690	582	4.3	50	43	0.10	3.8	201	18.9	100	87	0.22							
545	Vertical side face mid ca.	60x60x6	1	M16	0.3	690	582	0.6	50	43	0.01	0.5	201	2.5	100	87	0.03							
546	Vertical side face mid ca.	60x60x6	2	M16	11.1	690	582	19.1	50	43	0.44	17.0	201	42.2	100	87	0.49							
560	Diag side face mid ca.	80x80x6	2	M16	2.4	940	832	2.9	50	43	0.07	3.7	201	9.1	100	87	0.10							
561	Diag side face mid ca.	70x70x6	2	M16	4.1	810	702	5.9	50	43	0.14	5.8	201	14.5	100	87	0.17							
562	Diag side face mid ca.	60x60x6	2	M16	4.3	690	582	7.3	50	43	0.17	6.2	201	15.5	100	87	0.18							
563	Diag side face mid ca.	60x60x6	1	M16	2.5	690	582	4.3	50	43	0.10	3.8	201	19.0	100	87	0.22							
564	Diag side face mid ca.	60x60x6	2	M16	4.4	690	582	7.6	50	43	0.17	6.7	201	16.8	100	87	0.19							
565	Diag side face mid ca.	60x60x6	2	M16	5.2	690	582	9.0	50	43	0.21	8.0	201	19.9	100	87	0.23							
566	Diag side face mid ca.	60x60x6	2	M16	6.4	690	582	10.9	50	43	0.25	9.7	201	24.1	100	87	0.28							
567	Stability bracing mid ca.	70x70x6	1	M16	0.7	810	702	0.9	50	43	0.02	0.9	201	4.4	100	87	0.05							
575	Diag lower plane mid ca.	70x70x6	2	M20	11.0	810	678	16.2	50	43	0.37	15.3	314	24.4	100	87	0.28							
576	Diag lower plane mid ca.	70x70x6	2	M20	13.6	810	678	20.0	50	43	0.46	18.9	314	30.1	100	87	0.35							
577	Diag lower plane mid ca.	70x70x6	2	M20	14.2	810	678	21.0	50	43	0.48	19.9	314	31.6	100	87	0.36							
578	Diag lower plane mid ca.	70x70x6	2	M20	15.6	810	678	23.0	50	43	0.53	21.8	314	34.8	100	87	0.41							
579	Diag lower plane mid ca.	70x70x6	2	M20	16.0	810	678	23.5	50	43	0.54	22.3	314	35.4	100	87	0.35							
580	Diag lower plane mid ca.	70x70x6	2	M20	12.9	810	678	19.0	50	43	0.44	19.3	314	30.7	100	87	0.44							
581	Diag lower plane mid ca.	70x70x6	2	M20	15.7	810	678	23.1	50	43	0.53	23.9	314	38.1	100	87	0.47							
582	Diag lower plane mid ca.	70x70x6	2	M20	16.8	810	678	24.7	50	43	0.57	25.6	314	40.8	100	87	0.53							
583	Diag lower plane mid ca.	70x70x6	2	M20	19.1	810	678	28.2	50	43	0.65	29.2	314	46.5	100	87	0.61							
584	Diag lower plane mid ca.	70x70x6	2	M20	21.7	810	678	32.0	50	43	0.74	33.1	314	52.7	100	87	0.74							
585	Diag lower plane mid ca.	80x80x6	2	M20	26.4	940	808	32.6	50	43	0.75	40.2	314	64.1	100	87	0.82							
586	Diag lower plane mid ca.	80x80x6	2	M20	29.2	940	808	36.2	50	43	0.83	44.6	314	71.0	100	87	0.82							
587	Diag lower plane mid ca.	60x60x6	2	M16	11.6	690	582	19.9	50	43	0.46	17.7	201	44.0	100	87	0.51							
588	Plan bracing mid ca.	140x140x13	5	M24	88.8	3521	3183	27.9	50	43	0.64	135.1	452	59.8	100	87	0.69							
589	Plan bracing mid ca.	150x150x12	4	M24	57.0	3480	3168	18.0	50	43	0.41	86.7	452	48.0	100	87	0.55							
600	Horizontal top ca.	200x200x18	10	M24	132.2	6910	6442	20.5	50	43	0.47	199.8	452	44.2	100	87	0.51							
601	Lower chord top ca.	180x180x18	8	M24	172.3	6190	5722	30.1	50	43	0.69	262.8	452	72.7	100	87	0.84							
602	Lower chord top ca.	180x180x18	6	M24	142.9	6190	5722	25.0	50	43	0.57	218.1	452	80.4	100	87	0.92							
603	Lower chord top ca.	150x150x14	6	M24	106.2	4014	3650	29.1	50	43	0.67	162.1	452	59.8	100	87	0.69							
604	Lower chord top ca.	150x150x14	0		50.0	4014	4014	12.5	50	43	0.29	76.3	0	0.0	100	87	0.00							
605	Lower chord top ca.	150x150x14	2	M20	23.6	4014	3706	6.4	50	43	0.15	35.7	314	56.8	100	87	0.65							
606	Lower chord top ca.	150x150x14	2	M20	4.6	4014	3706	1.2	50	43	0.03	6.6	314	10.5	100	87	0.12							
608	Earth peak lower chord	80x80x8	2	M20	6.2	1230	1054	5.9	50	43	0.13	8.9	314	14.1	100	87	0.16							
609	Earth peak lower chord	80x80x8	2	M20	5.3	1230	1054	5.0	50	43	0.11	7.4	314	11.8	100	87	0.14							
610	Horizontal top ca.	130x130x12	3	M24	38.6	3000	2688	14.3	50	43	0.33	57.7	452	42.5	100	87	0.49							
611	Horizontal top ca.	150x150x14 (not coup	2	M24	13.5	8028	7664	1.8	50	43	0.04	20.7	452	22.9	100	87	0.26							
612	Horizontal top ca.	HEA140	0		0.7	3140	3140	0.2	50	43	0.00	0.9	0	0.0	100	87	0.00							



**Check galloping**

Datum: 16-6-2021  
 Auteur: TBR  
 Versie: 1.0

RLI-TBG  
 HA/c

Group	Omschrijving	Profiel	Aantal bouten	Bout	Controle netto oppervlak profiel					Controle boutdoorsnede							
					ΔF;o [kN]	Brutto [mm2]	Netto [mm2]	Δσ;i;o [Mpa]	DC;o [Mpa]	Δσ;c;o [Mpa]	UC opp.	ΔF;i;b [kN]	Bout [mm2]	Δσ;i;b [Mpa]	DC;b [Mpa]	Δσ;c;b [Mpa]	UC bout
613	Horizontaal top ca.	150x150x18 (not coup)		2	26.6	10200	9732	2.7	50	43	0.06	40.6	452	44.9	100	87	0.52
614	Beam top ca.	HEB220		0	1.8	9104	9104	0.2	50	43	0.00	2.8	0	0.0	100	87	0.00
615	Earth peak horizontal	60x60x6		1	0.8	690	582	1.4	50	43	0.03	1.2	201	5.8	100	87	0.07
616	Earth peak horizontal	60x60x6		1	0.8	690	582	1.4	50	43	0.03	1.2	201	5.9	100	87	0.07
617	Earth peak horizontal	60x60x6		1	0.0	690	582	0.0	50	43	0.00	0.0	201	0.1	100	87	0.00
618	Beam top ca.	UNP220		0	4.5	3740	3740	1.2	50	43	0.03	6.8	0	0.0	100	87	0.00
626	Upper chord top ca.	120x120x12		4	36.9	2750	2438	15.2	50	43	0.35	56.3	452	31.2	100	87	0.36
627	Upper chord top ca.	100x100x10		3	15.1	1920	1660	9.1	50	43	0.21	22.8	452	16.8	100	87	0.19
628	Upper chord top ca.	100x100x10		6	14.5	1920	1660	8.8	50	43	0.20	22.1	452	8.1	100	87	0.09
629	Upper chord top ca.	100x100x10		3	14.8	1920	1660	8.9	50	43	0.21	22.6	452	16.7	100	87	0.19
630	Earth peak upper chord	130x130x12		0	53.7	3000	3000	17.9	50	43	0.41	73.4	0	0.0	100	87	0.00
631	Earth peak upper chord	130x130x12		4	47.0	3000	2688	17.5	50	43	0.40	66.0	452	36.5	100	87	0.42
632	Earth peak upper chord	120x120x10		4	44.5	2320	2060	21.6	50	43	0.50	62.5	452	34.5	100	87	0.40
633	Earth peak upper chord	120x120x10		0	38.6	2320	2320	16.6	50	43	0.38	54.2	0	0.0	100	87	0.00
634	Earth peak upper chord	120x120x10		0	30.0	2320	2320	12.9	50	43	0.30	42.1	0	0.0	100	87	0.00
635	Earth peak upper chord	120x120x10		2	16.1	2320	2100	7.7	50	43	0.18	22.6	314	35.9	100	87	0.41
637	Stability bracing top ca.	70x70x7		1	8.9	940	814	10.9	50	43	0.25	13.4	201	66.6	100	87	0.77
638	Earth peak horizontal	UNP160		2	4.7	2400	2235	2.1	50	43	0.05	6.6	314	10.5	100	87	0.12
640	Vertical side face top ca.	60x60x6		2	3.5	690	582	6.0	50	43	0.14	5.0	201	12.4	100	87	0.14
641	Vertical side face top ca.	60x60x6		2	13.3	690	582	22.9	50	43	0.53	20.1	201	50.0	100	87	0.57
642	Vertical side face top ca.	80x80x6		1	2.9	940	832	3.5	50	43	0.08	4.3	201	21.4	100	87	0.25
643	Vertical side face top ca.	80x80x6		1	0.2	940	832	0.3	50	43	0.01	0.3	201	1.7	100	87	0.02
644	Vertical side face top ca.	80x80x6		1	6.2	940	832	7.5	50	43	0.17	9.5	201	47.4	100	87	0.55
645	Vertical side face top ca.	80x80x8		1	0.1	1230	1086	0.1	50	43	0.00	0.2	201	0.8	100	87	0.01
646	Earth peak vertical side face	60x60x6		1	0.2	690	582	0.4	50	43	0.01	0.3	201	1.5	100	87	0.02
660	Diag side face top ca.	70x70x6		2	5.0	810	702	7.1	50	43	0.16	6.9	201	17.1	100	87	0.20
661	Diag side face top ca.	80x80x8		2	4.9	1230	1086	4.5	50	43	0.10	7.3	201	18.1	100	87	0.21
662	Diag side face top ca.	70x70x6		2	6.1	810	702	8.7	50	43	0.20	9.1	201	22.7	100	87	0.26
663	Earth peak diag side face	80x80x6		1	0.2	940	832	0.2	50	43	0.00	0.2	201	1.2	100	87	0.01
664	Stability bracing top ca.	80x80x8		2	16.8	1230	1086	15.5	50	43	0.36	25.4	201	63.1	100	87	0.73
673	Earth peak diag upper side	60x60x6		2	7.5	690	582	12.9	50	43	0.30	10.5	201	26.2	100	87	0.30
674	Earth peak diag upper side	60x60x6		2	5.8	690	582	10.0	50	43	0.23	8.2	201	20.3	100	87	0.23
675	Diag lower plane top ca.	70x70x6		2	13.3	810	678	19.6	50	43	0.45	18.5	314	29.5	100	87	0.34
676	Diag lower plane top ca.	70x70x6		2	17.0	810	678	25.0	50	43	0.58	23.8	314	37.9	100	87	0.44
677	Diag lower plane top ca.	70x70x6		2	15.4	810	678	22.8	50	43	0.52	21.6	314	34.4	100	87	0.40
678	Diag lower plane top ca.	70x70x6		2	13.1	810	678	19.4	50	43	0.45	19.9	314	31.7	100	87	0.36
679	Diag lower plane top ca.	70x70x6		2	15.9	810	678	22.3	50	43	0.51	23.0	314	36.7	100	87	0.42
680	Diag lower plane top ca.	70x70x6		2	16.7	810	678	24.6	50	43	0.57	25.4	314	40.4	100	87	0.47
681	Diag lower plane top ca.	70x70x6		2	25.8	810	678	38.0	50	43	0.87	39.3	314	62.6	100	87	0.72
682	Diag lower plane top ca.	70x70x6		2	27.9	810	678	41.2	50	43	0.95	42.7	314	67.9	100	87	0.78
683	Diag lower plane top ca.	80x80x6		2	29.7	940	808	36.8	50	43	0.85	45.4	314	72.3	100	87	0.83



## Check galloping

Datum: 16-6-2021  
 Auteur: TBR  
 Versie: 1.0

RLI-TBG  
 HA/c

Group	Omschrijving	Profiel	Aantal bouten	Bout	Controle netto oppervlak profiel					Controle boutdoorsnede							
					$\Delta F_o$ [kN]	Brutto [mm <sup>2</sup> ]	Netto [mm <sup>2</sup> ]	$\Delta \sigma_{jo}$ [Mpa]	DC <sub>jo</sub> [Mpa]	$\Delta \sigma_{co}$ [Mpa]	UC opp. [kN]	$\Delta F_{f;b}$ [kN]	Opp. Bout [mm <sup>2</sup> ]	$\Delta \sigma_{j;b}$ [Mpa]	DC <sub>b</sub> [Mpa]	$\Delta \sigma_{c;b}$ [Mpa]	UC bout
684	Diag lower plane top ca.	80x80x6		2	29.4	940	808	36.3	50	43	0.84	44.8	314	71.4	100	87	0.82
685	Diag lower plane top ca.	60x60x6		2	11.3	690	582	19.4	50	43	0.45	17.3	201	42.9	100	87	0.49
686	Earth peak diag lower plane	70x70x7		1	0.4	940	814	0.5	50	43	0.01	0.6	201	2.8	100	87	0.03
687	Earth peak diag lower plane	70x70x7		1	2.3	940	814	2.8	50	43	0.06	3.4	201	16.9	100	87	0.19
688	Earth peak diag upper plane	70x70x6		2	8.3	810	702	11.8	50	43	0.27	12.3	201	30.7	100	87	0.35
689	Earth peak diag upper plane	70x70x6		2	9.1	810	702	13.0	50	43	0.30	13.6	201	33.9	100	87	0.39
690	Earth peak diag upper plane	60x60x6		2	9.8	690	582	16.8	50	43	0.39	14.6	201	36.3	100	87	0.42
691	Earth peak diag upper plane	60x60x6		2	10.7	690	582	18.3	50	43	0.42	15.9	201	39.6	100	87	0.46
692	Earth peak diag upper plane	60x60x6		1	2.3	690	582	3.9	50	43	0.09	3.2	201	16.1	100	87	0.18
693	Earth peak diag upper plane	60x60x6		1	2.5	690	582	4.4	50	43	0.10	3.6	201	17.7	100	87	0.20
694	Earth peak diag upper plane	60x60x6		1	2.8	690	582	4.8	50	43	0.11	3.9	201	19.6	100	87	0.22
695	Earth peak diag upper plane	60x60x6		1	3.2	690	582	5.5	50	43	0.13	4.5	201	22.2	100	87	0.26
696	Earth peak diag upper plane	60x60x6		1	3.8	690	582	6.5	50	43	0.15	5.3	201	26.6	100	87	0.31
697	Earth peak diag upper plane	60x60x6		1	4.6	690	582	7.9	50	43	0.18	6.4	201	32.1	100	87	0.37
698	Plan bracing top ca.	150x150x12		4	56.4	3480	3168	17.8	50	43	0.41	84.7	452	46.9	100	87	0.54
699	Plan bracing top ca.	140x140x13		5	92.5	3521	3183	29.1	50	43	0.67	138.7	452	61.4	100	87	0.71
700.3	Hor. Plan bracing hip structur	120x120x10		2	1.2	2320	2100	0.6	50	43	0.01	1.6	314	2.5	100	87	0.03
701.3	Hor. Plan bracing hip structur	110x110x10		2	0.3	2112	1892	0.2	50	43	0.00	0.4	314	0.7	100	87	0.01
702.3	Hor. Plan bracing hip structur	120x120x10 (not coup		2	0.0	4640	4420	0.0	50	43	0.00	0.0	314	0.0	100	87	0.00
703.2	2nd plan bacing	130x130x12#(15,0,33		3	61.7	6040	5728	10.8	50	43	0.25	80.8	452	59.6	100	87	0.69
704	2nd plan bacing	90x90x8		2	2.7	1390	1214	2.2	50	43	0.05	3.9	314	6.3	100	87	0.07
705	2nd plan bacing	90x90x8 (not coupled)		2	0.0	2780	2604	0.0	50	43	0.00	0.0	314	0.0	100	87	0.00
710	Horizontal top of lower ca.	120x120x10		4	12.0	2320	2060	5.8	50	43	0.13	16.6	452	9.2	100	87	0.11
711	Horizontal top of lower ca.	120x120x10		2	1.1	2320	2060	0.5	50	43	0.01	1.5	452	1.7	100	87	0.02
712	Horizontal top of mid ca.	120x120x10		4	12.1	2320	2060	5.9	50	43	0.14	17.0	452	9.4	100	87	0.11
713	Horizontal top of mid ca.	110x110x10		2	1.3	2112	1852	0.7	50	43	0.02	1.6	452	1.8	100	87	0.02
714	Horizontal top of top ca.	120x120x12		4	17.6	2750	2438	7.2	50	43	0.17	26.8	452	14.8	100	87	0.17
715	Horizontal top of top ca.	100x100x10		2	0.8	1920	1660	0.5	50	43	0.01	1.2	452	1.4	100	87	0.02



## **About DNV**

DNV is the independent expert in risk management and assurance, operating in more than 100 countries. Through its broad experience and deep expertise DNV advances safety and sustainable performance, sets industry benchmarks, and inspires and invents solutions.

Whether assessing a new ship design, optimizing the performance of a wind farm, analyzing sensor data from a gas pipeline or certifying a food company's supply chain, DNV enables its customers and their stakeholders to make critical decisions with confidence.

Driven by its purpose, to safeguard life, property, and the environment, DNV helps tackle the challenges and global transformations facing its customers and the world today and is a trusted voice for many of the world's most successful and forward-thinking companies.